

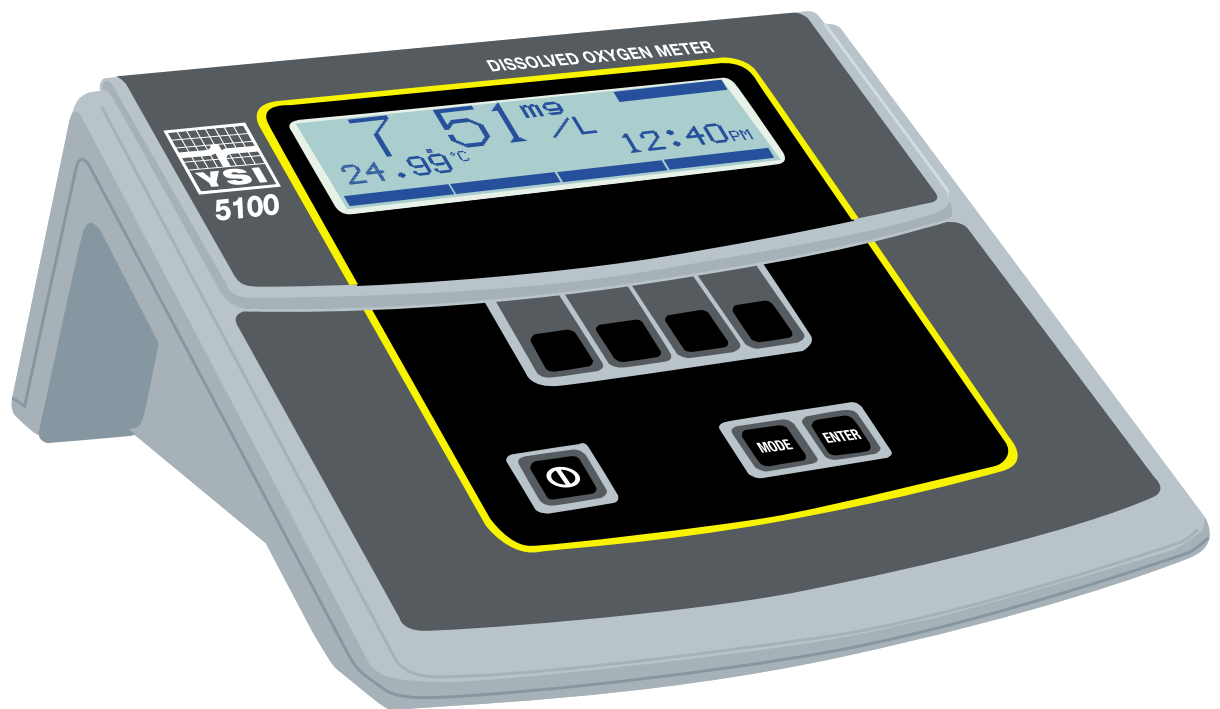

*YSI incorporated*



**YSI Model 5000**

**YSI Model 5100**

**Dissolved Oxygen  
Temperature**

**Operations Manual**

# Table of Contents

---

<b>1. General Description .....</b>	<b>1</b>
<b>2. Specifications .....</b>	<b>3</b>
<b>3. Quick Start .....</b>	<b>5</b>
<b>4. Controls .....</b>	<b>6</b>
4.1 Front Panel.....	6
4.2 Software Flow Chart.....	7
4.3 Rear Panel.....	9
<b>5. Setup .....</b>	<b>11</b>
5.1 Display Setup.....	12
5.2 Report Setup .....	14
5.3 Autostable Setup.....	16
5.4 System Setup .....	17
<b>6. Calibration .....</b>	<b>19</b>
6.1 Dissolved Oxygen Calibration.....	19
Auto Cal.....	20
DO Cal (manual) .....	21
Barometer .....	22
Salinity.....	23
6.2 Zero Calibration.....	24
<b>7. Operation .....</b>	<b>26</b>
7.1 Main Mode .....	26
Making Measurements.....	26
Store.....	27
Review .....	28
Send .....	30
7.2 Application Mode .....	32
OUR.....	32
SOUR.....	37
Remote.....	42
<b>8. Diagnostics.....</b>	<b>44</b>
History .....	44
Sensor .....	45
Reset Ps.....	46
<b>9. Principles of Operation.....</b>	<b>47</b>
<b>10. Understanding Dissolved Oxygen Error Factors .....</b>	<b>48</b>

<b>11.</b>	<b>Maintenance</b> .....	<b>51</b>
	Batteries .....	51
<b>12.</b>	<b>Troubleshooting</b> .....	<b>53</b>
	Error Messages .....	53
<b>13.</b>	<b>Warranty &amp; Repair</b> .....	<b>55</b>
	Cleaning Instructions .....	56
	Packing Instructions .....	57
<b>14.</b>	<b>Required Notice</b> .....	<b>58</b>
<b>15.</b>	<b>Accessories and Replacement Parts</b> .....	<b>59</b>
<b>16.</b>	<b>Appendix A - Oxygen Solubility Table</b> .....	<b>60</b>
<b>17.</b>	<b>Appendix B - Pressures and Altitudes</b> .....	<b>62</b>
<b>18.</b>	<b>Appendix C - Conversion Factors</b> .....	<b>63</b>
<b>19.</b>	<b>Appendix D - Remote Command Language</b> .....	<b>64</b>

# 1. General Description

---

## *Model 5000 Features*

The Model 5000 is a microprocessor based, menu-driven, dissolved oxygen meter designed to perform laboratory measurement of dissolved oxygen and Biochemical Oxygen Demand (BOD). The instrument's menu system makes it simple to use.

The Model 5000 has a new case design which facilitates laboratory measurement. The angled profile makes these instruments both functional and attractive. A large graphical display provides on-screen menus, and large data fields for ease of operation and readability. The angle and position of the keypad make operation of the 5000 comfortable. The tactile and audio response from each key stroke give you the confidence that every command has been received.

The Model 5000 is compatible with all existing YSI dissolved oxygen probes when used with the YSI Model 5011 adapter. The new YSI Model 5010 self-stirring BOD Probe allows you to operate the probe from the instrument's power supply, eliminating the need for a separate power cable for the probe.

Internal memory for storing up to 100 sets of data, and an RS232 port allow you to upload data from the Model 5000 directly to your computer. Or you can use your Model 5000 with YSI *BOD Analyst* software.

## **Model 5000 Features & Benefits**

<b>Feature</b>	<b>Benefit</b>
1. Menu driven operation for ease of use	Ease of use -- little need for instruction manual.
2. Compatible with all existing YSI probes	No need to re-invest in probes. (5011 adapter required)
3. Large graphic liquid crystal display	Easy to read.
4. Internal memory for 100 data points	No need to write down readings.
5. Auto stabilization feature	You are alerted when stable DO reading is reached.
6. Compatible with YSI <i>BOD Analyst</i> Software	Software does all the BOD calculations -- no chance for math errors.
7. User upgradable internal software	No fear that an instrument purchased today will be out of date tomorrow.
8. RS232 interface	Computer uploads to spreadsheets eliminates transcription errors, & increases regulatory confidence.
9. 8-pin DIN connector which allows the instrument to power the YSI 5010 self-stirring BOD probe	No power supply needed for the DO probe which means one less cable to clutter your work space.
10. Computer interface control	Allows you to control the functions of the instrument from a computer.
11. Audio & tactile keypad response	Affirmation of successful key strokes reduces errors and uncertainty.
12. Real-time clock	For recalling or downloading data, this is essential.

## Model 5100 Features

The YSI Model 5100 has all of the same functionality of the Model 5000 and much more.

The YSI Model 5100 is a state-of-the-art, microprocessor-based, dissolved oxygen instrument with many automated and application specific features.

The YSI 5100 DO instrument contains built-in application software for the calculation of Oxygen Uptake Rate (OUR) and Specific Oxygen Uptake Rate (SOUR). These application features simplify compliance with USEPA 503 regulations for vector attraction and provide useful tools for plant operation decisions.

For laboratories with larger volumes, the Model 5100 offers an optional bar code reader and *BOD Analyst* software capability. These tools greatly reduce the labor required for processing BODs and calculating BOD values. The RS232 serial port makes it easy to capture data electronically.

The model 5000 and 5100 software can be upgraded easily using your computer. When YSI upgrades these instruments, you'll be able to get a floppy disk from YSI and simply upgrade the software in a few minutes.

Calibration of the Model 5100 has been greatly simplified when compared to other dissolved oxygen instruments. With its internal barometer, the Model 5100 is able to automatically compensate for changes in barometric pressure so there is no need for charts, altitude information or external barometric pressure information. The 5100 also has a membrane integrity feature which will notify you when the membrane needs to be changed.

### Model 5100 Features & Benefits

The Model 5100 has all the same functionality as the Model 5000, but with these additional features:

<b>Additional Feature</b>	<b>Benefit</b>
1. Built-in application software for OUR/ SOUR	Easy compliance with USEPA 503 regulations.
2. Internal barometer	No need to consult external barometer and perform manual barometric pressure compensation.
3. Automated calibration	Saves time and extra steps of manual calibration.
4. Bar-code capability	No need to manually type or write the bottle number on your bench sheet.
5. Port for computer keyboard	For some applications, using a keyboard for data entry will be faster than using the instrument keypad.

## 2. Specifications

---

### *Oxygen Measurement*

- Ranges:**      **mg/L:** 0.0 to 60.0 mg/L  
                  **% air saturation:** 0.0 to 600.0% air saturation  
                  **mbar:** 0 to 1500
- Accuracy:**   **mg/L:**  $\pm 0.1\%$  plus 1 Least Significant Digit (LSD)  
                  **% air saturation:**  $\pm 0.1\%$  plus 1 LSD  
                  **mbar:**  $\pm 1\%$  plus 1 LSD
- Resolution:** **mg/L:** 0.1%, or 0.01 mg/L , whichever is greater  
                  **% air saturation:** 0.1% air saturation  
                  **mbar:** 1 mbar

### *Temperature Measurement*

- Range:**        -5.0 to +50.0°C
- Accuracy:**    $\pm 0.1^\circ\text{C}$
- Resolution:**  0.01°C

### *Barometric Pressure Measurement*

- Range:**        450 to 825 mmHg (600 to 1100 mbar)
- Accuracy:**    $\pm 1\%$  plus 1 LSD within  $\pm 10^\circ\text{C}$  ambient temperature from calibration point
- Resolution:**  1 mmHg

### *Temperature Compensation*

The mg/L mode is automatically temperature-compensated to an accuracy of  $\pm 1\%$  of DO readings between 0 and 5°C, and to an accuracy of  $\pm 0.6\%$  of readings between 5 and 45°C.

The % air saturation mode is automatically temperature-compensated to an accuracy of  $\pm 0.5\%$  of calibration values between 0 and 5°C, and to an accuracy of  $\pm 0.3\%$  of values between 5 and 45°C.

## *Salinity Compensation*

**Range:** 0.0 to 40.0 ppt

**Accuracy:**  $\pm 0.02$  mg/L

## *Operating Environment*

0 to 45°C, 10 to 90% relative humidity, non-condensing

## *Water Resistance*

The Model 5000 and 5100 are designed exclusively for indoor use and are NOT waterproof.

## *Power*

The Model 5000 & 5100 are powered by an AC adapter or 4 C-size alkaline batteries. A new set of alkaline batteries will power the selected instrument for approximately 30 hours (not including stirring).

## *Size and Weight*

22.9 by 24.1 by 11.2 cm; 1.1 kg (with batteries)

9 by 9.5 by 4.4 inches; 2.6 pounds (with batteries)

## 3. Quick Start

---

When you unpack your new Model 5000 or 5100 there are several things you'll want to do to set the instrument up.

1. Inspect the product to assure that it has not been damaged during shipment.
2. Check the packing list to make sure you have received everything you should have.
3. Install the batteries (see *11. Maintenance, Batteries*).
4. Plug the power supply into its mating connector on the back of the meter (see *4.3 Rear Panel*).
5. Prepare the DO probe, as discussed in the Probe Operations Manual, and plug it into the connector on the back of the instrument.
6. Depress the  $\text{\textcircled{O}}$  (on/off ) key (see *4.1 Front Panel*).
7. Set the date and time (see *5.4 System Setup*).
8. Calibrate the system in a known oxygen environment (see *6.1 Dissolved Oxygen Calibration*).

You are now ready to make dissolved oxygen and temperature readings.



## 4. Controls

---

### 4.1 Front Panel

The front panel of the instrument contains the display and keypad as shown below. The front panel display and controls of the 5000 and 5100 are identical.

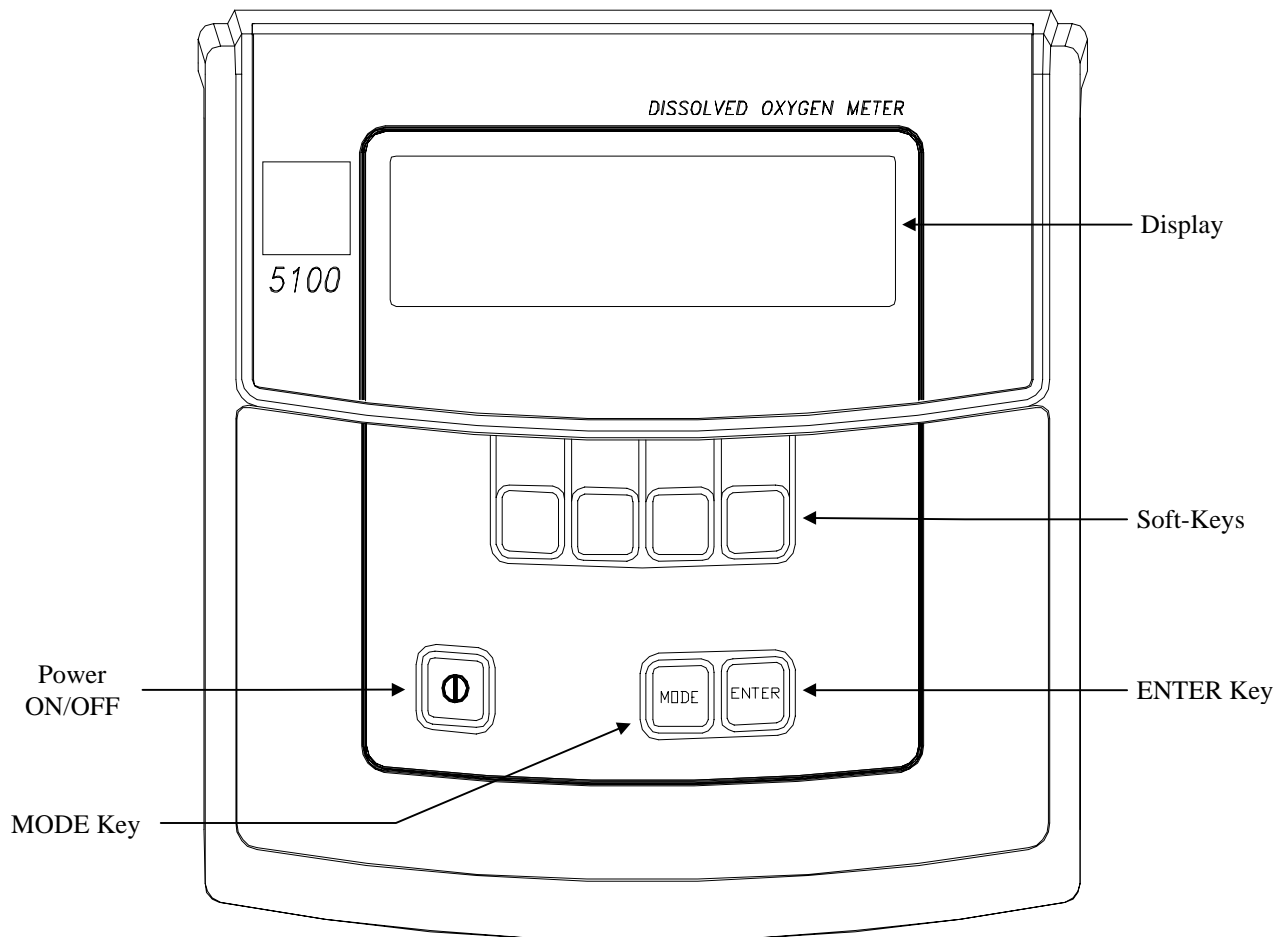

The 5000/5100 has two main operating modes, Main and Application. The current mode is displayed in the dark bar at the top right corner of the display. The following diagram shows the display while the instrument is in the Main mode.

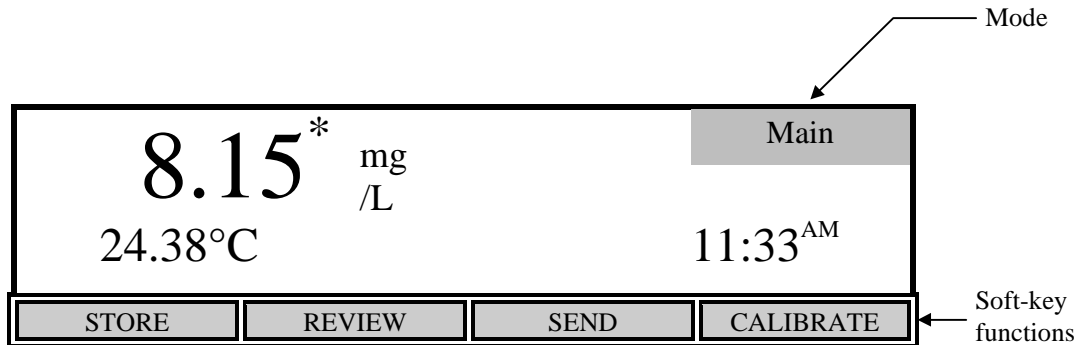

The bottom row of the display identifies the function of the four soft-keys which are located on the keypad below the display. The function of each of these keys changes with each mode.

The [Mode] key and soft-keys are used to navigate through the menus. The [Mode] key is used to cycle between the two main operating modes. Pressing a soft-key will bring up a new set of soft-key functions (menu). The [Mode] key is also used to backup through the menus to the top level.

## 4.2 Software Flow Chart

The following section shows the software flow chart for the 5000/5100. The two operating modes, Main and Application, are shown at the top with the soft-key functions that are accessed in each mode below them. Functions in shaded boxes are only available on the model 5100.

# 5000/5100 Software Flow Chart

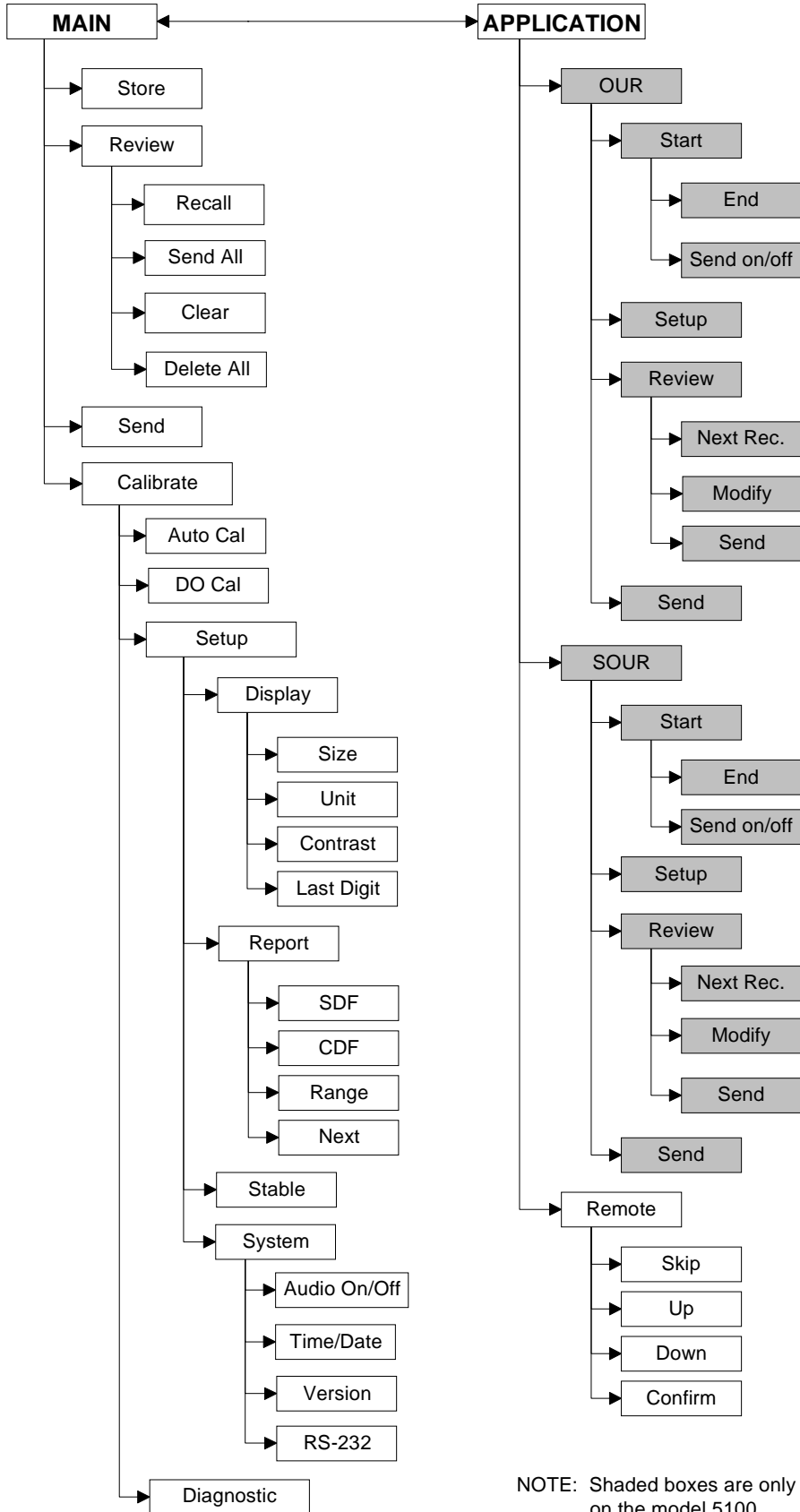

NOTE: Shaded boxes are only available on the model 5100.

### 4.3 Rear Panel

The rear panel contains the connections for the power supply, probe, bar code reader, external computer keyboard and RS232 serial port as shown below. The bar code reader and external computer keyboard share the same socket and are only available on the model 5100.

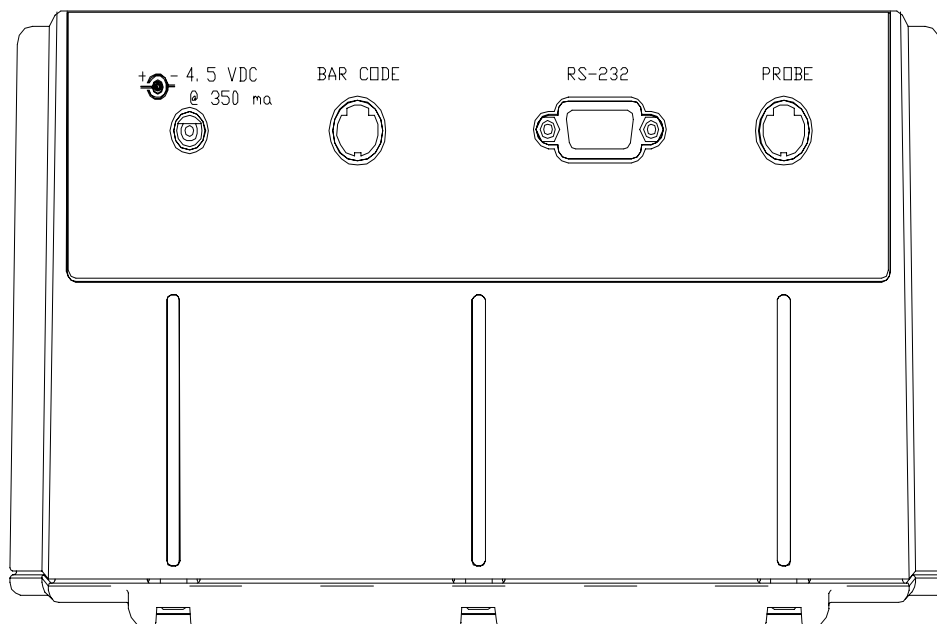

#### ***Power Supply Connection***

The power supply connection requires a 4.5 to 5.5 VDC power supply with at least 350 mA current (6.0 VDC 800 mA when using the YSI 5015 bar code reader).

#### ***Probe Connection***

The connector for the probe is an 8-pin mini DIN connector and is marked with an arrow to show proper alignment. Be sure to align the arrows when plugging in the probe.

YSI 5000 series probes, such as the YSI 5010 BOD probe, will plug directly into the 5000/5100. If you have an older YSI 5700 or 5900 series probe, the YSI 5011 adapter will be required.

The YSI 5011 adapter has a mini-DIN connector at one end and a 5-pin MS connector and probe power connector at the other end. The 8-pin mini-DIN connector plugs into the 5000/5100 probe socket and the 5-pin MS connector plugs into a 5700 or 5900 series probe/cable. The power connector plugs into the matching connector on a self stirring BOD probe. This allows the 5000/5100 to power the BOD probe, eliminating the need for a separate probe power supply.

**NOTE:** Do NOT plug the 5011 adapter power connector into the 5000/5100 power supply socket. Doing so will prevent the 5000/5100 from operating.

### ***Bar Code Reader Connection***

The YSI 5015 bar code reader connects to this 6-pin mini DIN connector. The connector is marked with an arrow to show proper alignment. Be sure to align the arrows when plugging in the YSI 5015 bar code reader (see *7.2 Application Mode, Remote, Bar Code Reader*).

The bar code connector is also used for attaching an external computer keyboard. Using a keyboard simplifies data entry when using the 5100 in the remote mode, such as with YSI *BOD Analyst* software (see *7.2 Application Mode, Remote*).

### ***RS232 Connection***

The RS232 connection is a standard DB9 connector. See *7.2 Application Mode, Remote, System Setup* for details.

## 5. Setup

---

Before operating the 5000/5100 for the first time, you should set the instrument parameters. Once set, these parameters are maintained in memory. These parameters are discussed below.

From Main mode, press the [CALIBRATE] soft-key to enter the calibration menu. Notice that the dark bar in the top right corner of the display shows the current mode.

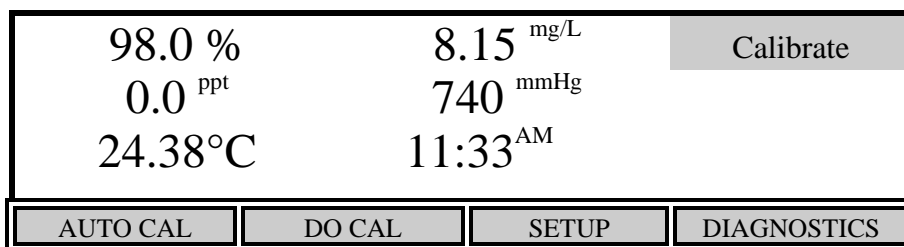

Next, press the [SETUP] soft-key to enter the Setup menu. The bottom row of the display will show the following soft-key setup selections.

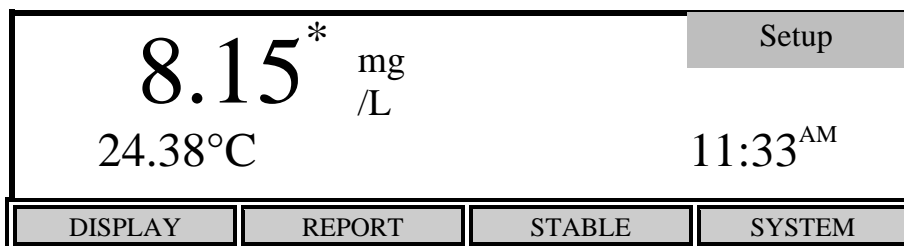

These four selections are used to change the instrument setup.

## 5.1 Display Setup

Press the [DISPLAY] soft-key to show the following menu.

8.15 <sup>*</sup> mg/L			Display
24.38°C		11:33 <sup>AM</sup>	
SIZE	UNITS	CONTRAST	LAST DIG.

The [SIZE] soft-key cycles among the two possible display arrangements for Main mode. One selection shows as many parameters as possible, the other shows Dissolved Oxygen in large type with temperature and time in small type. These different display arrangements are for Main mode only. The display will show all parameters in Calibration mode.

98.0%	8.15 mg/L	Display	
0.0 ppt	740 mmHg		
24.38°C	11:33 <sup>AM</sup>		
SIZE	UNITS	CONTRAST	LAST DIG.

The [UNITS] soft-key brings you to the [UNITS] menu. Use the [UP] and [DOWN] soft-keys to change the measurement units. If you have selected the size to be large, only the DO units selected on the [UNITS] screen will be shown. When the size is set to small, both % and mg/L will be shown. The Date Format is also used to change from a 2 digit year to 4 digit year. The Sal – 78 scale give salinity in unitless values as the measurements are in reference to the conductivity of standard seawater at 15 °C. The HOUR units switch from a 12 to 24 hour day. Press the [MODE] key to return to the Display menu.

DISPLAY UNIT SETUP		Units
D.O.	[ % ]	
Barometer	[ in Hg ]	
Salinity	[ Sal - 78 ]	
Temperature	[ C ]	
Date Format	[ MM/DD/YY ]	HOUR [12H]

UP	DOWN		NEXT
----	------	--	------

The [CONTRAST] soft-key allows the user to change the display contrast. The display contrast will change slightly each time the [UP] or [DOWN] soft-key is pressed.

The [LAST DIG.] soft-key allows the user to suppress the last digit of the DO reading. This function is only available when the large size display has been selected. The small size display will not be affected.

<div style="display: flex; justify-content: space-between;"> <div style="text-align: center;"> <p style="font-size: 2em; margin: 0;">8.2<sup>*</sup></p> <p style="margin: 0;">mg /L</p> </div> <div style="text-align: center;"> <p style="font-size: 1.5em; margin: 0;">24.38°C</p> </div> <div style="text-align: center;"> <p style="font-size: 1.5em; margin: 0;">11:33<sup>AM</sup></p> </div> </div>		Display	
SIZE	UNITS	CONTRAST	LAST DIG.

Press the [MODE] key to return to the Setup menu. If you wish to return to Main mode, press [MODE] two more times.



## 5.2 Report Setup

From the Setup menu, press [REPORT] to display the following soft-keys.

[SDF] Space Delimited Format		Report	
[*] SAMPLE ID #	[*] DATE		
[*] DO%	[*] TIME		
[*] DO mg/L	[*] BAROMETER		
[*] TEMPERATURE	[*] SALINITY		
SEND Record from [ 0] to [99]			
SDF	CDF	RANGE	NEXT

The display lists the parameters that can be included in the output string at the RS232 serial port, the default set has everything selected for inclusion.

You can select the report format that you wish to use by pressing the [SDF] or [CDF] soft-key. Select [SDF] for Space Delimited Format (standard text). If you are going to import the data to a spreadsheet, select [CDF] for Comma Delimited Format. The following are examples of each format:

### Space Delimited Format

SAMPLE ID	mg/L	%	C	ppt	mmHg	TIME	DATE
ID: 0	7.95	97.3	25.6	0.0	786	15:06:34	01/23/96
ID: 1	7.94	97.1	25.6	0.0	786	15:06:36	01/23/96
ID: 2	7.95	97.2	25.6	0.0	785	15:06:44	01/23/96

## Comma Delimited Format

```
"SAMPLE ID", "mg/L", "%", "C", "ppt", "mmHg", "TIME", "DATE"  
"ID:      0", 7.95, 97.3, 25.6, 0.0, 786, "15:06:34", "01/23/96"  
"ID:      1", 7.94, 97.1, 25.6, 0.0, 786, "15:06:36", "01/23/96"  
"ID:      2", 7.95, 97.2, 25.6, 0.0, 785, "15:06:44", "01/23/96"
```

The asterisk character in front of each parameter indicates that the parameter will be included in the report. Press the [NEXT] soft-key to select the parameter that you want to change. Then press [ENTER] to turn the asterisk character on or off.

NOTE: After pressing [SDF] or [CDF] to choose the report format, press the [MODE] key to exit the Report menu. Do NOT press [ENTER] as this will change the currently selected parameter.

To return to Main mode, press [MODE] two more times.

The [RANGE] soft-key brings up the following soft-key menu.

[SDF] Space Delimited Format	Report		
[*] SAMPLE ID #	[*] DATE		
[*] DO%	[*] TIME		
[*] DO mg/L	[*] BAROMETER		
[*] TEMPERATURE	[*] SALINITY		
SEND Record from [00] to [99]			
UP	DOWN	DIGIT	NEXT

Flashing Cursor

This menu allows specifying a specific range of memory locations for the report. The default range is 00 - 99 and empty locations will not be sent to a computer or serial printer.

The display digit that has the flashing cursor below it is increased or decreased by pressing the [UP] or [DOWN] soft-key. If the [UP] or [DOWN] soft-key is held down, the digit will continue to change until the key is released. The [DIGIT] soft-key makes it easy to make large changes by selecting the digit you wish to change. Press the [NEXT] soft-key to change between the minimum and maximum parameter. When the desired number is obtained, pressing [ENTER] will accept the number and exit the RANGE sub-menu. The RANGE sub-menu can be left without making any changes by pressing the [MODE] key. Operation returns to the report setup menu.

To return to Main mode, press [MODE] three more times.

### 5.3 Autostable Setup

The autostable feature indicates when readings are stable by emitting a single beep and displaying an asterisk (\*) to the right of the dissolved oxygen reading. The instrument uses criteria that you input to determine what a stable reading is. You select the maximum percent of change that may occur during a selected time duration. The default values are 10 seconds and 0.4% variation. The instrument will display an asterisk (\*) only when these criteria are met.

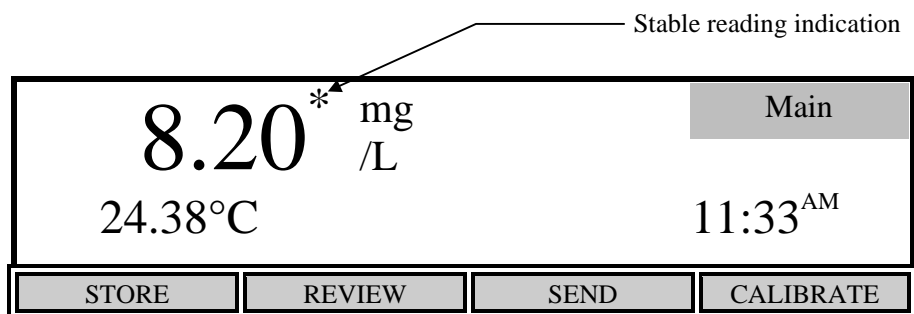

From the Setup menu, press the [STABLE] soft-key to display the following menu.

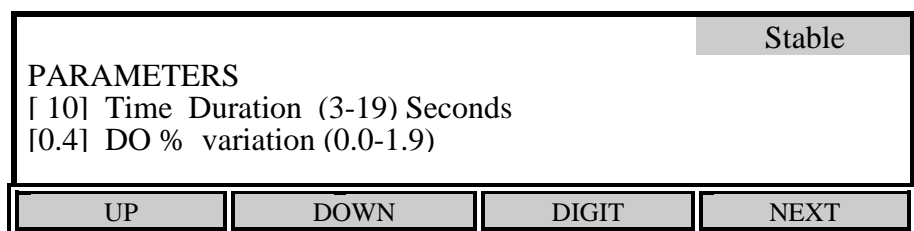

This menu is used to change the autostable criteria. Press the [NEXT] soft-key to select between the time duration and the percent variation. Use the [DIGIT] soft-key to select the digit you wish to change by pressing [UP] or [DOWN]. When you have finished setting the parameters, press [ENTER] to confirm. The STABLE sub-menu can be left without making any changes by pressing the [MODE] key instead of [ENTER]. Operation returns to the setup menu.

If you wish to disable the autostable feature, set the DO% variation to 0.0.

To return to Main mode, press [MODE] two more times.

## 5.4 System Setup

From the Setup menu, press the [SYSTEM] soft-key to display the following menu.

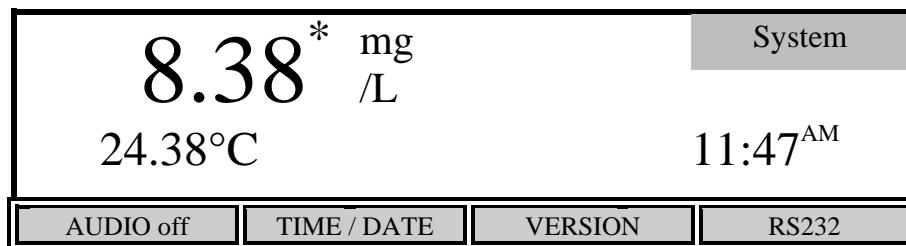

The [AUDIO on/off] soft-key allows setting the beeper on or off. The key toggles between an [AUDIO off] soft-key and an [AUDIO on] soft-key. The present state of the beeper would be the OPPOSITE of the function shown on the soft-key. If the beeper is currently on, the soft-key shows "AUDIO off"; i.e., your alternate choice.

The [TIME/DATE] soft-key brings up the following menu to allow setting of the date and time.

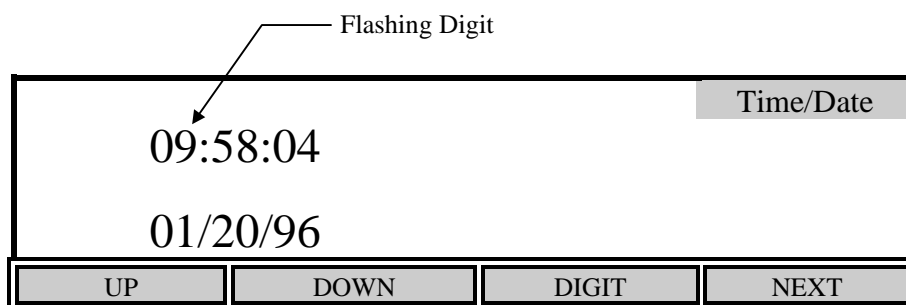

Use the UP, DOWN, DIGIT and NEXT soft-keys to enter the time in 24-hour format. The display digit that is flashing is increased or decreased by pressing the [UP] or [DOWN] soft-key. If the [UP] or [DOWN] soft-key is held down, the digit will continue to change until the key is released. The [DIGIT] soft-key makes it easy to make large changes by selecting the digit you wish to change. After you have set the hour, press the [NEXT] soft-key to move to the next parameter, minutes. Repeat the process for the remaining parameters.

When you have finished entering the time and date, press [ENTER] to confirm and return to the system setup menu. The message "TIME SETTING SAVED" will be displayed on the message line at the bottom of the screen. The Time/Date sub-menu can be left without making any changes by pressing the [MODE] key instead of [ENTER]. Operation returns to the system setup menu.

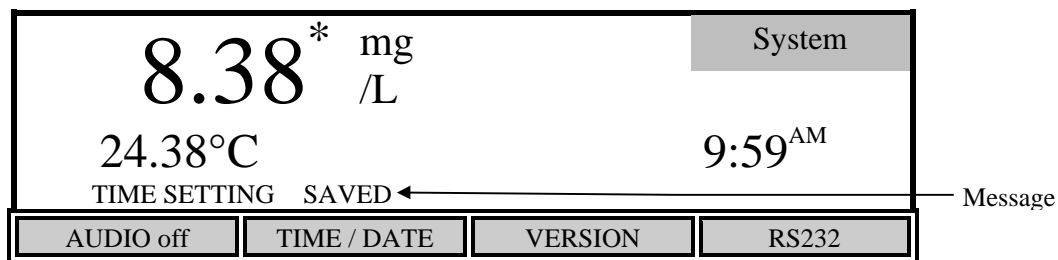

If you wish to return to Main mode, press [MODE] three times.

The [VERSION] soft-key displays the instrument software version on the message line of the display just above the soft-key descriptions.

The [RS232] soft-key displays the RS232 setup.

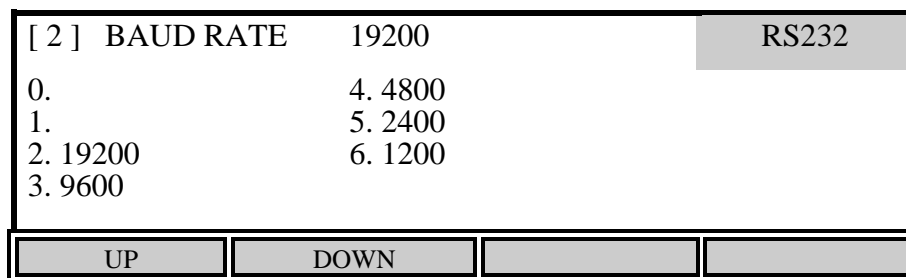

Select the baud rate by pressing the [UP] or [DOWN] soft-keys. The first two choices, 0 and 1, are not currently available.

The remaining RS232 parameters are fixed as follows:

Data Length: 8 bits  
 Parity: None  
 Stop Bits: 1

Press [ENTER] to confirm. The RS232 sub-menu can be left without making any changes by pressing the [MODE] key instead of [ENTER]. Operation returns to the system setup menu.

Press [MODE] to return to the previous menu, Setup. To return to Main mode, press [MODE] two more times.

## 6. Calibration

---

From the Main mode, press the [CALIBRATE] soft-key to enter Calibration mode. The bottom row of the display shows the soft-key menu.

98.0* %	8.15 mg/L	Calibrate	
0.0 ppt	740 mmHg		
24.38°C	11:33 <sup>AM</sup>		
AUTO CAL	DO CAL	SETUP	DIAGNOSIS

### 6.1 Dissolved Oxygen Calibration

Dissolved oxygen calibration can be done automatically with the push of one button (see *Auto Cal*) or manually by entering the desired value in milligrams per liter or percent saturation (see *DO Cal*).

**BEFORE YOU CALIBRATE** you must Setup the meter, as discussed in the *Setup* section of this manual, and Prepare the DO probe as discussed in the Probe Operations Manual. Before performing an AUTO CAL on a Model 5100, you must check the barometric pressure reading and calibrate the barometer, if necessary, as shown under *6.1 Dissolved Oxygen Calibration, Barometer*. The Model 5000 does not contain a barometer, therefore, the current barometric pressure must be entered before an AUTO Cal is performed.

Dissolved oxygen calibration must be done in an environment with a known oxygen content. Three such environments will be discussed here: calibration in air (water saturated), calibration in air-saturated water and calibration by Winkler titration. Choose the **one** which best fits your application. Calibration in air is the simplest and most accurate method of calibration.

- For **air calibration**, place the probe in air at 100% relative humidity. To achieve this, the probe can be placed in a BOD bottle containing 1" of water. No stirring is required in air.
- For **air-saturated water calibration**, air-saturate a volume of water (300 to 500 mL) by aerating for at least 15 minutes at a relatively constant temperature. Place the probe in the aerated water and provide adequate stirring (at least 1 foot per second) while calibrating, such as that provided by the 5010 self-stirring BOD Probe.
- To calibrate **to a Winkler-titrated sample**, determine the dissolved oxygen value of a sample by Winkler titration. Place the probe in the sample and provide adequate stirring (at least 1 foot per second) while calibrating in the manual mode.

NOTE: If you choose calibration by Winkler titration, you cannot use AUTO CAL, you must use DO CAL (manual) mode, since AUTO CAL assumes the probe is in a saturated environment.

## Auto Cal

1. Prepare the probe according to the instructions in the Probe Operations Manual.
2. Connect the probe to the meter.
3. Place the probe in a BOD bottle containing about 1" of water to provide a 100% relative humidity environment.
4. Press [Ⓢ] to turn the instrument on.
5. Allow the probe to polarize and the temperature to stabilize for at least 15 minutes. If calibration is performed prematurely the values will drift and may be out of specification.
6. Press the [CALIBRATE] soft-key to change to Calibration mode. The following display will appear.

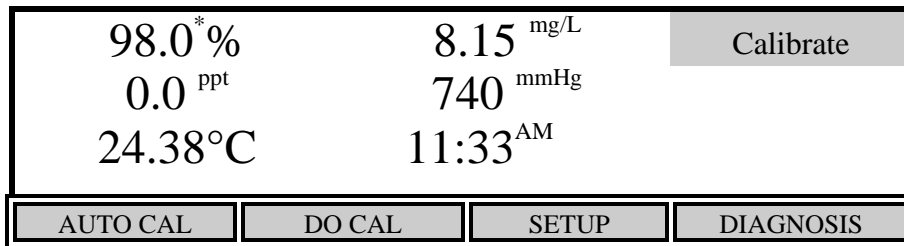

7. **Model 5100:** Verify that the barometer reading is correct. Calibrate the barometer, if necessary, as shown under 6. *Dissolved Oxygen Calibration, Barometer.*

**Model 5000:** Enter the current barometric pressure as shown under 6. *Dissolved Oxygen Calibration, Barometer.*

8. Make sure that the display readings are stable, then press the [AUTO CAL] soft-key to calibrate Dissolved Oxygen. The message "D.O. CALIBRATION SAVED" will be displayed for a few seconds.

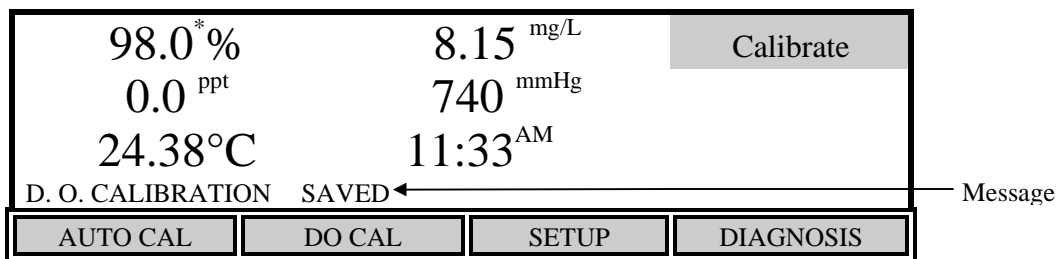

9. Press [MODE] to return to the Main mode. The instrument is now calibrated and ready to measure dissolved oxygen and temperature. See 7.1 *Main Mode, Making Measurements.*

## DO Cal (manual)

1. Prepare the probe according to the probe instructions.
2. Connect the probe to the meter.
3. Place the probe in a known oxygen environment, such as a BOD bottle containing about 1" of water to provide a 100% relative humidity environment or a Winkler-titrated sample.
4. Press [⊕] to turn the instrument on.
5. Allow the probe to polarize and the temperature to stabilize for at least 15 minutes. If calibration is performed prematurely the values will drift and may be out of specification.
6. Press the [CALIBRATE] soft-key to change to Calibration mode. The following screen will be displayed.

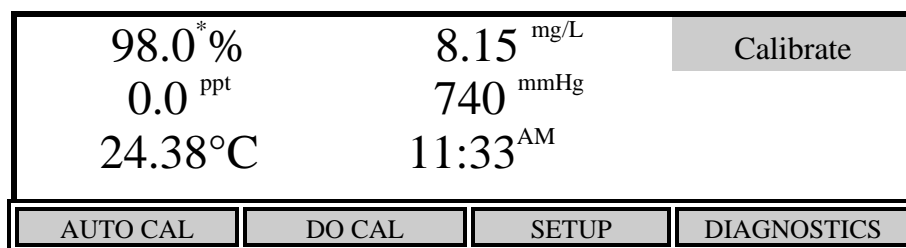

7. Press the [DO CAL] soft-key to enter the manual DO calibration menu.

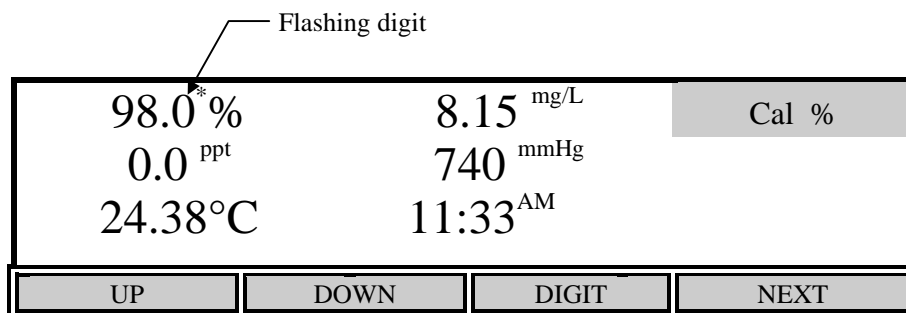

8. Make sure that the display readings are stable, then enter the calibration value in percent saturation, using the [UP], [DOWN] and [DIGIT] soft-keys. See *Appendix A - Oxygen Solubility Table* and *Appendix B - Pressures and Altitudes* for manual calibration data.

If you wish to calibrate in milligrams per liter (instead of percent), verify that the salinity is set to the salinity value of the calibration environment (0.0 ppt for air calibration, see *6.1 Dissolved Oxygen Calibration, Salinity*). Then, use the [NEXT] soft-key to select mg/L and enter the calibration value in milligrams per liter as shown below.



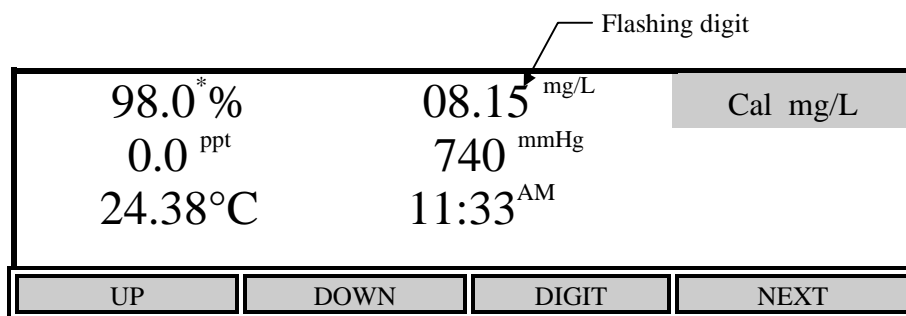

9. Press [ENTER] to confirm your calibration. The screen will momentarily display “D.O. CALIBRATION SAVED” as shown below.

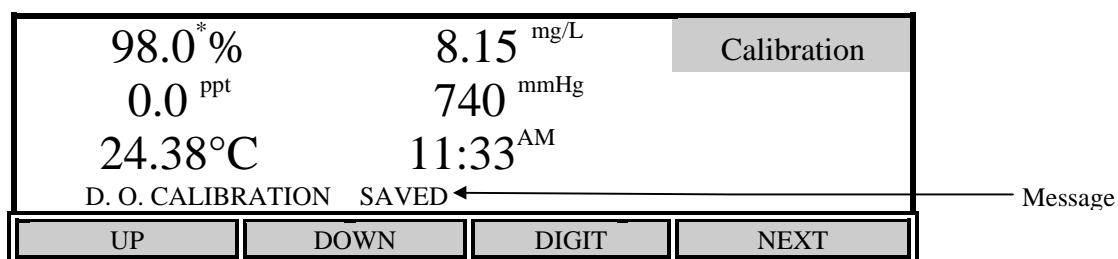

NOTE: If you wish to abort calibration before you have pressed [ENTER], you may press [MODE] to return to the calibrate menu without saving the new calibration value. You may also press [NEXT] to select a different parameter (any change made will not be saved).

10. Press [MODE] to return to the Main mode. The instrument is now calibrated and ready to measure dissolved oxygen and temperature. See *7.1 Main Mode, Making Measurements*.

## Barometer

The YSI Model 5100 has an internal barometer for pressure compensation during AUTO Dissolved Oxygen Calibration. This barometer only needs to be calibrated when it is no longer reading the correct barometric pressure. If the 5100 is kept at a fairly constant ambient temperature ( $\pm 10^{\circ}\text{C}$ ), the barometer calibration should be accurate for approximately 30 days.

The Model 5000 does not contain a barometer, therefore, the current barometric pressure must be entered before an AUTO Cal is performed. The pressure value displayed is the setting that was entered and stored during the previous calibration.

From the calibration menu press the [DO CAL] soft-key, then press the [NEXT] soft-key until the barometric pressure is flashing and “Barometer” appears in the top right corner of the display as follows:

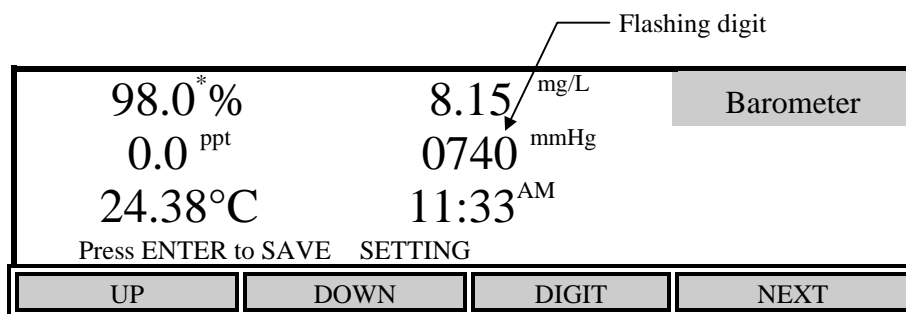

Using the [UP], [DOWN] and [DIGIT] soft-keys, enter the true local barometric pressure. This corresponds to a reading from a mercury barometer. Do **NOT** use the pressure reported by the weather bureau. Weather bureaus correct pressures to sea level.

NOTE: You may estimate the standard pressure at your altitude by using *Appendix B - Pressures and Altitudes*.

Press [ENTER] to confirm. The message “PRESSURE CALIBRATION SAVED” will be displayed, on the model 5100, as shown below. The model 5000 will display “PRESSURE SETTING SAVED”, since it does not contain an internal barometer.

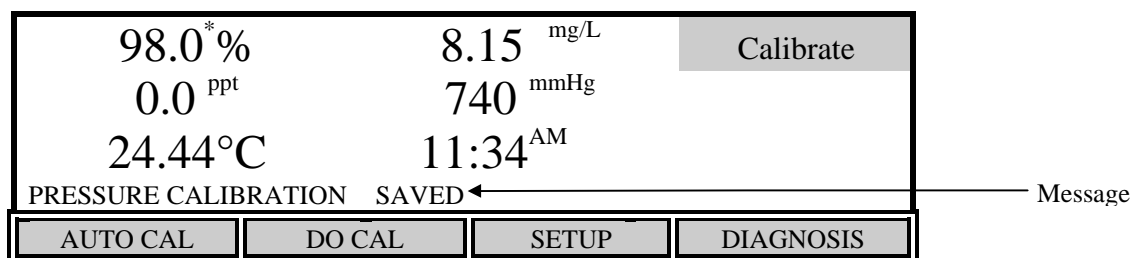

NOTE: If you wish to abort before pressing [ENTER], you may press [MODE] to return to the calibrate menu without saving the new value for barometric pressure. You may also press [NEXT] to select a different parameter (any change made will not be saved).

## Salinity

Salt reduces the ability of water to hold oxygen in solution. Enter the salinity of the sample you are measuring and the meter will automatically compensate for the effect of salinity on dissolved oxygen. The default setting for salinity is 0.0 ppt. You can enter any value between 0.0 and 40.0 ppt.

From the Calibration menu press the [DO CAL] soft-key, then press the [NEXT] soft-key until the salinity value is flashing. The top right corner of the screen will display “Salinity” as shown in the following screen. Remember, if you are manually calibrating in mg/L in water saturated air, salinity is 0.0 ppt.

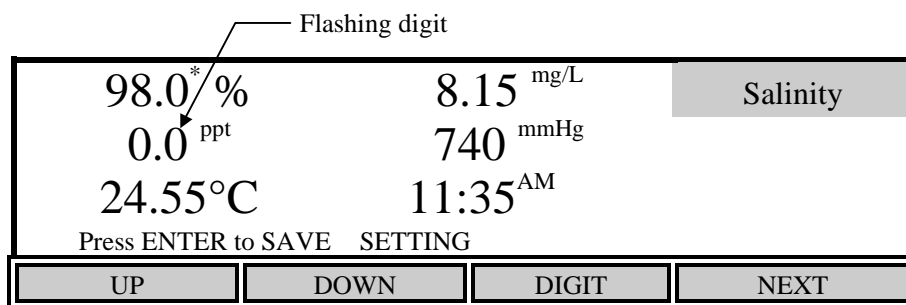

Using the [UP], [DOWN] and [DIGIT] soft-keys, enter the salinity value.

Press [ENTER] to confirm. The message “SALINITY SETTING SAVED” will be displayed as shown below.

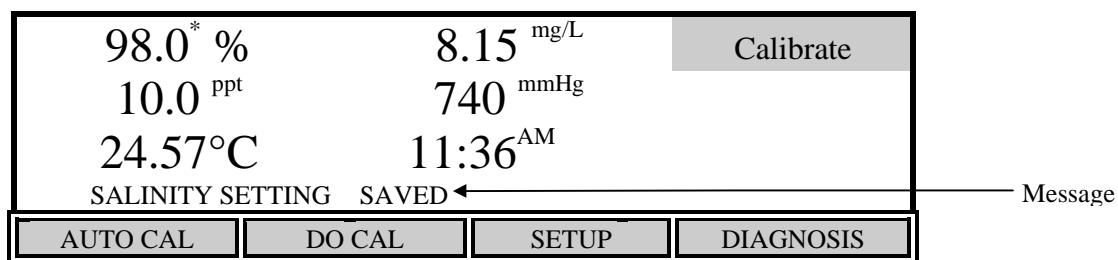

NOTE: For accurate DO readings, the salinity setting MUST match the salinity of each sample measured.

## 6.2 Zero Calibration

In rare applications, the accuracy of the calibration can be improved by performing a zero calibration along with one of the procedures discussed previously.

All oxygen probes have a small background current, even in the absence of oxygen. Model 5000/5100 compensation is based on the average background current of YSI probes. This is the default zero value. Using this average will result in errors with probes whose background current differs from the average.

**Note: Errors will be insignificant in most applications.** See 10. *Understanding Dissolved Oxygen Error Factors.*

For highest accuracy measurements, a zero calibration should be performed to compensate for the specific background current of the probe in use.

To calibrate to a true zero, place the probe in a zero oxygen environment and adjust the calibration value to zero.

A standard method for creating such an environment is to dissolve excess sodium sulfite ( $\text{Na}_2\text{SO}_3$ ) and a trace of cobalt chloride ( $\text{CoCl}_2$ ) in water. Preferably, the water should come from the sample to be measured. These chemicals will remove all oxygen from the sample (See Standard Methods for the Examination of Water & Wastewater, method 4500-O G, 19th edition). Alternatively, you may place the probe in 100% nitrogen gas.

1. Place the probe in the zero oxygen sample and allow at least 20 minutes for the probe to come to equilibrium.
2. Press the [CALIBRATE] soft-key to change to Calibration mode. The following screen will be displayed.

98.0* %	8.15 mg/L	Calibration	
0.0 ppt	740 mmHg		
24.38°C	11:33 <sup>AM</sup>		
AUTO CAL	DO CAL	SETUP	DIAGNOSTICS

3. Press the [DO CAL] soft-key to enter the manual DO calibration menu.

000.0* %	0.00 mg/L	Cal %	
0.0 ppt	740 mmHg		
24.38°C	11:33 <sup>AM</sup>		
UP	DOWN	DIGIT	NEXT

4. Make sure that the display readings are stable, then use the [UP], [DOWN] and [DIGIT] soft-keys to enter the calibration value of 0.0% (or 0.00 mg/L).

NOTE: The instrument will not except any value other than zero for the first point of a two-point calibration.

5. Press [ENTER] to confirm your calibration. The screen will momentarily display “D.O. CALIBRATION SAVED”.

The Model 5000/5100 is calibrated at two points: the calibration value you select, and its default zero.

**NOTE:** When you change the zero calibration point, you offset the other value, so that after zeroing the probe for zero oxygen, you must recalibrate in an oxygen environment.

6. You must now recalibrate in an oxygen environment (see *6.1 Dissolved Oxygen Calibration, Auto Cal or DO Cal*).

## 7. Operation

---

### 7.1 Main Mode

When the instrument is turned on it is in the Main mode. The following chart shows the display during Main mode operation.

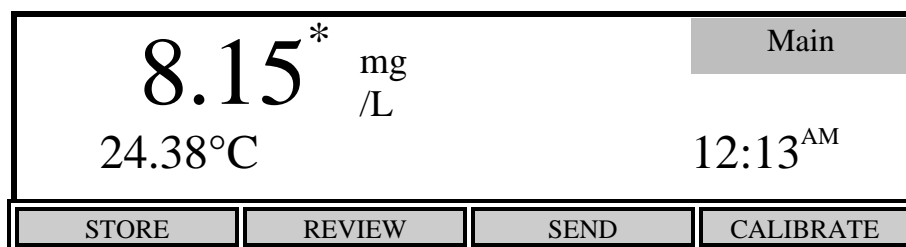

The bottom row of the display shows the functions of the four soft-keys used during Main mode. Main mode is used to make measurements, store or review readings and send the current readings to a computer or serial printer.

### Making Measurements

Main mode is used to make dissolved oxygen and temperature measurements as follows:

1. Make sure that the instrument has been properly calibrated (see 6. *Calibration*).

NOTE: If the instrument has just been turned on, allow at least 15 minutes for the probe to polarize and the temperature to stabilize before calibrating.

2. Verify that the salinity of the sample matches the salinity setting of the instrument (see 6.1 *Dissolved Oxygen Calibration, Salinity*).
3. Place the probe in the sample.
4. Provide adequate stirring (at least 1 foot per second), such as that provided by the 5010 self-stirring BOD Probe.
5. Allow time for the temperature and dissolved oxygen readings to stabilize. The amount of time varies with temperature, the condition of the probe and the dissolved oxygen level.
6. Read the dissolved oxygen and temperature.

NOTE: Temperature compensation of the dissolved oxygen reading is automatically determined.

## Store

Press the [STORE] soft-key to enter Store mode and display the following menu.

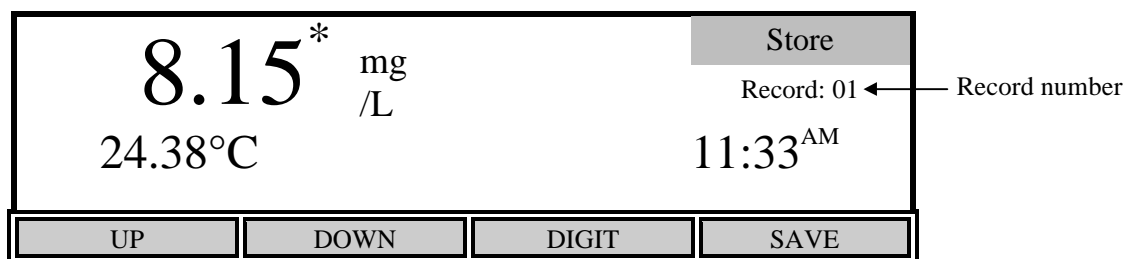

The Store menu is used to control the storing of data. The current record number is shown in the display on the right side.

Press the [SAVE] soft-key to store the values currently displayed. The message "Record X SAVED" (where X is the record number) will momentarily be displayed on the screen and the record number will increase to the next memory location.

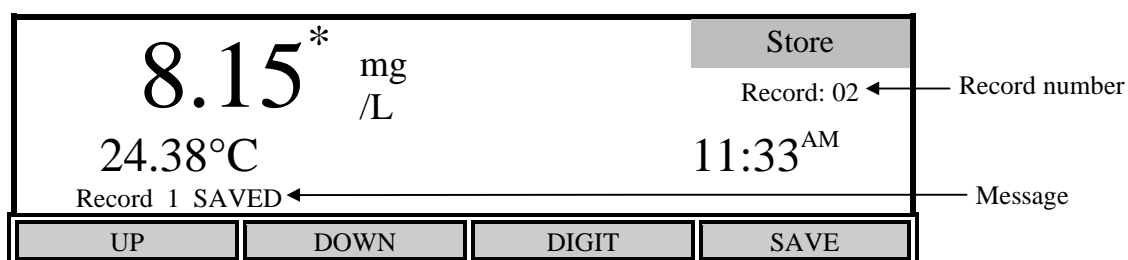

If you wish to store a record at a location other than the current one, use the [UP], [DOWN] and [DIGIT] soft-keys to select the memory location desired.

If the current record location contains data, you will see the following display to warn you that the current memory location contains data.

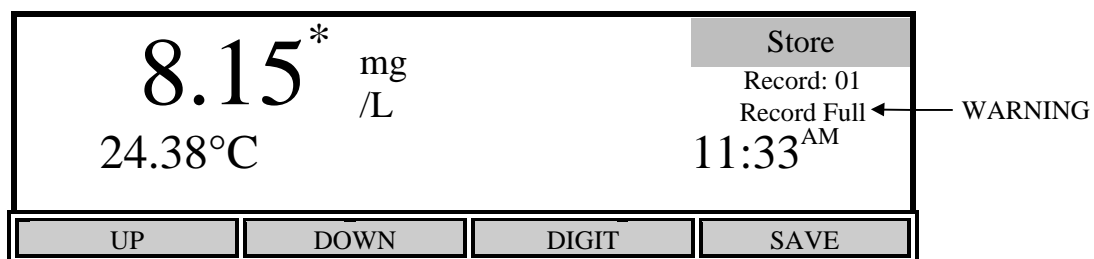

If the current memory location already contains data and you press [SAVE], the current readings will be stored and the previous readings will be erased.

**NOTE: There is NO way to restore previous data once it has been deleted.**

When you have finished storing records, press [MODE] to return to Main mode.

### Review

Press the [REVIEW] soft-key to enter Review mode and display the following menu.

98.0 %	8.15 <sup>mg/L</sup>	Review	
0.0 <sup>ppt</sup>	740 <sup>mmHg</sup>	Record: 01	
24.38°C	11:33 <sup>AM</sup>	Record Full	
		02/06	
RECALL	SEND ALL	CLEAR	DEL. ALL

### Recall

From the Review menu, press the [RECALL] soft-key to enter Recall mode and display the following menu.

98.0 %	8.15 <sup>mg/L</sup>	Recall	
0.0 <sup>ppt</sup>	740 <sup>mmHg</sup>	Record: 01 ← Record number	
24.38°C	11:33 <sup>AM</sup>	Record Full	
		02/06	
UP	DOWN	DIGIT	SEND

The Recall menu is used to recall or send data that was previously stored. The current record number is shown on the right side of the display.

Use the [UP], [DOWN] and [DIGIT] soft-keys to view a different record number.

Press the [SEND] soft-key to send the currently displayed record to a computer or serial printer via the RS232 port.

When you have finished recalling records, press [MODE] two times to return to Main mode.

### Send All

From the Review menu, you may send ALL stored data to a computer or serial printer by pressing the [SEND ALL] soft-key. See 5.2 *Report Setup* for format.

### Clear

From the Review menu, press the [CLEAR] soft-key to enter Clear mode and display the following menu.

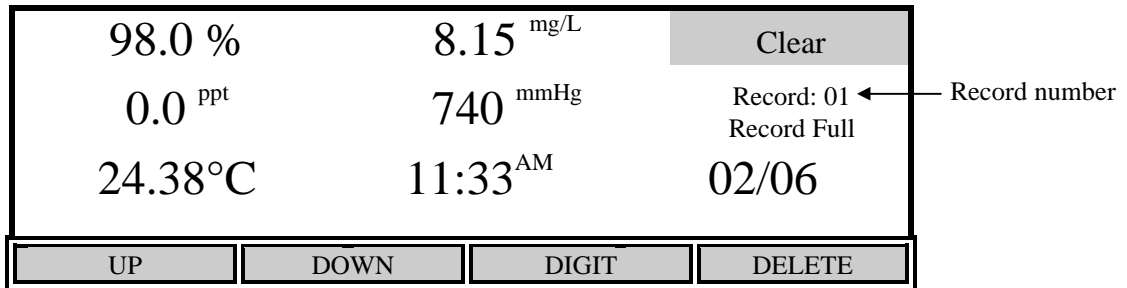

The Clear menu is used to delete data that was previously stored. The current record number is shown in the display on the right side.

Use the [UP], [DOWN] and [DIGIT] soft-keys to select the record that you want to delete. Press the [DELETE] soft-key to delete the selected record.

NOTE: It is not necessary to clear records before new data can be stored. The new data will overwrite the previous data.

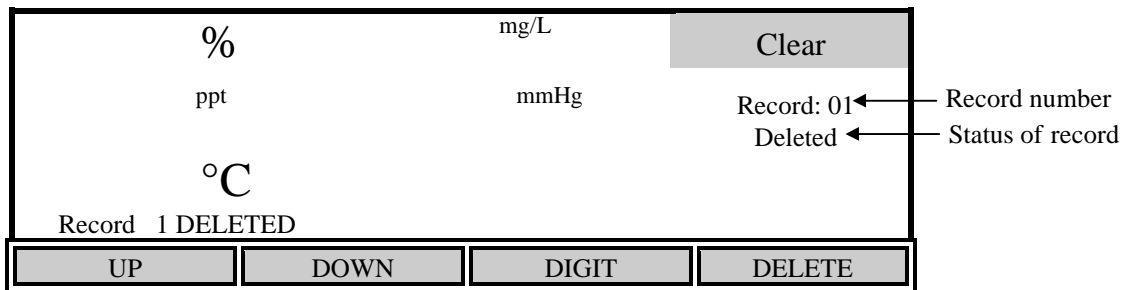

**NOTE: There is NO way to restore data once it has been deleted.**

When you have finished deleting records, press [MODE] two times to return to Main mode.



### Delete All

To delete ALL stored data, press the [DEL. ALL] soft-key to display the following:

98.0 %	8.15 mg/L	Delete All	
0.0 ppt	740 mmHg	Record: 01 ← Record number	
24.38°C	11:33 <sup>AM</sup>	Record Full	02/06
Press ENTER to DELETE ALL			
RECALL	SEND ALL	CLEAR	DEL. ALL

Press [ENTER] to confirm your decision and delete ALL stored data. Press [MODE], instead of [ENTER], if you wish to abort.

**NOTE: There is NO way to restore data once it has been deleted.**

Press [MODE] to return to Main mode.

### Send

While in the Main menu, the [SEND] soft-key is used to send the current live display readings to a computer or serial printer via the RS232 port. This is an alternative to storing results, recalling them, and then printing them.

8.15* mg/L	Main		
24.38°C	11:33 <sup>AM</sup>		
STORE	REVIEW	SEND	CALIBRATE

Each time you press the [SEND] soft-key, on the model 5100, the current display values are sent, along with the salinity setting, date and barometric pressure reading. The model 5000 prints the same information, however, the barometric pressure is the current setting and not a reading. The output format can be changed under 5.2 *Report Setup*. The following are examples of the send format:

#### Space Delimited Format

mg/L	%	C	ppt	mmHg	TIME	DATE
8.69	98.5	21.5	0.0	797	10:17:30	02/06/96

### Comma Delimited Format

```
"mg/L", "%", "C", "ppt", "mmHg", "TIME", "DATE"  
12.19,138.2,21.6, 0.0, 790, "10:20:56", "02/06/96"
```

NOTE: If you want to send stored records, you must first enter Recall mode (see *7.1 Main Mode, Review, Recall*).

## 7.2 Application Mode

The YSI Model 5100 DO instrument contains built-in application software for the calculation of Oxygen Uptake Rate (OUR) and Specific Oxygen Uptake Rate (SOUR). These application features may simplify compliance with USEPA 40 CFR Part 503 regulations for vector attraction and provide useful tools for plant operation decisions. With the Model 5100 complete sets of data from five OUR tests and five SOUR tests can be stored to memory and later reviewed.

From the Main mode, press the [MODE] key to enter the Application mode. The bottom row of the display shows the soft-key menu of the Model 5100. The Model 5000 does not support OUR or SOUR applications. The 5000 does, however, support Remote mode which allows the instrument to be controlled via computer.

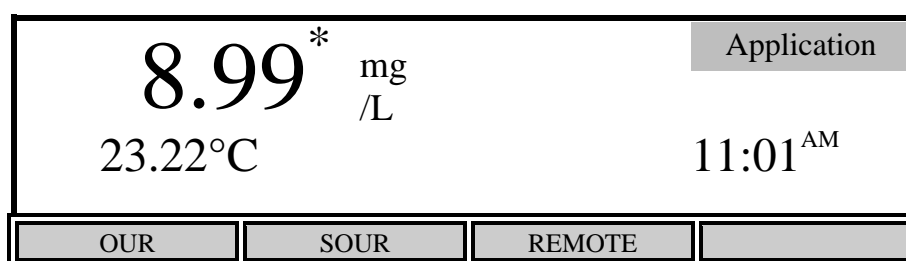

### OUR

The 5100 uses the following formula to calculate the OUR value:

$$\text{OUR} = \frac{\text{DO}_{\text{START}} - \text{DO}_{\text{END}}}{\text{T}_{\text{ELAPSED}}} \times \frac{3600 \text{ Sec}}{1 \text{ Hour}} \times \frac{\text{Total Volume}}{\text{Sample Volume}} = \text{mg/L/h}$$

Where:

$\text{DO}_{\text{START}}$  = Dissolved oxygen level at start of test

$\text{DO}_{\text{END}}$  = Dissolved oxygen level at end of test

$\text{T}_{\text{ELAPSED}}$  = Elapsed time of test in seconds

$\frac{\text{Total Volume}}{\text{Sample Volume}}$  = Dilution factor of sample (entered in setup screen as Sample / Total)

From the Model 5100 Application mode menu press the [OUR] (Oxygen Uptake Rate) soft-key. The following screen will be displayed.

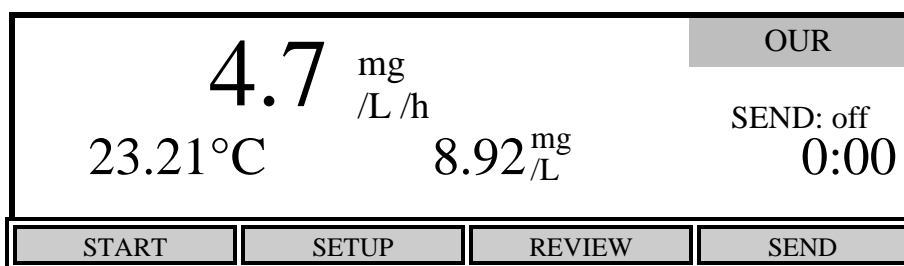

Press [SETUP] to change the OUR parameters. The following screen shows the default parameters.

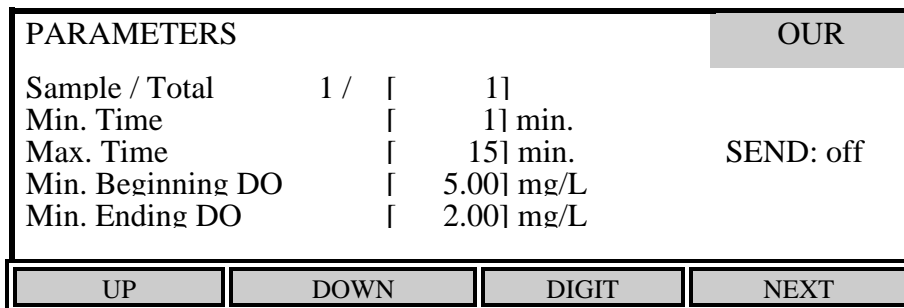

Use the [UP], [DOWN], [DIGIT] and [NEXT] soft-keys to change the following parameters as necessary:

- Sample / Total: Enter the ratio of sample volume to total volume. For example, if you are diluting 1 to 10 (1 part sample plus 9 parts dilution water), then enter the number 10. This would be a 10-fold dilution.
- Min. Time: Enter the minimum time (in minutes).
- Max. Time: Enter the maximum time (in minutes). When the maximum time is reached, the test will end.
- Min. Beginning DO: Enter the minimum level of DO allowed at the start of the test.
- Min. Ending DO: Enter the minimum level of DO allowed during the test. If the DO level falls below this value, the test will end.
- SEND: on/off This sets the RS232 status at the beginning of the test.

After the parameters have been set, press [ENTER] to save them and return to the OUR menu.

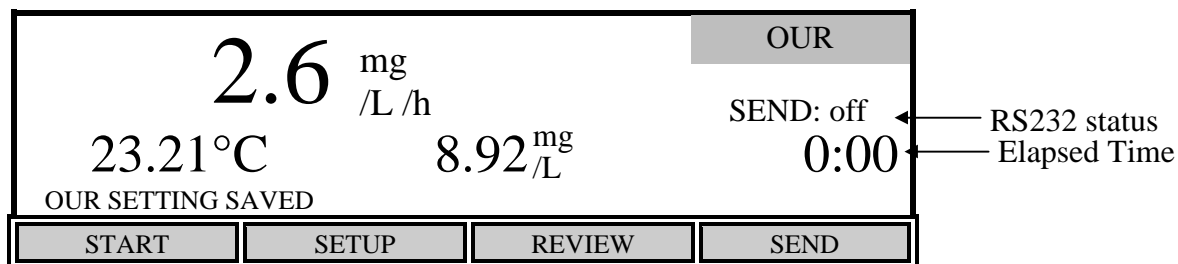

Once the parameters have been set, you are ready to begin. Place the probe in the prepared sample and make certain no air bubbles are trapped, then turn on the stirring and wait a few seconds for the temperature readings to stabilize.

NOTE: It is normal for the OUR reading to oscillate for the first few seconds.

Press [START] to begin the OUR measurement. The following screen shows the available soft-keys after the test is started.

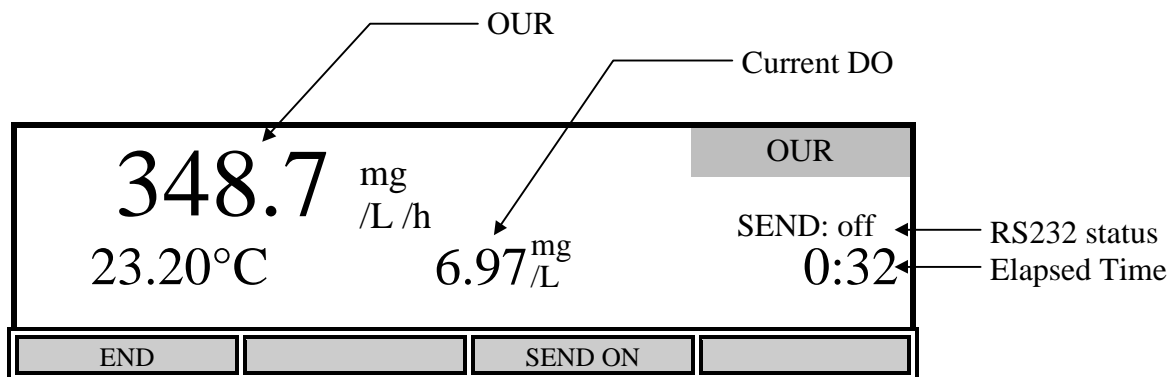

The OUR value is displayed on the screen and is updated approximately once per second.

The [SEND ON/OFF] soft-key toggles the RS232 status. Press [SEND ON] if you want to send the readings to a computer or serial printer during the OUR measurement. The RS232 status is displayed just above the elapsed time. During the OUR measurement, data will be sent every 15 seconds until the OUR measurement ends or the [SEND OFF] soft-key is pressed. The following is an example of the format:

NOTE: Once pressed, the [SEND ON] soft-key toggles and becomes a [SEND OFF] soft-key.

```

Second mg/L/h    C    mg/L  11:04:10  09/21/98
0     0.23 23.20  8.52
15   595.27 23.20  7.28
30   369.63 23.20  6.98
45   275.23 23.20  6.80  . . .

```

If you want to stop the OUR measurement before the maximum time or minimum ending DO (entered in OUR setup) is reached, press [END]. The final OUR reading will be displayed on the screen.

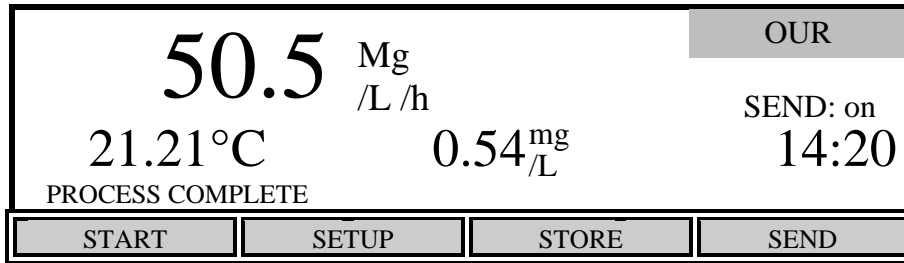

NOTE: The DO and temperature readings do not stop updating on the screen.

After the OUR measurement has ended, the [SEND] soft-key can be used to send all of the DO values and the final OUR reading to a computer or serial printer via the RS232 port. The format is as follows:

Time stamp: 11:04 AM

Date stamp: 09/21/98

Reference point: 105 (sec.)

Second mg/L

0	8.52
15	7.28
30	6.98
45	6.80
60	6.66
75	6.53 . . .
863	1.99

OUR = 50.53 mg/L/h

Dilution ration: 1 / 2(Sample/Total)

NOTE: If you have run an OUR measurement, but did not enter the appropriate sample dilution, you will get uncorrected results. However, after running the OUR measurement, you may return to the OUR setup screen, change the Sample/Total ratio, then press [ENTER] to save the changes. The recalculated OUR value will be displayed. Press [SEND] to send the new OUR value to a computer or serial printer via the RS232 port.

If you want to save these values press the [STORE] soft-key. A record number will then show up under the REVIEW menu. If the record slot contains a set of data, an indicator saying FULL will appear beside the test number. If the record slot does not contain a set of data, the indicator will say EMPTY.

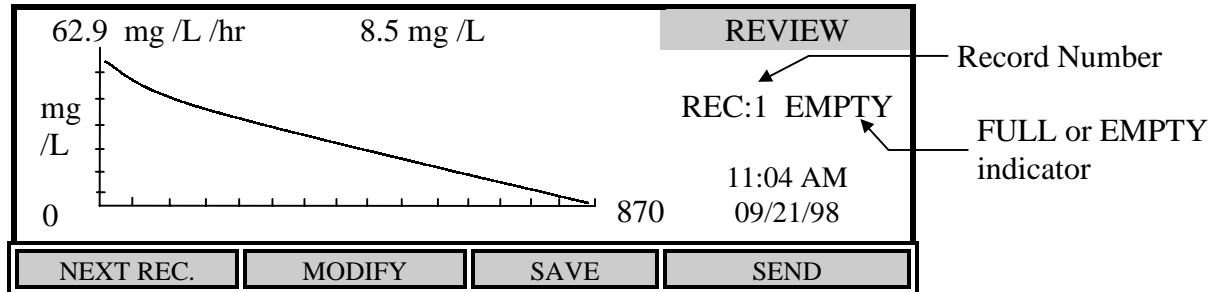

Press the [NEXT REC.] soft-key to change the record number to find an empty slot, or pick a slot to overwrite (you cannot delete records, you must overwrite). Press the [SAVE] soft-key to save the current test data into that slot. Once you have saved the data you can press the [MODIFY] soft-key to change some parameters of the test.

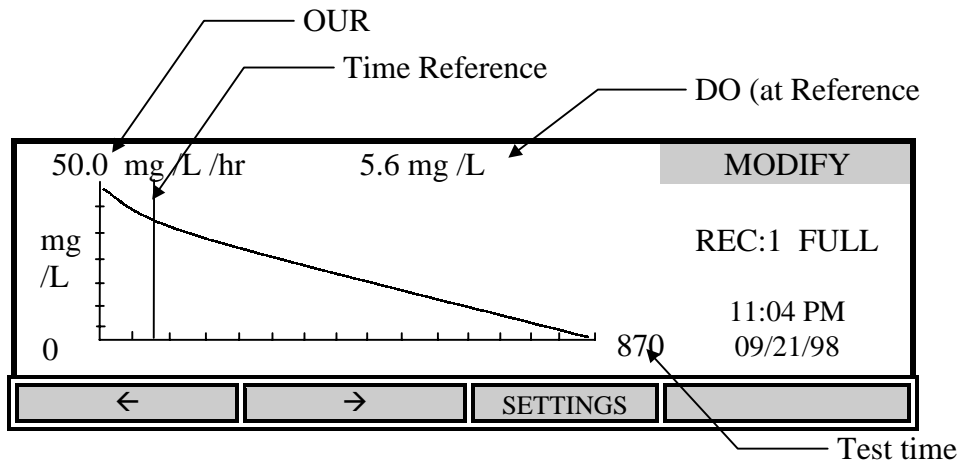

Press the < or > soft-keys to move the start time reference point to an optimal place on the curve. The reference point is represented by a vertical line. Only data to the right of the reference point will be used to calculate the OUR value. Moving this reference point allows you to start the test at anytime and trim off unwanted data after the test has run. The DO reading at the reference point is shown at the top. The reference point cannot move closer than the minimum time to the end of the test.

The [SETTINGS] soft-key allows you to modify or input values for the Dilution factor. Changes to the Dilution factor are saved if you save the record again.

## SOUR

The 5100 uses the following formula to calculate the SOUR value:

$$\text{OUR} = \frac{\text{DO}_{\text{START}} - \text{DO}_{\text{END}}}{T_{\text{ELAPSED}}} \times \frac{3600 \text{ Sec}}{1 \text{ Hour}} \times \frac{\text{Total Volume}}{\text{Sample Volume}} = \text{mg/L/h}$$

Where:

$\text{DO}_{\text{START}}$  = Dissolved oxygen level at start of test

$\text{DO}_{\text{END}}$  = Dissolved oxygen level at end of test

$T_{\text{ELAPSED}}$  = Elapsed time of test in seconds

$\frac{\text{Total Volume}}{\text{Sample Volume}}$  = Dilution factor of sample (entered in setup screen as Sample/Total)

$$\text{SOUR} = \frac{\text{OUR}}{\text{Solids Weight}} = \text{mg/h/g} \quad (\text{mg O}_2 / \text{hour} / \text{g solids})$$

Where:

Solids Weight = Total Solids or Volatile Suspended Solids in g/L

From the Model 5100 Application mode menu press the [SOUR] (Specific Oxygen Uptake Rate) soft-key. The following screen will be displayed.

2.8 mg/h/g			SOUR
25.37°C	9.12 mg/L	SEND: off	0:00
START	SETUP	REVIEW	SEND



Press [SETUP] to change the SOUR parameters. The following screen shows the default parameters.

Sample / Total	1 / [ 1]	SOUR				
Min. Time	[ 1] min.					
Max. Time	[ 15] min.	[*]SOUR@20				
Min. Beginning DO	[ 5.00] mg/L	SEND: off				
Min. Ending DO	[ 2.00] mg/L					
Solids Weight	[ 1.000] g/L					
<table border="1" style="width: 100%; text-align: center;"> <tr> <td>UP</td> <td>DOWN</td> <td>DIGIT</td> <td>NEXT</td> </tr> </table>			UP	DOWN	DIGIT	NEXT
UP	DOWN	DIGIT	NEXT			

Use the [UP], [DOWN], [DIGIT] and [NEXT] soft-keys to change the following parameters as necessary:

- Sample / Total:** Enter the ratio of sample volume to total volume. For example, if you are diluting 1 to 10 (1 part sample plus 9 parts dilution water) then enter the number 10. This would be a 10-fold dilution.
- Min. Time:** Enter the minimum time (in minutes).
- Max. Time:** Enter the maximum time (in minutes). When the maximum time is reached, the test will end.
- Min. Beginning DO:** Enter the minimum level of DO allowed at the start of the test. If the DO falls below this level, the test will not start.
- Min. Ending DO:** Enter the minimum level of DO allowed during the test. If the DO level falls to this value, the test will end.
- Solids Weight:** Enter the Total Solids or Volatile Suspended Solids concentration of the sample in g/L. The maximum acceptable value is 31.999 g/L.
- SOUR@20:** This applies the calculation for temperature correction to 20°C according to the Farrell and Bhide equation as follows:
- $$SOUR_{20} = SOUR_T \times \bullet^{(20-T)}$$
- Where:
- = 1.05 above 20°C
  - 1.07 below 20°C
- This calculation is only valid for temperature ranges from 10° - 30°C
- SEND: on/off** This sets the RS232 status at the beginning of the test.

After the parameters have been set, press [ENTER] to save them and return to the SOUR menu.

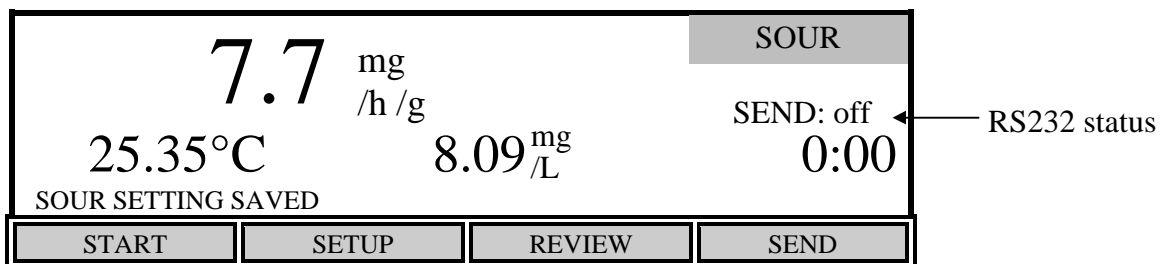

Once the parameters have been set, you are ready to begin. Place the probe in the prepared sample and make certain no air bubbles are trapped, then turn on the stirring and wait a few seconds for the temperature readings to stabilize.

NOTE: It is normal for the SOUR reading to oscillate for the first few seconds.

Press [START] to begin the SOUR measurement. The following screen shows the available soft-keys .

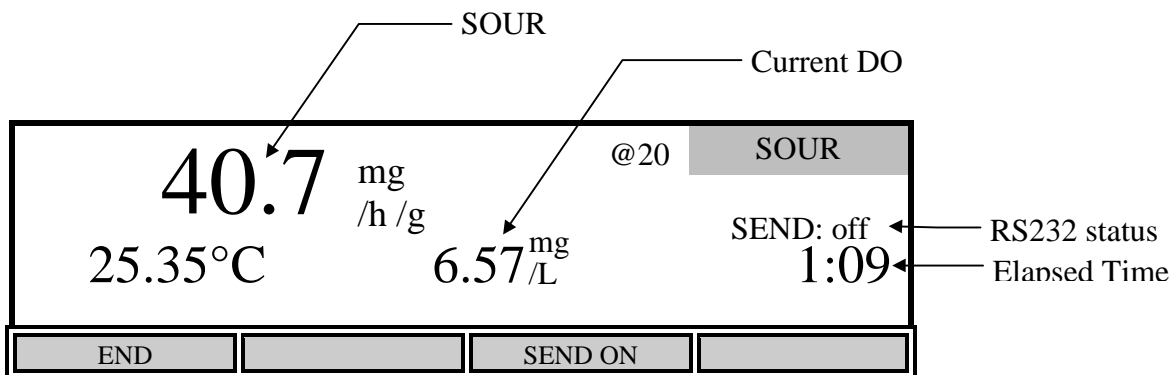

The SOUR value is displayed on the screen and is updated approximately once per second.

The [SEND ON/OFF] soft-key toggles the RS232 status. Press [SEND ON] if you want to send the readings to a computer or serial printer during the SOUR measurement. The RS232 status is displayed just above the elapsed time. During the SOUR measurement, data will be sent every 15 seconds until the SOUR measurement ends or the [SEND OFF] soft-key is pressed. The following is an example of the format:

NOTE: Once pressed, the [SEND ON] soft-key toggles and becomes a [SEND OFF] soft-key.

Second	mg/h/g	C	mg/L	10:32:36	09/21/98
1	.36	25.35	7.35		
15	92.57	25.35	6.99		
30	64.55	25.34	6.83		
45	42.54	25.35	6.71		
60	45.76	25.35	6.60	. . .	

If you want to stop the SOUR measurement before the maximum time or minimum ending DO (entered in SOUR setup) is reached, press the [END] soft-key. The final SOUR reading will be displayed on the screen.

<div style="font-size: 2em; font-weight: bold;">20.07</div> <div style="font-size: 1.2em;">mg /h /g</div>	<div style="font-size: 1.2em;">@20</div>	<div style="font-weight: bold;">SOUR</div>
<div style="font-size: 1.5em; font-weight: bold;">25.33</div> <div style="font-size: 1.2em;">°C</div>	<div style="font-size: 1.5em; font-weight: bold;">1.29</div> <div style="font-size: 1.2em;">mg /L</div>	<div style="font-size: 1.2em;">SEND on</div> <div style="font-size: 1.5em; font-weight: bold;">11:38</div>
PROCESS COMPLETE		
START	SETUP	STORE
SEND		

NOTE: The DO and temperature readings do not stop updating on the screen.

After the SOUR measurement has ended, the [SEND] soft-key can be used to send all of the DO values and the final SOUR to a computer or serial printer via the RS232 port. The format is as follows:

Time stamp: 10:32 AM

Date stamp: 09/21/98

Reference point: 30 (sec.)

Second mg/L

1	7.35
15	6.99
30	6.83
45	6.71
60	6.60 . . .

701 1.98

SOUR = 26.04 mg/h/g

SOUR@20 = 20.07 mg/h/g Tavg = 25.34 C

Dilution ratio: 1 / 1(Sample/Total)

Solids Weight : 1.000 g/L

NOTE: If you have run a SOUR measurement, but did not enter the appropriate sample dilution, you will get uncorrected results. However, after running the SOUR measurement, you may return to the SOUR setup screen, change the Sample / Total ratio or Solids Weight, then press [ENTER] to save the changes. The recalculated SOUR value will be displayed. Press [SEND] to send the new SOUR value to a computer or serial printer via the RS232 port.

If you want to save these values press the [STORE] soft-key. A record number will then show up under the REVIEW menu. If the record slot contains a set of data, an indicator saying FULL

will appear beside the test number. If the record slot does not contain a set of data, the indicator will say EMPTY.

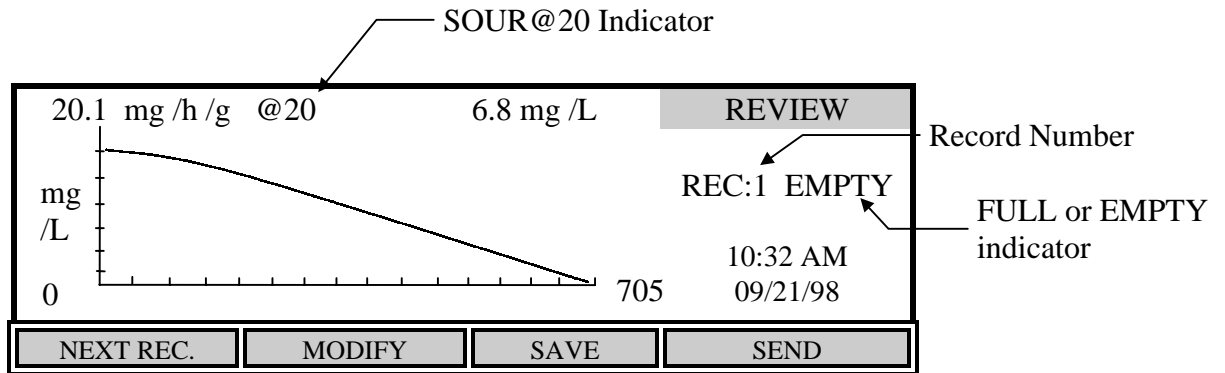

Press the [NEXT REC.] soft-key to change the record number to find an empty slot, or pick a slot to overwrite (you cannot delete results, you must overwrite). Press the [SAVE] soft-key to save the current test data into that slot. Once you have saved the data you can press the [MODIFY] soft-key to change the parameters of the test.

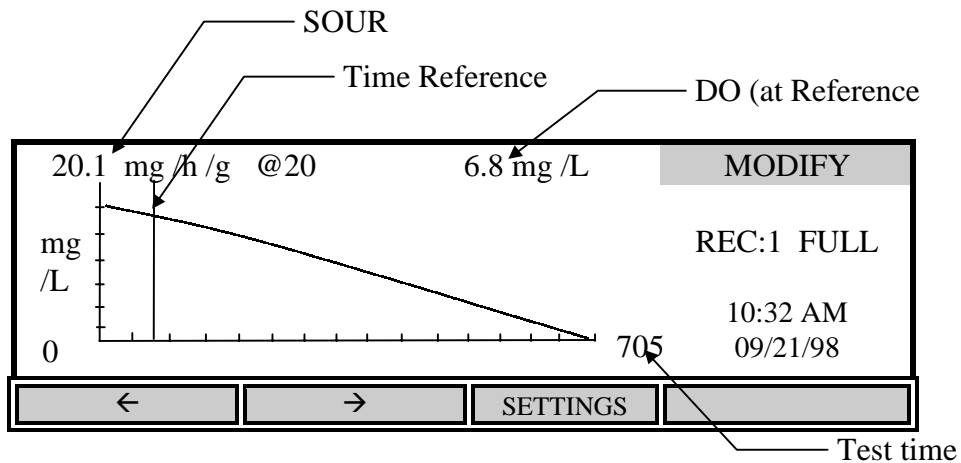

Press the ← or → soft-keys to move the start time reference point to an optimal place on the curve. The reference point is represented by a vertical line. Only data to the right of the reference point will be used to calculate the SOUR value. Moving this reference point allows you to start the test at anytime and trim off unwanted data after the test has run. The DO reading at the reference point is shown at the top. The reference point cannot move closer than the minimum time to the end of the test.

The [SETTINGS] soft-key allows you to modify or input values for the Dilution factor and Solids Weight. These changes are saved if you save the record again.

## Remote

From the Model 5000/5100 Application mode menu press the [REMOTE] soft-key. The following screen will be displayed.

	REMOTE		
STIR ON	96.4%	24.94	C
	ID: 1680	MODE	:0
SKIP	UP	DOWN	CONFIRM

The Remote mode is used in conjunction with YSI 5910 *BOD Analyst* software to greatly reduce the labor required for processing BODs and calculating BOD values.

Remote mode is also used to control the 5000/5100 via computer. This can be done using any standard communications program. See *Appendix D - Remote Command Language* for details.

### **RS232 Serial Port**

The RS232 serial port uses a standard DB9 connector. Use a straight serial cable (not a null modem) to connect the 5000/5100 to a computer serial port or a serial printer. See *15. Accessories and Replacement Parts* for the YSI item number. A 9 to 25 pin adapter will also be needed if the computer has a 25 pin serial port. Port settings are **9600** baud, **8** bits, Parity **None**, Stop bits **1**, and Flow Control set to **Xon / Xoff**.

### **Bar Code Reader**

The YSI Model 5015 bar code reader may be connected to the Model 5100 while in the Remote mode. This greatly improves data entry when entering sample ID numbers used with YSI *BOD Analyst* software. The YSI 5015 has a 6-Pin Mini DIN connector that connects to the rear of the 5100 (see *4.3 Rear Panel* for the location of the socket). The model 5000 does not support a bar code reader. Before using the 5015 bar code reader for the first time, it must be programmed as follows:

1. Plug the bar code reader into the connector labeled “BAR CODE” on the rear of the 5100.
2. Turn on the 5100.

In the *Laser Wedge 300 Bar Code Reader Programming Menus* booklet (the thinner booklet):

3. Turn to the page entitled “Bar Codes For Menus”, the last page in the booklet. Fold out the page so that the list of bar codes is scanable. Keep this page unfolded for later use as it contains the numbers and letters that will be used to program the bar code reader in the following steps.
4. Turn to the page entitled “Status Check”, the second to last page. Scan the DEFAULT ALL PARAMETERS bar code to load the factory default parameters. The bar code reader will beep to indicate a successful scan.

5. Turn to the page entitled “Terminal Selection”, the first page in the booklet.
  - 5.1. Scan the ENTER TERMINAL SELECTION bar code.
  - 5.2. Scan the 0 code on the “Bar codes for menus” page that you unfolded earlier. Hold the reader close to the page to prevent scanning more than one code at a time.
  - 5.3. Scan the 1 code on the “Bar codes for menus” page.
  - 5.4. Go back to the “Terminal Selection” page and scan the EXIT TERMINAL SELECTION bar code.
6. Turn to the page entitled “General III Control Parameters”, the sixth page in the booklet.
  - 6.1. Scan the ENTER GENERAL III SELECTIONS bar code.
  - 6.2. Scan the POSTAMBLE bar code.
  - 6.3. Scan the 0 code on the “Bar codes for menus” page that you unfolded earlier.
  - 6.4. Scan the D code.
  - 6.5. Scan the 0 code again.
  - 6.6. Scan the A code.
  - 6.7. Go back to the “General III Control Parameters” page and scan the EXIT GENERAL III SELECTIONS bar code.
7. Test the bar code reader configuration by selecting Remote mode from the Application menu of the 5100 and scanning a BOD bottle label. The bar code reader should beep, the 5100 should beep (if the beeper is enabled) and the 5100 should briefly display “BC” and the bar code number.

### ***External Computer Keyboard***

An external computer keyboard may be connected to the Model 5100 while in the Remote mode. This greatly improves data entry when entering sample ID numbers used with YSI *BOD Analyst* software (when a bar code reader is not available). The computer keyboard must be PC compatible and have a 6-Pin Mini DIN connector. A commercially available adapter may be used if necessary (5-Pin DIN to 6-Pin mini DIN). See 4.3 *Rear Panel* for the location of the socket. The model 5000 does not support an external computer keyboard.

## 8. Diagnostics

---

The YSI 5000/5100 has a diagnostic mode that is used primarily during troubleshooting. In Diagnosis mode you can view information from specific sensors, such as DO probe current, DO background current and pressure sensor offset. This information is useful when trying to isolate problems or monitor sensor conditions. When the 5000/5100 senses a problem, it displays an error code and message. Diagnosis mode can be used to determine when membrane/probe service is needed, before the instrument displays an error code. Refer to section *12. Troubleshooting* for additional information on error codes.

From the Main mode, press the [CALIBRATE] soft-key to enter Calibration mode, then press the [Diagnosis] soft-key to enter Diagnosis mode. The following screen will be displayed.

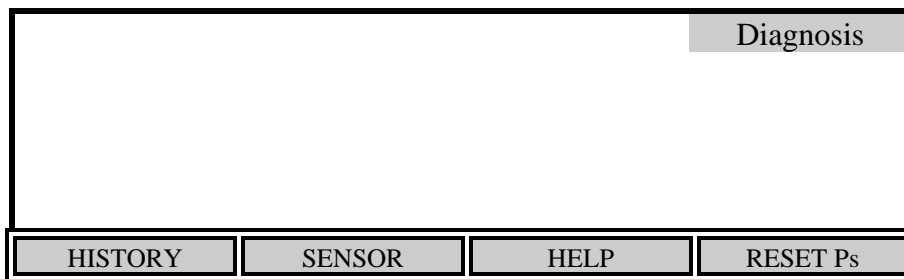

### History

Press the [HISTORY] soft-key to display the following information.

Date	Time	DO uA	%/uA	C	Diagnosis
02/01	14:12	16.8	5.98	21.9	
02/02	08:42	16.3	7.90	28.0	
02/05	09:55	17.0	6.42	23.0	
02/06	10:58	17.1	7.47	27.9	
02/07	13:08	16.9	6.43	22.8	
HISTORY	SENSOR	HELP	RESET Ps		

The History screen displays information about the last five DO calibrations. This information is useful for tracking the performance of the DO probe/membrane. The following parameters are displayed:

Date:           The date the calibration was performed.

- Time: The time the calibration was performed.
- DO uA: The dissolved oxygen calibration current in microamps. The calibration current (100% saturation at sea level) of an ideal probe using a 1 mil (standard) membrane is 13.7uA @ 20°C. If the probe current (100% saturation @ 20°C, 1 mil membrane) is greater than 17.0uA or lower than 8.0uA, the membrane/probe may need service. See *12. Troubleshooting, Error Codes, E3 and E4*.
- %/uA: The slope of the dissolved oxygen probe in percent per microamp corrected to 20°C. The slope of an ideal probe using a 1 mil membrane is 7.3 %/uA @ 20°C. If the probe slope (1 mil membrane) is greater than 12.6 %/uA or lower than 5.9 %/uA, the membrane/probe may need service. See *12. Troubleshooting, Error Codes, E3 and E4*.
- C: The temperature at the time of calibration in °C.

## Sensor

Press the [SENSOR] soft-key to display the following sensor diagnostics screen:

System Parameters		Sensor
Cal. Temperature	= 22.85 C	
Probe Slope	= 6.43 %/uA @20C	
Probe Offset	= 0.000 uA	
Probe Current	= 16.91 uA	
Pressure Offset	= 830 mbar	P = 981

- Cal. Temperature: The temperature at the time of the last calibration in °C.
- Probe Slope: The slope of the dissolved oxygen probe in percent per microamp corrected to 20°C. The slope of an ideal probe using a 1 mil membrane is 7.3%/uA @ 20°C. If the probe slope (1 mil membrane) is greater than 12.6 %/uA or lower than 5.9 %/uA, the membrane/probe may need service. See *12. Troubleshooting, Error Codes, E3 and E4*.
- Probe Offset: The zero offset current (background current) of the DO probe in microamps. The factory default value is 0.000 uA. This value will only change after a zero calibration is performed (see *6.2 Zero Calibration*). If this value is greater than 0.15uA (after a zero calibration) the membrane/probe may need service. See *12. Troubleshooting, Error Code E2*.
- Probe Current: The present (real time) DO probe current in microamps.



Pressure Offset: The offset of the barometer in millibars. This value will change whenever the barometer is calibrated. The normal range is 300 to 1300 mbar.

P: Current barometer reading in millibars.

Press [MODE] to return to the Diagnosis menu. Press [MODE] two more times to return to the Main menu.

### Reset Ps

The [RESET Ps] soft-key (Reset Parameters) is used to reset all instrument parameters to the factory default values. This is useful when the parameters have been changed or corrupted, such as when new software is loaded. Press the [RESET Ps] soft-key to display the following:

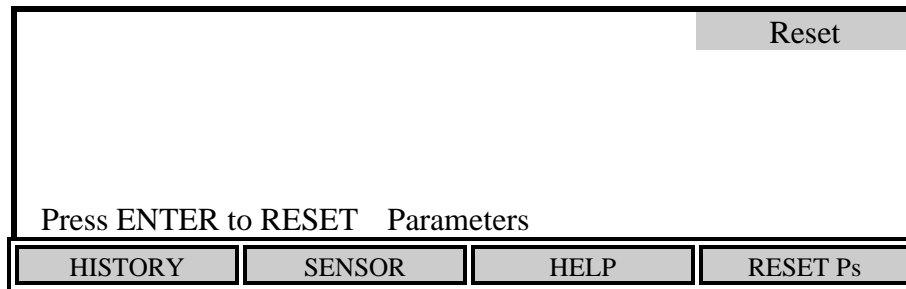

Press [ENTER] to confirm. All parameters, including calibration values, will be reset. If you do NOT wish to reset the parameters, press [MODE], instead of [ENTER], to return to the Diagnosis menu.

**WARNING: Resetting the instrument parameters to the factory default values will clear the barometer calibration/setting. You MUST recalibrate the barometer before performing an autocal. See 6.1 Dissolved Oxygen Calibration Barometer.**

## 9. Principles of Operation

---

YSI dissolved oxygen probes use membrane-covered, Clark-type polarographic sensors with built-in thermistors for temperature measurement and compensation. A thin permeable membrane, stretched over the sensor, isolates the sensor elements from the environment, but allows oxygen and certain other gases to enter. When a polarizing voltage is applied across the sensor, oxygen that has passed through the membrane reacts at the cathode, causing a current to flow. This current is read and interpreted by the YSI dissolved oxygen meter utilizing customized electronics and software to assure the highest possible accuracy and reliability.

Oxygen diffuses through the membrane at a rate proportional to the pressure difference across it. Since oxygen is rapidly consumed at the cathode, it can be assumed that the oxygen pressure inside the membrane is zero. Hence, the amount of oxygen diffusing through the membrane is proportional to the absolute pressure of oxygen outside the membrane. If the oxygen pressure increases, more oxygen diffuses through the membrane and more current flows through the sensor. A lower pressure results in less current.

## 10. Understanding Dissolved Oxygen Error Factors

---

The major sources of error in DO measurement are the accuracy of the instrument components, the accuracy of the probe, and the user's ability to calibrate the system precisely. Most errors can be reduced substantially by calibrating at DO levels and probe temperatures as close as possible to the expected measurement DO levels and temperatures.

In the following, individual sources of error and their ranges are listed. By calculating the root-mean-squared sum of these individual uncertainties (usually less than half the possible error), the user can estimate the probable error in any reading.

Note that all types of errors discussed are not necessarily present in a given situation. If salinity compensation is not used, for example, no salinity compensation error need be considered. If calibration is to a Winkler Titration sample, calibration errors are replaced by the Winkler uncertainty.

### Type 1 Errors: Instrument Components

a. Instrument accuracy:

$\pm 0.1\%$  plus 1 least significant digit.

### Type 2 Errors: Probe Accuracy

a. Probe background current error:

background factor  $\times (1 - a/b)c$

where **a** is the observed calibration value, **b** is the solubility of oxygen in fresh water at 760 mm Hg and at measurement temperature, and **c** is the measured DO value.

**a**, **b** and **c** are all measured in mg/L or all are measured in % air saturation.

Use the following table to determine the background factor:

probe temp. in °C	background factor (%)
0	2.3
10	1.5
20	1.0
30	0.8
40	0.6

b. Probe nonlinearity error:

$\pm 0.3\%$  of reading

- c. Temperature compensation error: The variation from nominal response to sample temperature is  $\pm 0.2\%$  of the DO reading per degree C of the temperature difference between the temperature of the sample and the temperature at which the probe was calibrated.

### **Type 3 Errors: Calibration**

- a. Sample temperature uncertainty error:

$\pm 1\%$  of reading

This error is approximately zero when using AUTO CAL, when manually calibrating in the % air saturation mode or when calibrating to a Winkler titration sample.

- b. Error due to barometric pressure uncertainty of 9 mmHg (12 mbar):

$\pm 1.2\%$  of reading

- c. Error due to altitude estimation uncertainty of 500 ft (152m):

$\pm 1.8\%$  of reading

This error is near zero when using AUTO CAL.

### **Error Calculation Example**

The example given assumes that air calibration is used. If the Winkler titration calibration method is used, type 3 errors are replaced by the uncertainty attributable to the overall Winkler determination. This example is for an extreme combination of conditions.

#### **Calibration conditions:**

method: air calibration  
temperature: 24°C  
altitude: 600 feet (183 meters)  
calibrated to: 8.24 mg/L

#### **Measurement conditions:**

temperature: 20°C  
reading: 7.26 mg/L  
mode: mg/L

## Calculation

Type	Description	Calculation	Error (mg/L)
1a	instrument accuracy	$(\pm 0.001 \times 7.26) + 0.01$	$\pm 0.017$
2a	probe background	$\pm 0.01 \times (1 - (8.24/9.09)) \times 7.26$	$\pm 0.007$
2b	probe nonlinearity	$\pm 0.003 \times 7.26$	$\pm 0.021$
2c	temp. compensation	$\pm (24 - 20) \times 0.002 \times 7.26$	$\pm 0.058$
3a	temp. uncertainty	$\pm 0.01 \times 7.26$	$\pm 0.073$
3b	pressure	$\pm 0.012 \times 7.26$	$\pm 0.087$

Probable error can be determined by an r.m.s. calculation:

$$\text{r.m.s. error} = [.017^2 + .007^2 + .021^2 + .058^2 + .073^2 + .087^2]^{1/2} = \pm 0.13 \text{ mg/L}$$

# 11. Maintenance

---

## Batteries

Low batteries are indicated on the display by “LOW BATT” as shown here.

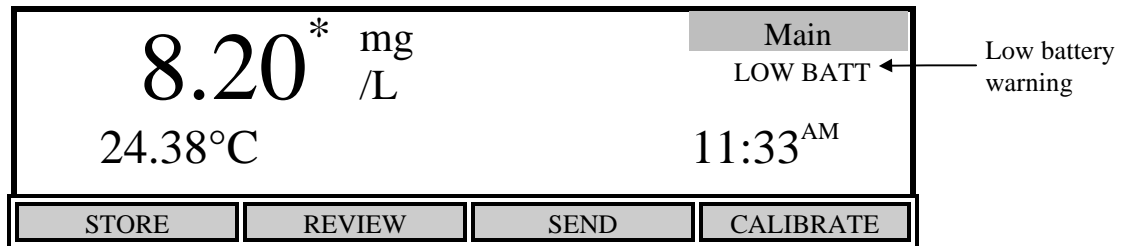

When this happens, replace the batteries with 4 fresh alkaline C-size batteries as soon as possible.

- Turn off the instrument.
- Turn the instrument over and slide the battery cover to the right (as indicated on the cover) and remove it.

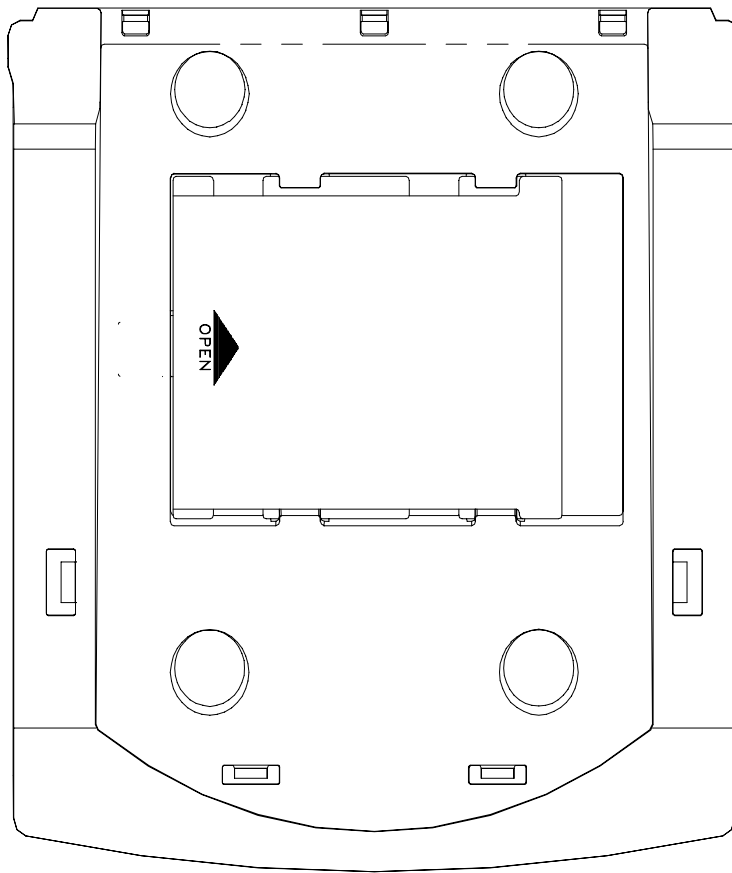

- Remove the old batteries and install fresh alkaline batteries. NOTE: Always observe the correct polarity when installing the batteries.
- Replace the battery cover and slide it to the left to lock it into place.

NOTE: The instrument parameters are stored in nonvolatile memory and will not be lost during battery replacement.

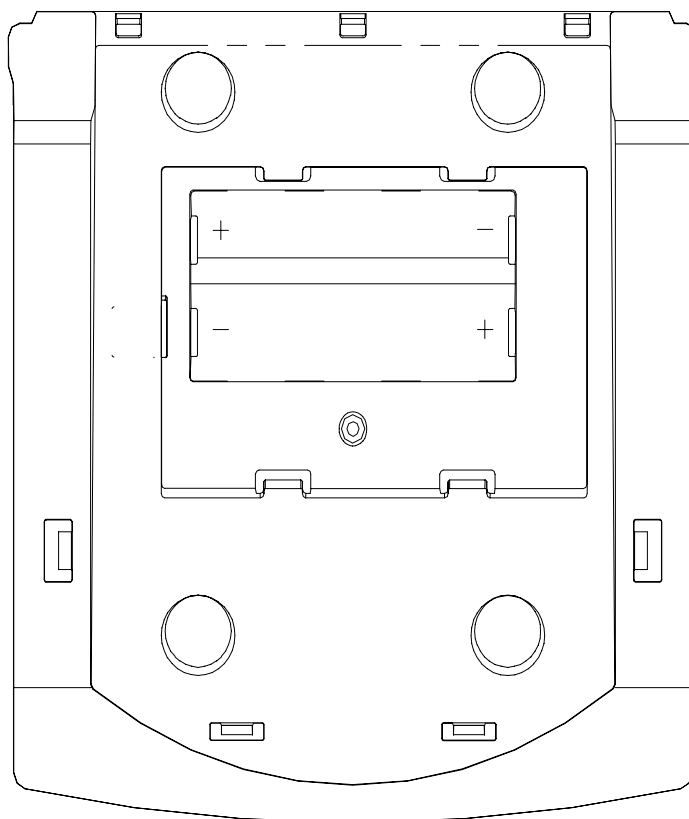

## 12. Troubleshooting

---

### Error Messages

The instrument performs a Power On Self Test each time it is turned on. The following error codes are provided to facilitate troubleshooting.

Code/Problem	Error	Possible Cause	Correction
	Blank Display	Dead/low batteries	Replace batteries or connect power supply
		5011 adapter improperly connected	Unplug 5011 from power supply connector
<b>E1:</b> Check Probe	Temperature under range	Connector improperly installed	Check probe connection
		Intermittent connection in cable or plug	Repair or replace
	Temperature over range	Electrical leakage in connector or cable	Repair or replace
		Faulty temperature sensor	Repair or replace
<b>E2:</b> Check Membrane	High Background current (DO)	Insufficient warm-up time	See Calibration
		Incorrect probe zeroing procedure	See Zero Calibration
		Probe needs servicing	See probe instructions
		Probe malfunction	Repair or replace
<b>E3:</b> Check Membrane	DO Low current	Insufficient electrolyte	See probe instructions
		Contaminated electrodes or fouled membrane	See probe instructions
		Membrane too thick	Try another membrane
		High resistance in probe connection	Repair or replace



Code/Problem	Error	Possible Cause	Correction
<b>E4:</b> Check Membrane	DO High Current	Membrane too thin	Try another membrane
		Electrodes need resurfacing	Repair or replace
		Internal leakage in probe or cable connector	Repair or replace
		Short circuit in probe or cable	Repair or replace
<b>E5:</b> Check Membrane	DO unstable	Membrane damaged	Replace membrane
		Probe needs servicing	See probe instructions
		Connector improperly installed	Check probe connection
		Intermittent connection in cable or plug	Repair or replace
ERROR:	DO reading < min. DO	Probe malfunction	Repair or replace
		The DO reading at the start of the OUR or SOUR measurement is below the “minimum beginning DO” entered in the OUR or SOUR setup. See 7.2 <i>Application Mode, OUR, or SOUR</i> .	
ERROR:	Illegal value	The value entered is outside the acceptable range.	Enter the correct value
ERROR:	RTC defect control register	Real time clock failure	Return for repair
ERROR:	Init. Logger failed	Logger initialization failed	Return for repair

## 13. Warranty & Repair

---

YSI 5000 Series Dissolved Oxygen Instruments are warranted for two years from date of purchase by the end user against defects in materials and workmanship. YSI dissolved oxygen probes and cables are warranted for one year from date of purchase by the end user against defects in material and workmanship. Within the warranty period, YSI will repair or replace, at its sole discretion, free of charge, any product that YSI determines to be covered by this warranty.

To exercise this warranty, write or call your local YSI representative, or contact YSI Customer Service in Yellow Springs, Ohio. Send the product and proof of purchase, transportation prepaid, to the Authorized Service Center selected by YSI. Repair or replacement will be made and the product returned, transportation prepaid. Repaired or replaced products are warranted for the balance of the original warranty period, or at least 90 days from date of repair or replacement.

### Limitation of Warranty

This Warranty does not apply to any YSI product damage or failure caused by (i) failure to install, operate or use the product in accordance with YSI's written instructions, (ii) abuse or misuse of the product, (iii) failure to maintain the product in accordance with YSI's written instructions or standard industry procedure, (iv) any improper repairs to the product, (v) use by you of defective or improper components or parts in servicing or repairing the product, or (vi) modification of the product in any way not expressly authorized by YSI.

**THIS WARRANTY IS IN LIEU OF ALL OTHER WARRANTIES, EXPRESSED OR IMPLIED, INCLUDING ANY WARRANTY OF MERCHANTABILITY OR FITNESS FOR A PARTICULAR PURPOSE. YSI'S LIABILITY UNDER THIS WARRANTY IS LIMITED TO REPAIR OR REPLACEMENT OF THE PRODUCT, AND THIS SHALL BE YOUR SOLE AND EXCLUSIVE REMEDY FOR ANY DEFECTIVE PRODUCT COVERED BY THIS WARRANTY. IN NO EVENT SHALL YSI BE LIABLE FOR ANY SPECIAL, INDIRECT, INCIDENTAL OR CONSEQUENTIAL DAMAGES RESULTING FROM ANY DEFECTIVE PRODUCT COVERED BY THIS WARRANTY.**

### YSI Factory Service Centers

#### United States

YSI Incorporated • Repair Center • 1725 Brannum Lane • Yellow Springs, OH • 45387 • Phone: 937 767-7241 • Fax: 937 767-9353  
Endeco/YSI Inc. • 13 Atlantis Drive • Marion, MA • 02738 • Phone: 508 748-0366 • Fax: 508 748-2543

#### Europe

YSI LTD • Lynchford House • Lynchford Lane • Farnborough, Hampshire • GU14 GLT • Phone: 441 252 514711 • Fax: 441 252 511855

### YSI Authorized Service Centers

#### California

Eviroservices & Repair • 1110 Burnett Avenue, Suite D • Concord, CA • 94520 • Phone: 510 609-1088 • Fax: 510 674-8655  
Fisher Scientific ISD • 2822 Walnut Avenue, Suite E • Tustin, CA • 92681 • Phone: 800 395-5442

#### Florida

Aquatic Eco Systems, Inc. • 1767 Benbow Court • Apopka, FL • 32703 • Phone: 407 886-3939 • Fax: 407 886-6787

#### Georgia

Fisher Scientific ISD • 2775 Horizon Ridge Court • Suwanee, GA • 30174 • Phone: 800 395-5442

#### Illinois

Fisher • 1600 West Gleenlake Avenue • Itasca, Ill • 60143 • Phone: 800 395-5442

#### Maine

Q. C. Services • P.O. Box 68 • Harrison, ME • 04040 • Phone: 207 583-2980

#### Mississippi

Aquacenter • 166 Seven Oaks Road • Leland, MS • 38756 • Phone: 601 378-2861 • Fax: 601 378-2862

#### New Jersey

Fisher Scientific ISD • 52 Fadem Road • Springfield, NJ • 07081 • Phone: 800 395-5442

#### Oregon

Q. C. Services • P.O. Box 14831 • Portland, OR • 97293 • Phone: 503 236-2712

#### Pennsylvania

Fisher Scientific ISD • 585 Alpa Drive • Blawnox, PA • 15238 • Phone: 800 395-5442

## Cleaning Instructions

**NOTE: Before they can be serviced, equipment exposed to biological, radioactive, or toxic materials must be cleaned and disinfected.** Biological contamination is presumed for any instrument, probe, or other device that has been used with body fluids or tissues, or with waste water. Radioactive contamination is presumed for any instrument, probe or other device that has been used near any radioactive source.

If an instrument, probe, or other part is returned or presented for service without a Cleaning Certificate, and if in our opinion it represents a potential biological or radioactive hazard, our service personnel reserve the right to withhold service until appropriate cleaning, decontamination, and certification has been completed. We will contact the sender for instructions as to the disposition of the equipment. Disposition costs will be the responsibility of the sender.

When service is required, either at the user's facility or at YSI, the following steps must be taken to insure the safety of our service personnel.

1. In a manner appropriate to each device, decontaminate all exposed surfaces, including any containers. 70% isopropyl alcohol or a solution of 1/4 cup bleach to 1 gallon tap water are suitable for most disinfecting. Instruments used with waste water may be disinfected with .5% Lysol if this is more convenient to the user.
2. The user shall take normal precautions to prevent radioactive contamination and must use appropriate decontamination procedures should exposure occur.
3. If exposure has occurred, the customer must certify that decontamination has been accomplished and that no radioactivity is detectable by survey equipment.
4. Any product being returned to the YSI Repair Center, should be packed securely to prevent damage.
5. Cleaning must be completed and certified on any product before returning it to YSI.

## Packing Instructions

1. Clean and decontaminate items to insure the safety of the handler.
2. Complete and include the Cleaning Certificate.
3. Place the product in a plastic bag to keep out dirt and packing material.
4. Use a large carton, preferably the original, and surround the product completely with packing material.
5. Insure for the replacement value of the product.

### Cleaning Certificate

Organization \_\_\_\_\_

Department \_\_\_\_\_

Address \_\_\_\_\_

City \_\_\_\_\_ State \_\_\_\_\_ Zip \_\_\_\_\_

Country \_\_\_\_\_ Phone \_\_\_\_\_

Model No. of Device \_\_\_\_\_ Lot Number \_\_\_\_\_

Contaminant (if known) \_\_\_\_\_

Cleaning Agent(s) used \_\_\_\_\_

Radioactive Decontamination Certified?

(Answer only if there has been radioactive exposure)

\_\_\_ Yes \_\_\_ No

Cleaning Certified By \_\_\_\_\_

Name

Date

## 14. Required Notice

---

This equipment generates and uses radio frequency energy and if not installed and used properly, may cause interference to radio and television reception. There is no guarantee that interference will not occur in a particular installation. If this equipment does cause interference to radio or television reception, which can be determined by turning the equipment off and on, the user is encouraged to try to correct the interference by one or more of the following measures:

- Reorient the receiving antenna
- Relocate the computer with respect to the receiver
- Move the computer away from the receiver
- Plug the computer into a different outlet so that the computer and receiver are on different branch circuits.

If necessary, the user should consult the dealer or an experienced radio/television technician for additional suggestions. The user may find the following booklet, prepared by the Federal Communications Commission, helpful: "How to Identify and Resolve Radio-TV Interference Problems." This booklet is available from the U.S. Government Printing Office, Washington, D.C. 20402, Stock No. 0004-000-00345-4.

## 15. Accessories and Replacement Parts

YSI Item #	Description	Model / Comments
005117	Power Supply, 115 VAC, 800 ma	5000, 5100
051051	Power Supply, 230 VAC, 500 ma	5000, 5100
050101	Overlay, Window, 5000	5000
051015	Overlay, Window, 5100	5100
051016	Overlay, Keypad	5000, 5100
051009	Window	5000, 5100
050048	Board Assy, PC, Main	5000
051055	Board Assy, PC, Main	5100
111021	Display Assy	5000, 5100
051023	Door, Battery	5000, 5100
111015*	Case Assy, Upper	5000
111007*	Case Assy, Upper	5100
111017	Case Assy, Lower, w/battery door	5000, 5100
051043	Foot, Rubber, Self-Stick	5000, 5100
051034	Terminal, Battery, Push-On	5000, 5100
032061	Gasket, Connector, Probe/Bar Code	5000, 5100 (2 required)
032063	Gasket, Connector, Power Supply	5000, 5100
032064	Gasket, Connector, RS232	5000, 5100
051025	Standoff, .25, Snap-In	5000, 5100 / Retain Display
003228*	Extension, Switch	5000, 5100
051029	Operations Manual	5000, 5100
051042	Service Manual	5000, 5100
052021	RS232 Cable, DB9	5000, 5100
YSI Model 5015	Bar code reader	5100 only
YSI Model 5011	Probe adapter (converts from probe MS connector to meter DIN)	5000, 5100

\* Instruments with serial numbers starting with 96L or lower, contact YSI.

## 16. Appendix A - Oxygen Solubility Table

---

**Solubility of Oxygen in mg/l in Water Exposed to Water-Saturated Air at 760 mm Hg Pressure as a function of temperature.**

**Salinity = Measure of quantity of dissolved salts in water.**

**Chlorinity = Measure of chloride content, by mass, of water.**

$$S(\text{‰}) = 1.80655 \times \text{Chlorinity} (\text{‰})$$

Temp °C	Chlorinity:0 Salinity:0	5.0 ppt 9.0 ppt	10.0 ppt 18.1 ppt	15.0 ppt 27.1 ppt	20.0 ppt 36.1 ppt	25.0 ppt 45.2 ppt
0.0	14.62	13.73	12.89	12.10	11.36	10.66
1.0	14.22	13.36	12.55	11.78	11.07	10.39
2.0	13.83	13.00	12.22	11.48	10.79	10.14
3.0	13.46	12.66	11.91	11.20	10.53	9.90
4.0	13.11	12.34	11.61	10.92	10.27	9.66
5.0	12.77	12.02	11.32	10.66	10.03	9.44
6.0	12.45	11.73	11.05	10.40	9.80	9.23
7.0	12.14	11.44	10.78	10.16	9.58	9.02
8.0	11.84	11.17	10.53	9.93	9.36	8.83
9.0	11.56	10.91	10.29	9.71	9.16	8.64
10.0	11.29	10.66	10.06	9.49	8.96	8.45
11.0	11.03	10.42	9.84	9.29	8.77	8.28
12.0	10.78	10.18	9.62	9.09	8.59	8.11
13.0	10.54	9.96	9.42	8.90	8.41	7.95
14.0	10.31	9.75	9.22	8.72	8.24	7.79
15.0	10.08	9.54	9.03	8.54	8.08	7.64
16.0	9.87	9.34	8.84	8.37	7.92	7.50
17.0	9.67	9.15	8.67	8.21	7.77	7.36
18.0	9.47	8.97	8.50	8.05	7.62	7.22
19.0	9.28	8.79	8.33	7.90	7.48	7.09
20.0	9.09	8.62	8.17	7.75	7.35	6.96

<b>Temp °C</b>	<b>Chlorinity:0 Salinity:0</b>	<b>5.0 ppt 9.0 ppt</b>	<b>10.0 ppt 18.1 ppt</b>	<b>15.0 ppt 27.1 ppt</b>	<b>20.0 ppt 36.1 ppt</b>	<b>25.0 ppt 45.2 ppt</b>
21.0	8.92	8.46	8.02	7.61	7.21	6.84
22.0	8.74	8.30	7.87	7.47	7.09	6.72
23.0	8.58	8.14	7.73	7.34	6.96	6.61
24.0	8.42	7.99	7.59	7.21	6.84	6.50
25.0	8.26	7.85	7.46	7.08	6.72	6.39
26.0	8.11	7.71	7.33	6.96	6.62	6.28
27.0	7.97	7.58	7.20	6.85	6.51	6.18
28.0	7.83	7.44	7.08	6.73	6.40	6.09
29.0	7.69	7.32	6.96	6.62	6.30	5.99
30.0	7.56	7.19	6.85	6.51	6.20	5.90
31.0	7.43	7.07	6.73	6.41	6.10	5.81
32.0	7.31	6.96	6.62	6.31	6.01	5.72
33.0	7.18	6.84	6.52	6.21	5.91	5.63
34.0	7.07	6.73	6.42	6.11	5.82	5.55
35.0	6.95	6.62	6.31	6.02	5.73	5.46
36.0	6.84	3.52	6.22	5.93	5.65	5.38
37.0	6.73	6.42	6.12	5.84	5.56	5.31
38.0	6.62	6.32	6.03	5.75	5.48	5.23
39.0	6.52	6.22	5.98	5.66	5.40	5.15
40.0	6.41	6.12	5.84	5.58	5.32	5.08
41.0	6.31	6.03	5.75	5.49	5.24	5.01
42.0	6.21	5.93	5.67	5.41	5.17	4.93
43.0	6.12	5.84	5.58	5.33	5.09	4.86
44.0	6.02	5.75	5.50	5.25	5.02	4.79
45.0	5.93	5.67	5.41	5.17	4.94	4.72



## 17. Appendix B - Pressures and Altitudes

---

### Calibration Values for Various Atmospheric Pressures and Altitudes

inches Hg	PRESSURE		ALTITUDE		CALIBRATION VALUE (%)
	mm Hg	millibars	Feet	meters	
30.23	768	1023	-276	-84	101
29.92	760	1013	0	0	100
29.61	752	1003	278	85	99
29.33	745	993	558	170	98
29.02	737	983	841	256	97
28.74	730	973	1126	343	96
28.43	722	963	1413	431	95
28.11	714	952	1703	519	94
27.83	707	942	1995	608	93
27.52	699	932	2290	698	92
27.24	692	922	2587	789	91
26.93	684	912	2887	880	90
26.61	676	902	3190	972	89
26.34	669	892	3496	1066	88
26.02	661	882	3804	1160	87
25.75	654	871	4115	1254	86
25.43	646	861	4430	1350	85
25.12	638	851	4747	1447	84
24.84	631	841	5067	1544	83
24.53	623	831	5391	1643	82
24.25	616	821	5717	1743	81
23.94	608	811	6047	1843	80
23.62	600	800	6381	1945	79
23.35	593	790	6717	2047	78
23.03	585	780	7058	2151	77
22.76	578	770	7401	2256	76
22.44	570	760	7749	2362	75
22.13	562	750	8100	2469	74
21.85	555	740	8455	2577	73
21.54	547	730	8815	2687	72
21.26	540	719	9178	2797	71
20.94	532	709	9545	2909	70
20.63	524	699	9917	3023	69
20.35	517	689	10293	3137	68
20.04	509	679	10673	3253	67
19.76	502	669	11058	3371	66

## 18. Appendix C - Conversion Factors

TO CONVERT FROM	TO	EQUATION
Feet	Meters	Multiply by 0.3048
Meters	Feet	Multiply by 3.2808399
Degrees Celsius	Degrees Fahrenheit	$9/5 \times (^{\circ}\text{C}) + 32$
Degrees Fahrenheit	Degrees Celsius	$5/9 \times (^{\circ}\text{F} - 32)$
Milligrams per liter (mg/l)	Parts per million (ppm)	Multiply by 1

### Conversion Factors for Common Units of Pressure

	kilo Pascals	mm Hg	millibars	inches H <sub>2</sub> O	PSI	inches Hg
<b>1 atm</b>	101.325	760.000	1013.25	406.795	14.6960	29.921
<b>1 kiloPascal</b>	1.00000	7.50062	10.0000	4.01475	0.145038	0.2953
<b>1 mmHg</b>	0.133322	1.00000	1.33322	0.535257	0.0193368	0.03937
<b>1 millibar</b>	0.100000	0.750062	1.00000	0.401475	0.0145038	0.02953
<b>1 inch H<sub>2</sub>O</b>	0.249081	1.86826	2.49081	1.00000	.0361	0.07355
<b>1 PSI</b>	6.89473	51.7148	68.9473	27.6807	1.00000	2.0360
<b>1 inch Hg</b>	3.38642	25.4002	33.8642	13.5956	0.49116	1.00000
<b>1 hectoPascal</b>	0.100000	0.75006	1.00000	0.401475	0.0145038	0.02953
<b>1 cm H<sub>2</sub>O</b>	0.09806	0.7355	$9.8 \times 10^{-7}$	0.3937	0.014223	0.02896

## 19. Appendix D - Remote Command Language

---

Remote commands and data output are available only when the instrument is in the Remote mode.

### **Command Format:**

<Prefix><Command Type><Parameter><Suffix>

### **Prefix:**

The prefix consists of the two character sequence <ESC>&. In HEX this is 1B 26.

### **Suffix:**

The suffix consists of the two character sequence <CR><LF>. In HEX this is 0D 0A.

### **Command Types and Parameters:**

Command types are arranged into two groups, immediate and automatic.

The Display command controls the display of remote messages.

Command	type	parameter	description
D	0	string	echoes the string to the first line of the display
D	1	string	echoes the string to the second line of the display
D	2	none	Clear display lines 0 and 1
D	3	0	Set display update flag line 0
D	3	1	Set display update flag line 1

The ouTput mode command controls how data flow is controlled. A bar code scan in T1 or T2 mode will cause a line of output, just as if the T command had been received.

Command	type	parameter	description
T	0	none	Continuous data output
T	1	none	One line of data output in response
T	2	none	One line after stable reading

The P commands are for requesting system information.

Command	type	parameter	description
P	0	none	Request calibration parameters
P	1	none	Request solubility table dump
P	2	none	Request raw A/D
P	3	none	Request System status

The system Setup commands.

Command	type	parameter	description
S	0	nn.n	set salinity to nn.n
S	1	hh:mm:ss	set time of day, 24 hour clock
S	2	mm/dd/yy	set calendar
S	4	1	emit an audio beep from beeper
S	5	0	DO. calibration and display mode is %
S	5	3	DO. calibration and display mode is mg/L
S	7	nnn.n	Set DO. calibration value
S	9	0	Disable audio feedback
S	9	1	Enable audio feedback

Software Version requests:

Command	type	parameter	description
V	0	none	request software version
V	1	none	request version date
V	2	none	request model number

Reset command:

Command	type	parameter	description
E	none	none	reset system to defaults



*YSI incorporated*

1725 Brannum Lane  
Yellow Springs, Ohio 45387 USA  
937 767-7241 • 800 765-4974 • Fax 937 767-9353  
Info@ysi.com • www.YSI.com  
© 1998 YSI Incorporated

051029  
A51029G  
September 99