



Level



Pressure



Flow



Temperature

Liquid
Analysis

Registration

Systems
Components

Services



Solutions

Technical Information

Indumax CLS50/CLS50D

Inductive conductivity sensor for standard, hazardous and high-temperature applications, analog or digital with Memosens protocol



Application

Indumax CLS50/CLS50D conductivity sensors are especially suitable for application in the chemical industry and process engineering. The six-decade measuring range and the high chemical resistance of the materials in contact with medium (PFA or PEEK) permit to use this sensor in a number of various applications, e.g.:

- Concentration measurement of acids and bases
- Quality monitoring of chemical products in tanks and pipes
- Phase separation of product/product mixtures

Digital CLS50D sensors are used with the controller Liquiline CM442. Analog CLS50 sensors are used with the transmitters Liquiline CM42, Liquisys CLM223/253 or Mycom CLM153.

Your benefits

- High durability
 - High chemical resistance thanks to PFA coating
 - PEEK version for high temperatures up to 180 °C (356 °F)
- Low risk of soiling
 - Dirt-repellent PFA surface
 - Large sensor opening
- Easy installation
 - Can be installed in T-pieces \geq DN 80 with the outgoing diameter reduced to \geq DN 50
 - Total cable length up to 55 m (180 ft)
- Wide measuring range from 2 μ S/cm to 2000 mS/cm
- Integrated, coated Pt 100 temperature sensor, error class A
- Ex approval EEx ia IIC T6/T4

Function and system design

Measuring principle

Inductive conductivity measurement

A generator (1) generates an alternating magnetic field in the primary coil (2) which induces a current in the medium (3). The strength of the induced current depends on the conductivity and thus the ion concentration of the medium. The current flow in the medium generates another magnetic field in the secondary coil (4). The resulting current induced in the coil is measured by the receiver (5) and processed to determine the conductivity.

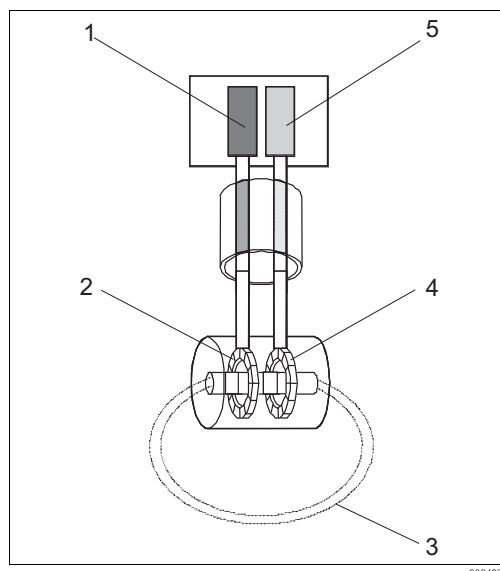

Inductive conductivity measurement

- 1 Generator
- 2 Primary coil
- 3 Current flow in the medium
- 4 Secondary coil
- 5 Receiver

Benefits of inductive conductivity measurement

- No electrodes, therefore no polarization
- Accurate measurement in media or solutions with a high soiling degree and a tendency to deposition
- Complete galvanic separation of measurement and medium

Important properties

■ Wide measuring range

The sensor's measuring range comprises six decades, from 2 $\mu\text{S}/\text{cm}$ to 2000 mS/cm .

■ Durability

The materials in contact with medium (PEEK, PFA) feature a very high chemical resistance. In addition, the PEEK version is suitable for application at high temperatures of up to 180 °C (356 °F).

■ Low risk of soiling

Thanks to its large opening, the sensor is not susceptible to soiling. The PFA version requires even less cleaning thanks to its dirt-repellent surface.

Advantages of digital sensors with Memosens protocol

Digital sensors are able to store the following system data in the sensor:

- Manufacturing data
 - Serial number
 - Order code
 - Date of manufacture
- Calibration data
 - Calibration date
 - Cell constant
 - Change in cell constant
 - Number of calibrations
 - Serial number of the transmitter used for the last calibration
- Application data
 - Temperature application range
 - Conductivity application range
 - Date of first commissioning
 - Maximum temperature value
 - Operating hours at high temperatures

Measuring system

CLS50D

A complete measuring system comprises:

- a CLS50D conductivity sensor with fixed cable
- a transmitter, e.g. Liquiline CM44x

Optional:

- Weather protection cover for the field installation of the transmitter
- Assembly for sensor installation in tanks or in pipework, e.g. CLA111

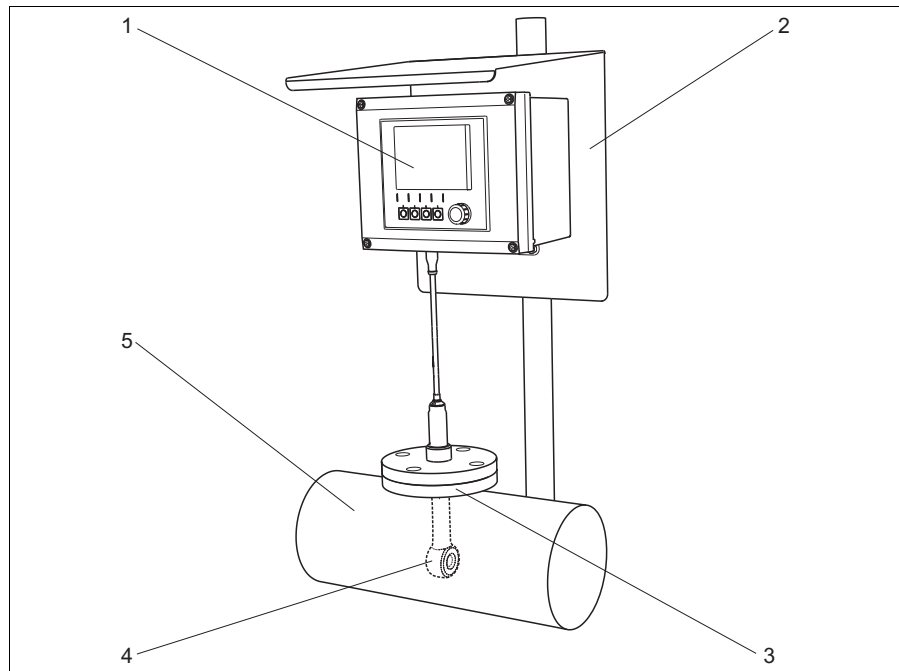

a0012990

Example of a measuring system

- 1 *Liquiline CM44x transmitter*
- 2 *Weather protection cover*
- 3 *Pipe socket for flange DN50 PN/6*
- 4 *Sensor CLS50D, flange version DN50 PN/6, fixed cable with M12 plug*

CLS50

A complete measuring system comprises:

- a CLS50 conductivity sensor with fixed cable
- a transmitter, e.g. Liquiline CM42

Optional:

- Weather protection cover for the field installation of the transmitter
- Assembly for sensor installation in tanks or in pipework, e.g. CLA111

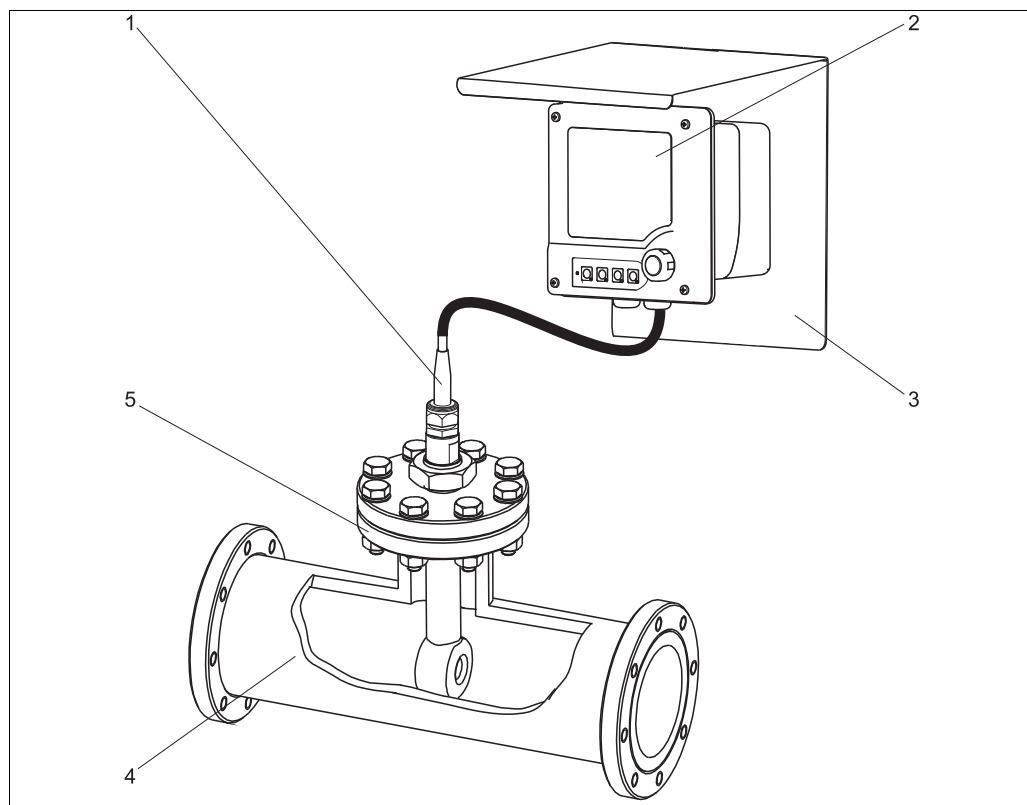

Example of a measuring system

- 1 Indumax CLS50
- 2 Liquiline CM42 transmitter
- 3 Weather protection cover
- 4 Pipework
- 5 Pipe socket

Input

Measured variable	<ul style="list-style-type: none"> ■ Conductivity ■ Temperature
Cell constant	$k = 1.98 \text{ cm}^{-1}$
Measuring frequency	2 kHz
Measuring range	Conductivity: 2 $\mu\text{S/cm}$ to 2000 mS/cm (uncompensated) Temperature: -20 to +180 $^{\circ}\text{C}$ (-4 to +350 $^{\circ}\text{F}$)
Temperature measurement	Pt 100 (class A acc. to IEC 60751)

Wiring

Cable specification

The sensor is supplied with a fixed cable. The connection to the transmitter can be extended using the CYK81 (CLS50D) or the CLK5 (CLS50) special measuring cable.

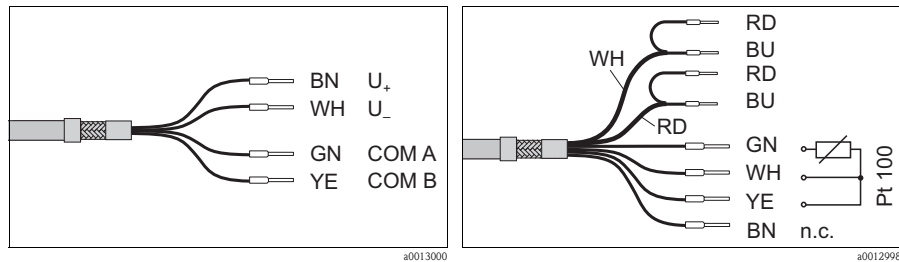

CYK81 for cable extension for CLS50D
 – max. total cable length: 100 m (330 ft)

CLK5 for cable extension for CLS50
 – max. total cable length: 55 m (180 ft)

Note!

Please note that the residual coupling increases when the cable is extended.

Performance characteristics

Maximum measured error

- **-20 to 100 °C (-4 to 212 °F):**
 $\pm(5 \mu\text{S}/\text{cm} + 0.5 \% \text{ of the measured value})$
- **> 100 °C (212 °F):**
 $\pm(10 \mu\text{S}/\text{cm} + 0.5 \% \text{ of the measured value})$

Temperature response time

- **PEEK versions:**
 approx. 7 min
- **PFA versions:**
 approx. 11 min

Installation conditions

Installation position

Install the sensor in such a way that the sensor opening is oriented in the flow direction of the medium. The sensor head must be completely immersed in the medium.

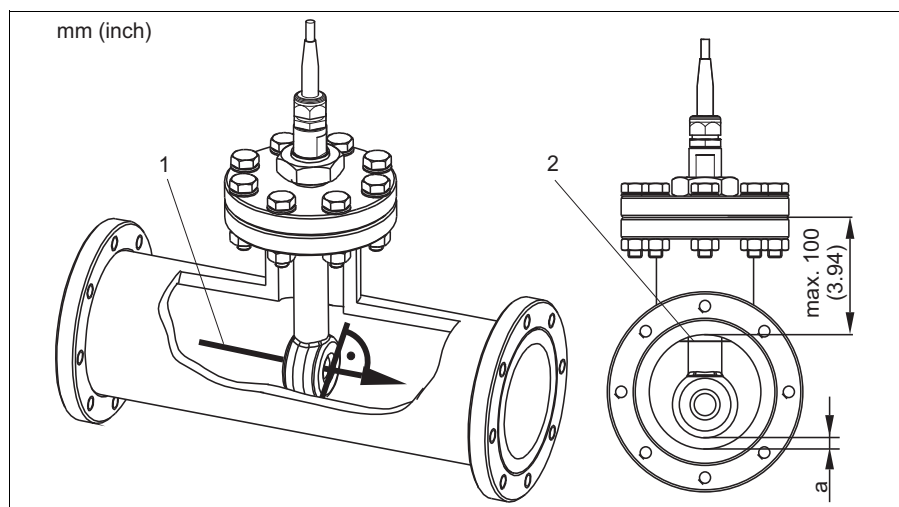

Installation position of the sensor

- 1 Flow direction of medium
- 2 Minimum water level in the pipe
- a Sensor distance from the pipe wall

a0007035

Installation factor

In narrow installation conditions, the conductivity measurement is affected by the pipe walls. This effect is compensated by the so-called installation factor. The transmitter corrects the cell constant by multiplication with the installation factor.

The value of the installation factor depends on the diameter and the conductivity of the pipe as well as the sensor's distance from the wall.

If the distance from the wall is sufficient ($a > 15$ mm (0.59"), from DN 80), it is not necessary to consider the installation factor ($f = 1.00$).

If the distance from the wall is smaller, the installation factor increases in case of electrically insulating pipes ($f > 1$) and decreases in case of electrically conductive pipes ($f < 1$).

The installation factor can be measured using calibration solutions or it can be approximately determined from the following diagram.

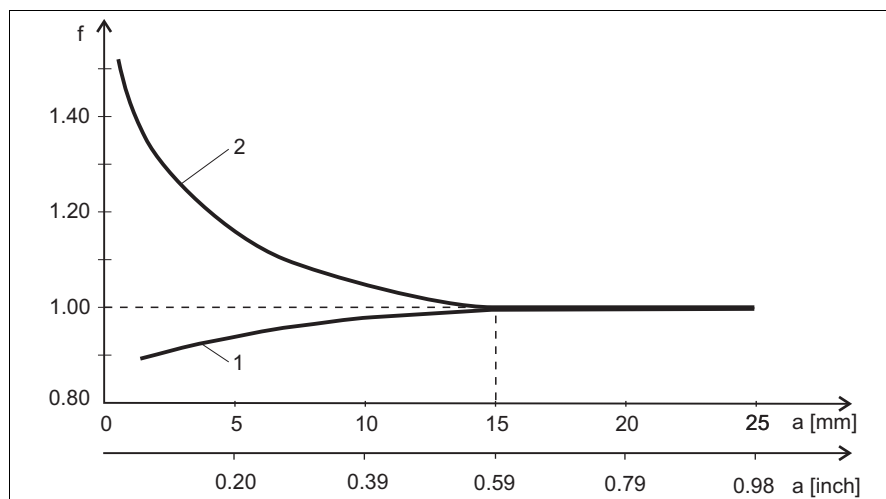

Relationship between installation factor f and distance from wall a

1 Electrically conductive pipe wall

2 Insulating pipe wall

a0005441

Air set**CLS50**

To compensate residual coupling in the cable and between the two sensor coils, you must perform a zero calibration in air ("air set") before installing the sensor.

For further information, refer to the Operating Instructions of your transmitter.

CLS50D

The digital sensor is already adjusted at the factory, an on-side compensation is not necessary.

Installation of sensors with flange

The sensor is suitable for installation in T-pieces \geq DN 80 with the outgoing diameter reduced to \geq DN 50.

Warning!

Danger of injuries by leaking medium

- Tighten the nut with a torque of at least 20 Nm.
- To avoid leakages, regularly check the tightness of the nut.

Flange, not in contact with medium

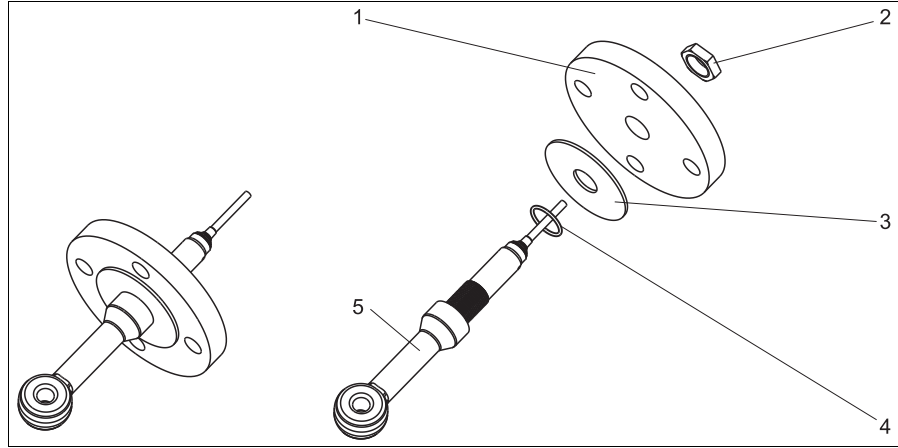

Fixed flange, not in contact with medium (order option "process connection": 5, 6, 7)

- | | | | |
|---|--------------------------|---|--------|
| 1 | Flange (stainless steel) | 4 | O-ring |
| 2 | Nut | 5 | Sensor |
| 3 | Sealing disk (Gylon®) | | |

Flange, in contact with medium

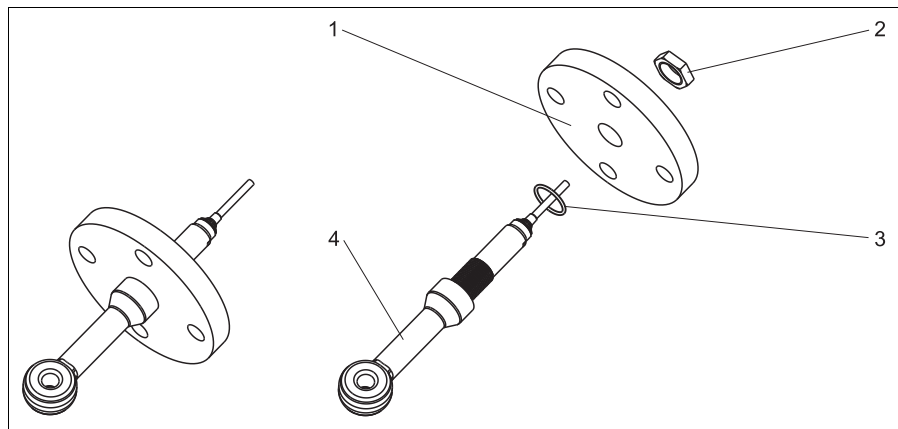

Fixed flange, in contact with medium (order option "process connection": 3, 4)

- | | | | |
|---|--------------------------|---|--------|
| 1 | Flange (stainless steel) | 3 | O-ring |
| 2 | Nut | 4 | Sensor |

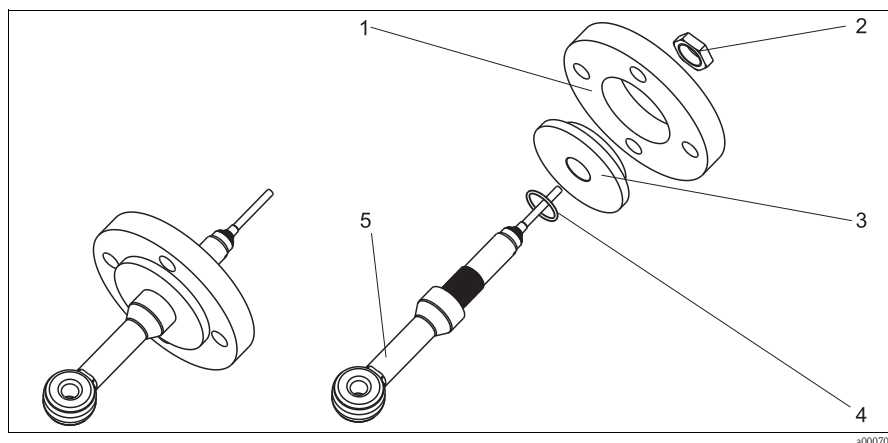
Lap-joint flange, not in contact with medium

Lap-joint flange, not in contact with medium (order option "process connection": A, B, C)

- | | | | |
|---|--------------------------|---|--------|
| 1 | Lap-joint flange (PP-GF) | 4 | O-ring |
| 2 | Nut (stainless steel) | 5 | Sensor |
| 3 | Flange (PVDF) | | |

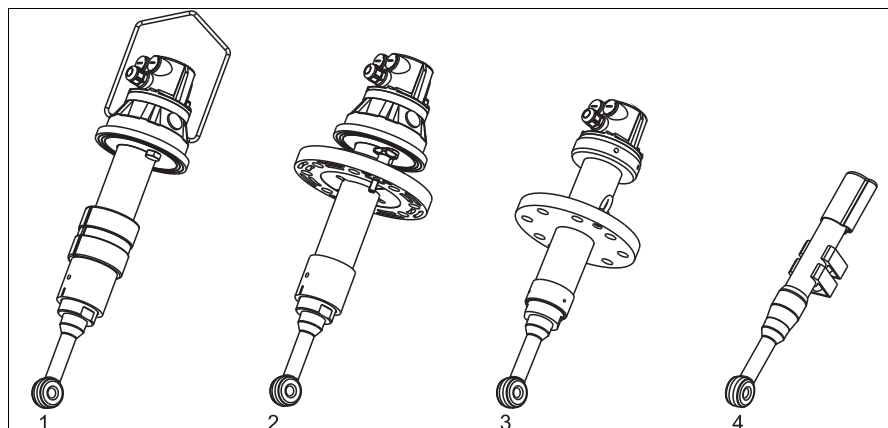
Installation of sensor assembly

Installation of sensor with assembly

- | | | | |
|---|--------------------------------|---|-------------------------------|
| 1 | CLA111 with suspension bracket | 3 | CLA140 with flange connection |
| 2 | CLA111 with flange connection | 4 | CYA611 |

Environment

Ambient temperature range -10 to +70 °C (+10 to +160 °F)

Storage temperature -20 to +80 °C (-4 to +180 °F)

Ingress protection IP 67 / NEMA 6 (installed with original sealing)

Process

Process temperature

CLS50D

-20 to 125 °C (-4 to 260 °F), acc. to the sensor version, see pressure-temperature diagram

CLS50

-20 to 180 °C (-4 to 360 °F), acc. to the sensor version, see pressure-temperature diagram

Process pressure

max. 20 bar (290 psi), acc. to the sensor version, see pressure-temperature diagram

Pressure-temperature diagram

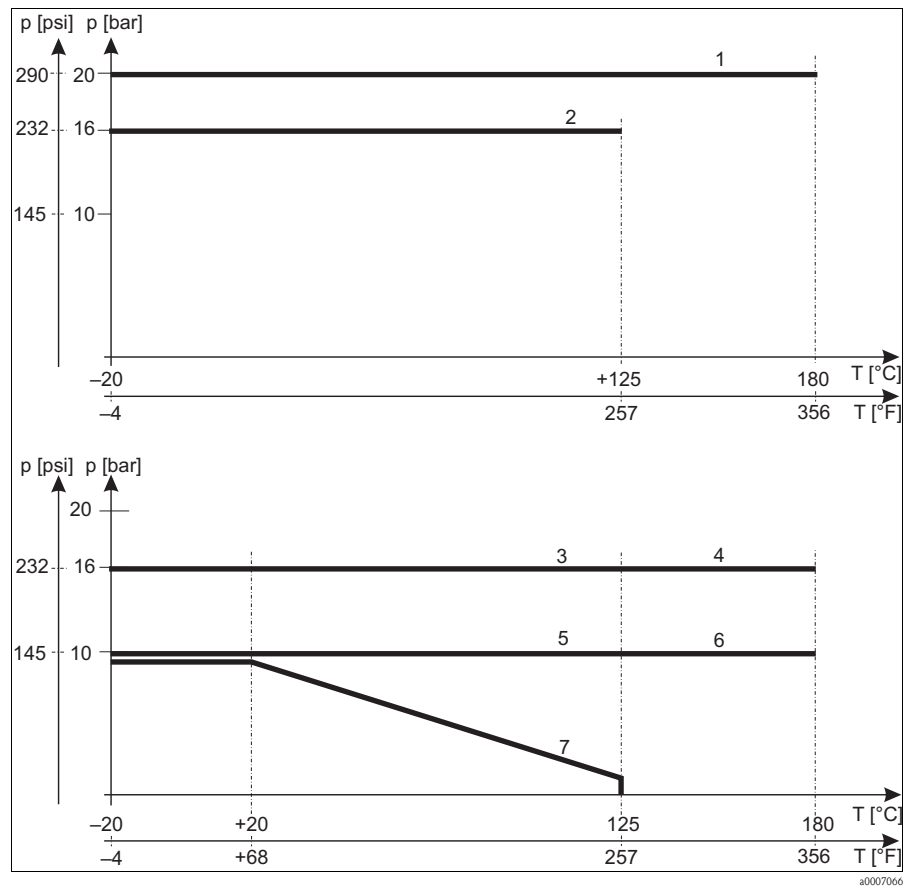

Pressure-temperature diagram (sensor versions, see Ordering information)

- 1 PEEK sensor, CLS50 up to 180 °C (356 °F), CLS50D up to 125 °C (257 °F), without flange
- 2 PFA sensor up to 125 °C (257 °F), without flange
- 3 PEEK/PFA sensor up to 125 °C (257 °F), with DN 50/ANSI 2" flange, 1.4404 (AISI 316 L)
- 4 PEEK sensor, CLS50 up to 180 °C (356 °F), CLS50D up to 125 °C (257 °F), with DN 50/ANSI 2" flange, 1.4404 (AISI 316 L)
- 5 PEEK/PFA sensor up to 125 °C (257 °F), with JIS flange, 1.4404 (AISI 316 L)
- 6 PEEK sensor, CLS50 up to 180 °C (356 °F), CLS50D up to 125 °C (257 °F), with JIS flange, 1.4404 (AISI 316 L)
- 7 PEEK/PFA sensor, with PVDF flange

Mechanical construction

Sensor dimensions

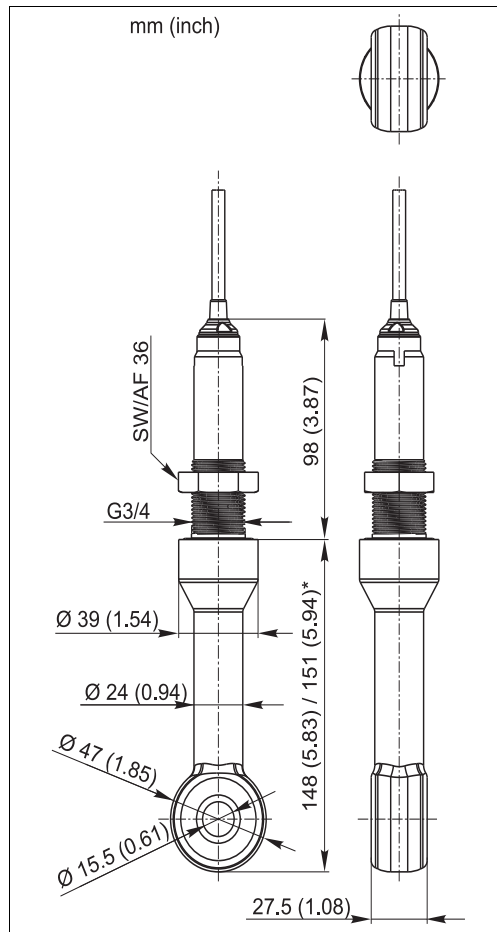

Dimensions of sensor version with G 3/4 thread

* Dimensions of PEEK version

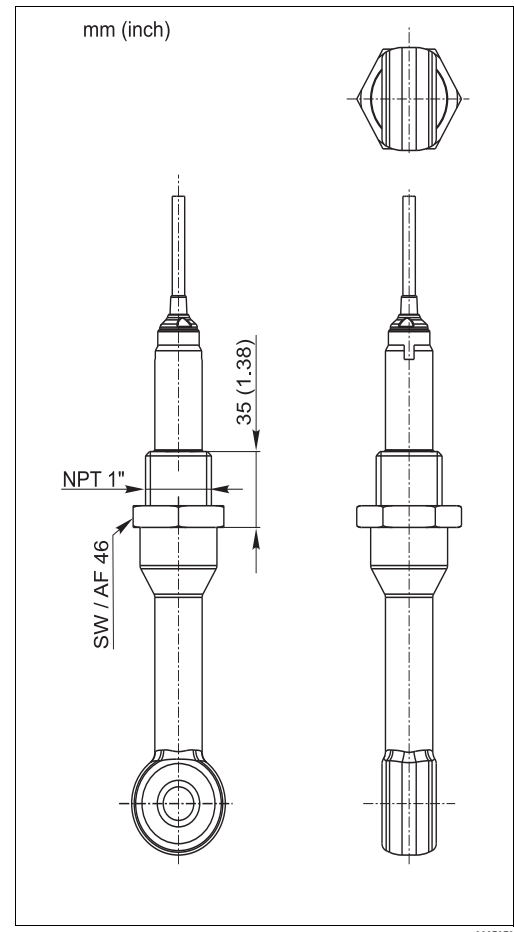

Dimensions of sensor version with NPT 1" thread

Flange dimensions

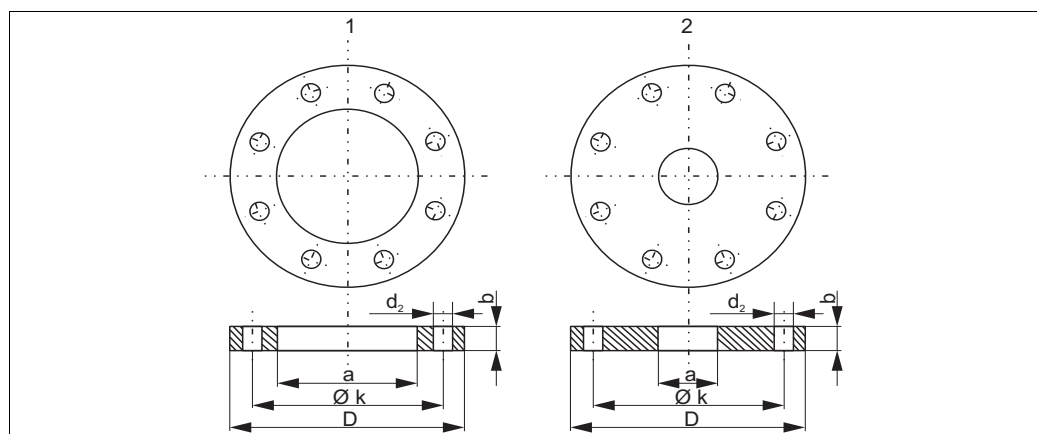

Flange dimensions

- 1 Lap-joint flange (PP-GF)
- 2 Fixed flange (stainless steel)

Lap-joint flange PP-GF	DN 50 PN 10	ANSI 2" 150 lbs	JIS 10K 50A
D	165	165	152
Ø k	125	121	120
d₂	4 x 18	8 x 19	4 x 19
b	18	18	18
a	78	78	78
Screws	M16	M16	M16

Fixed flange SS 316 L	DN 50 PN 16	ANSI 2" 300 lbs	JIS 10K 50A
D	165	165.1	155
Ø k	125	127	120
d₂	4 x 18	8 x 19	4 x 19
b	18	22.2	16
a	27	27	27
Screws	M16	M16	M16

Weight approx. 1350 g (2.98 lbs)

Material	Sensor:	PEEK, PFA (depending on ordered version)
	Sensor seal:	Viton [®] , Chemraz [®] (depending on ordered version)
	Process connections:	
	G ¾:	CLS50: stainless steel 1.4571 (AISI 316 Ti) CLS50D: PEEK
	NPT 1":	PEEK
	Fixed flange:	stainless steel 1.4404 (AISI 316 L)
	Sealing disk:	PTFE
	Lap-joint flange:	PP-GF
	Flange combined with lap-joint flange:	PVDF

Chemical durability

Medium	Concentration	PEEK	PFA	Chemraz [®]	Viton [®]
Sodium hydroxide solution NaOH	0 to 50 %	20 to 100 °C (68 to 212 °F)	20 to 80 °C (68 to 176 °F)	0 to 150 °C (32 to 302 °F)	not suitable
Nitric acid HNO ₃	0 to 5 %	20 to 60 °C (68 to 140 °F)	20 to 60 °C (68 to 140 °F)	0 to 150 °C (32 to 302 °F)	0 to 120 °C (32 to 248 °F)
	0 to 40 %	20 °C (68 °F)	20 to 60 °C (68 to 140 °F)	0 to 150 °C (32 to 302 °F)	0 to 120 °C (32 to 248 °F)
Phosphoric acid H ₃ PO ₄	0 to 50 %	20 to 60 °C (68 to 140 °F)	20 to 60 °C (68 to 140 °F)	0 to 150 °C (32 to 302 °F)	0 to 120 °C (32 to 248 °F)
Sulphuric acid H ₂ SO ₄	0 to 2.5 %	20 to 80 °C (68 to 176 °F)	20 to 100 °C (68 to 212 °F)	0 to 150 °C (32 to 302 °F)	0 to 120 °C (32 to 248 °F)
	0 to 30 %	20 (68 °F)	20 to 100 °C (68 to 212 °F)	0 to 150 °C (32 to 302 °F)	0 to 120 °C (32 to 248 °F)
Hydrochloric acid HCl	0 to 5 %	20 to 100 °C (68 to 212 °F)	20 to 50 °C (68 to 122 °F)	0 to 150 °C (32 to 302 °F)	0 to 120 °C (32 to 248 °F)
	0 to 10 %	20 to 100 °C (68 to 212 °F)	20 °C (68 °F)	0 to 150 °C (32 to 302 °F)	0 to 120 °C (32 to 248 °F)

No responsibility is taken for the correctness of this information.

Ordering information

Product structure

CLS50D

Approval	
AA	Non-hazardous area
BA	ATEX II 1G EEx ia IIC T4/T6
BV	ATEX II 3G Ex nL IIC T4/T6 + NEPSI Ex nL IIC T4/T6
C2	FM IS NI Cl . I, II, III, Div. 1&2, Group A-G
FB	CSA IS NI Cl . I, II, III, Div. 1&2, Group A-G
NA	NEPSI Ex ia IIC T4/T6

Process connection	
A	Lap joint flange DN 50 PN 10, PP-GF
B	Lap joint flange ANSI 2" 150 lbs, PP-GF
C	Lap joint flange JIS 10 K 50 A, PP-GF
1	Thread G ¾, stainless steel 1.4571 (AISI 316 Ti)
2	Thread NPT 1", PEEK
3	Flange DN 50 PN 16, stainless steel 1.4404 (AISI 316 L)
4	Flange ANSI 2" 300 lbs, stainless steel 1.4404 (AISI 316 L)
5	Flange DN 50 PN 16, stainless steel 1.4404 (AISI 316 L), PTFE sealing disk
6	Flange ANSI 2" 300 lbs, stainless steel 1.4404 (AISI 316 L), PTFE sealing disk
7	Flange JIS 10 K 50 A, stainless steel 1.4404 (AISI 316 L), PTFE sealing disk

Sensor material / seal	
A	PFA ; Chemraz®
B	PEEK ; Viton®
C	PEEK ; Chemraz®

Cable length	
1	3 m (9.84 ft)
2	7 m (23 ft)
3	15 m (49 ft)
7	... m fixed cable, max. 50 m
8	... ft fixed cable, max. 164 ft

Cable connection	
1	Fixed cable, terminated cable cores
2	Fixed cable, M12 plug

CLS50D-						order code
---------	--	--	--	--	--	-------------------

Calibration (single choice only)	
F1	Cell constant

Diensteistung (multiple choice possible)	
HC	LABS free (LABS = paint-wetting impairment substances)

TAG (multiple choice possible)	
1	TAG, see additional specification
2	Feldbus TAG

Note!

To complete your order code, simply add the options to the end of order code. If you have any questions, please contact your local sales office.

CLS50

Approval	
A	Non-hazardous area
G	ATEX II 1G EEx ia IIC T4/T6
H	NEPSI Ex ia IIC T4/T6
L	Non-hazardous area, PWIS free
O	FM IS NI Cl. I, II, III, Div. 1&2, Group A-G
S	CSA IS NI Cl. I, II, III, Div. 1&2, Group A-G
T	TIIS
V	ATEX II 3G Ex nL IIC T4/T6 + NEPSI Ex nL IIC T4/T6
Process connection	
A	Lap joint flange DN 50 PN 10, PP-GF
B	Lap joint flange ANSI 2" 150 lbs, PP-GF
C	Lap joint flange JIS 10 K 50 A, PP-GF
1	Thread G 3/4, stainless steel 1.4571 (AISI 316 Ti)
2	Thread NPT 1", PEEK
3	Flange DN 50 PN 16, stainless steel 1.4404 (AISI 316 L)
4	Flange ANSI 2" 300 lbs, stainless steel 1.4404 (AISI 316 L)
5	Flange DN 50 PN 16, stainless steel 1.4404 (AISI 316 L), PTFE sealing disk
6	Flange ANSI 2" 300 lbs, stainless steel 1.4404 (AISI 316 L), PTFE sealing disk
7	Flange JIS 10 K 50 A, stainless steel 1.4404 (AISI 316 L), PTFE sealing disk
Sensor material ; seal	
A	PFA ; Chemraz®
B	PEEK ; Viton®
C	PEEK ; Chemraz®
Cable length and temperature range	
1	5 m (16 ft) fixed cable, max. 125 °C (257 °F)
2	10 m (32 ft) fixed cable, max. 125 °C (257 °F)
3	20 m (65 ft) fixed cable, max. 125 °C (257 °F)
4	fixed cable of specific length, max. 55 m (180 ft), max. 125 °C (257 °F)
5	5 m (16 ft) fixed cable, max. 180 °C (356 °F) (PEEK only, version for non-hazardous areas only)
6	10 m (32 ft) fixed cable, max. 180 °C (356 °F) (PEEK only, version for non-hazardous areas only)
CLS50-	complete order code

Certificates and approvals

Ex approvals

CLS50

- ATEX II 1G Ex ia IIC T3/T4/T6
- ATEX II 3G Ex nL IIC T4/T6 + NEPSI Ex nL IIC T4/T6
- FM/CSA IS NI Cl. I, II, III, Div. 1 & 2; Group A - G in connection with a Liquiline CM42 or Mycom CLM153 transmitter
- NEPSI Ex ia IIC T4/T6

Accessories

Measuring cables

For CLS50D

CYK81 measuring cable

- Non-terminated measuring cable for extension of sensor cables of e.g. Memosens sensors, CUS31/CUS41
- 2 wires, twisted pair with shield and PVC-sheath (2 x 2 x 0.5 mm² + shield)
- Sold by the meter, order no.: 51502543

Junction box RM

- For cable extension (e.g. for Memosens sensors)
- 5 terminals
- Cable entries: 2 x Pg 13.5
- Material: PC
- Ingress protection: IP 65
- Order no.: 51500832

For CLS50

Extension cable CLK5

- For inductive conductivity sensors, for extension via the VBM junction box, sold by the meter
- Order no.: 50085473

Junction box VBM

- For cable extension
- 10 terminals
- Cable entries: 2 x Pg 13.5 or 2 x NPT ½"
- Material: aluminum
- Ingress protection: IP 65 (≅ NEMA 4X)
- Order numbers:
 - cable entries Pg 13.5: 50003987
 - cable entries NPT ½": 51500177

Transmitters

For CLS50D

Liquiline CM44x

- Multiple-channel transmitter for the connection of digital sensors with Memosens technology
- Power supply: 85 to 265 V AC, 18 to 36 V DC or 20 to 28 V AC (not CM448)
- Universally upgradeable
- SD card slot
- Alarm relay
- IP 66
- Ordering acc. to product structure (Technical Information TI444C/07/en)

For CLS50

Liquiline CM42 (for analog conductivity sensors and digital conductivity sensors with Memosens technology)

- Modular two-wire transmitter for Ex and non-Ex areas
- Hart®, PROFIBUS or FOUNDATION Fieldbus available
- Ordering acc. to product structure, see Technical Information (TI381C/07/en)

Liquisys CLM223/253 (for analog conductivity sensors)

- Transmitter for conductivity, field or panel-mounted housing,
- Hart® or PROFIBUS available
- Ordering acc. to product structure, see Technical Information (TI193C/07/en)

Mycom CLM153 (for analog conductivity sensors)

- Transmitter for conductivity, one or two channel version, Ex or Non-Ex,
- Hart® or PROFIBUS available
- Ordering acc. to product structure, see Technical Information (TI234C/07/en)

Assemblies

Dipfit CLA111

- Immersion assembly for open and closed tanks with flange DN 100;
- Ordering acc. to product structure, see Technical Information TI135C/07/en

Dipfit CLA140

- For the inductive sensor CLS50/CLS50D
- Immersion assembly with flange connection for highly demanding processes;
- Ordering acc. to product structure, see Technical Information TI196C/07/en

Immersion assembly Dipfit CYA611

- For sensor immersion in basins, open channels and tanks, PVC
- Ordering acc. to product structure, see Technical Information TI166C/07/en

Calibration solutions

Precision solutions, traceable to SRM (standard reference material) by NIST, for qualified calibration of conductivity measurement systems according to ISO 9000, with temperature table

- CLY11-B
149.6 $\mu\text{S}/\text{cm}$ (reference temperature 25 °C / 77 °F), 500 ml / 16.9 fl.oz
Order no. 50081903
- CLY11-C
1.406 mS/cm (reference temperature 25 °C / 77 °F), 500 ml / 16.9 fl.oz
Order no. 50081904
- CLY11-D
12.64 mS/cm (reference temperature 25 °C / 77 °F), 500 ml / 16.9 fl.oz
Order no. 50081905
- CLY11-E
107.0 mS/cm (reference temperature 25 °C / 77 °F), 500 ml / 16.9 fl.oz
Order no. 50081906

Instruments International

Endress+Hauser
Instruments International AG
Kaegenstrasse 2
4153 Reinach
Switzerland

Tel.+41 61 715 81 00
Fax+41 61 715 25 00
www.endress.com
info@ii.endress.com

Endress+Hauser 
People for Process Automation