

MODEL 500 ANALYZER

MODEL 500 ANALYZER
Is used for the following tests:

Microtox Acute Toxicity
Microtox Chronic Toxicity
Mutatox
ATP



ANALYZER SET UP AND SAFETY PRECAUTIONS

1. Remove the Model 500 from the shipping carton. Examine the equipment for signs of shipping damage. Save the carton.

The optimum location is dust free, with no exposure to direct sunlight. Six inches (15 cm) of clearance should be allowed between the back and sides of the analyzer and walls, or other equipment. The analyzer should sit on a smooth, hard surface. Do not place the analyzer on paper or cloth, which may impede air flow, and prevent the analyzer from cooling properly.



Warning ISO 3864, No. B.3.1

Caution (refer to accompanying documents)

2. Do not connect the analyzer to electrical power until verifying that the voltage setting and fuse are correct for the electrical power available.



Warning ISO 3864, No. B.3.6

Caution, risk of electric shock

**Warning High Voltage Located Inside
Disconnect Power for 10 Minutes
Before Opening.**

If you are unfamiliar with the power line connector box containing the fuse and voltage selection board, see the detailed discussion below.

Connect the power cable (No.1) to the power receptacle (No.1) on the rear panel of the Model 500. (Each cable in the system is numbered, and each connector on the equipment is numbered to match. Plug similar numbers together. Only one end of a cable will fit a particular connector.)

Plug the other end of cable into a 3-prong grounded power outlet.

The 3-prong power cord must be connected only to a 3-hole grounded outlet. Do not use an adapter to connect the power plug to a 2-hole power outlet.

Do not operate the analyzer until an electrical ground is provided and the power cord is properly connected to ground.



Warning - The Model 500 has no on/off switch; as it is hard on the analyzer to turn it on and off all the time. The analyzer should remain on unless it will not be used for a prolong period of time.

As soon as the analyzer is plugged in, it will begin operation. The red temperature warning indicator light will appear on the front panel, and it will remain on until the incubator wells reach their operating temperature. The green READY Light will then appear.

ANALYZER FEATURES

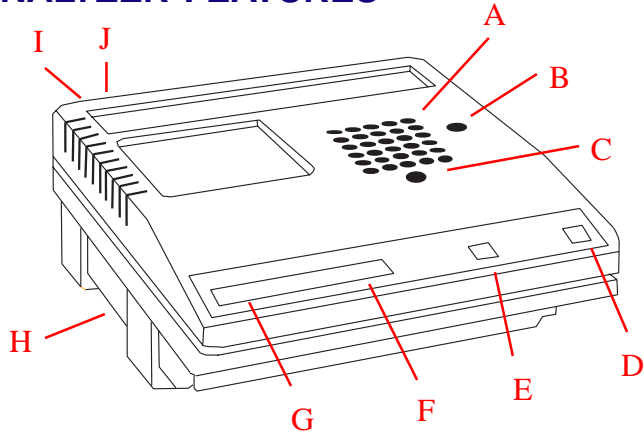

- A.** Thirty-well incubator block with temperature control. This is where tests are performed.
- B.** REAGENT Well with temperature control. This is where the reconstituted reagent is stored.
- C.** READ Well with temperature control. This is where the reagent light levels are measured.

- D.** SET Button. When this button is pressed, the system automatically calibrates the analyzer to the light output of the reagent currently in the READ Well.
- E.** READ Button. When a cuvette containing reagent is placed in the READ Well, and this button is pressed, the analyzer measures the light output of the reagent.
- F.** Warning and Indicator Lights. The functions of these lights are described in the Troubleshooting section of this manual.
- G.** Digital display, where the light levels are indicated.
- H.** Cooling fan and filter, located on the bottom center of the analyzer.
- I.** Power and communication connections, fuse, voltage selector (on back).
- J.** Mode selector switch, to set temperature (on back).

SPECIFICATIONS

Power Requirements for Model 500

100 +/- 10% VAC, 2 Amp Slo Blo, 50/60 Hz

120 +/- 10% VAC, 2 Amp Slo Blo, 50/60 Hz

220 +/- 10% VAC, 1 Amp Slo Blo, 50/60 Hz

240 +/- 10% VAC, 1 Amp Slo Blo, 50/60 Hz

Analyzer Size

Height 7 1/8 inches (18.3 cm)

Width 15 3/8 inches (39.1 cm)

Depth 16 1/8 inches (41.2 cm)

Weight 21 pounds (9.5 Kg)

Room Temperature Requirement

15°C to 30°C

Temperature

REAGENT well 5.5°C ± 1°C

Acute Mode

Incubator block 15°C ± 0.5°C

READ well 15°C ± 1.0°C

Mutatox Mode

Chronic / ATP Mode

Incubator block 27°C ± 0.5°C

READ well 27°C ± 1.0°C

PREPARING THE MODEL 500

When the Model 500 is first plugged into a power source, the unit brings the REAGENT Well, the incubator wells, and the READ Well to preset temperatures, then maintains those temperatures automatically.

When the unit is first plugged in, the red “Temperature Warning Indicator Light” on the front panel of the unit switches on. The REAGENT well is maintained at a different temperature from that of the READ, and incubator wells. If any of those wells drifts from its assigned temperature, the Temperature Warning Indicator Light switches on.

The incubator wells should reach their set temperatures within fifteen to thirty minutes, depending on ambient conditions, and the Temperature Warning Indicator Light will switch off.

If it doesn't switch off, check the troubleshooting instructions.

When the green READY Light switches on, the Model 500 is ready to run tests.

No additional adjustments or calibrations are necessary.

LINE VOLTAGE SELECTION

Model 500 Analyzers can operate on 100 to 240 AC power.

The configured options are:

100 volts, 50/60 Hz, 2 ampere

120 volts, 50/60 Hz, 2 ampere

220 volts, 50/60 Hz, 1 ampere

240 volts, 50/60 Hz, 1 ampere

If the analyzer is moved to a different location, with a different voltage source, or if the power supply changes, the voltage setting of the analyzer can easily be changed to match the power supply by reorienting the “line voltage selector board,” and, if necessary, changing the fuse.

"Note" it may be necessary to change power cord to adapt unit to plug configuration of wall supply

LINE VOLTAGE SELECTOR BOARD

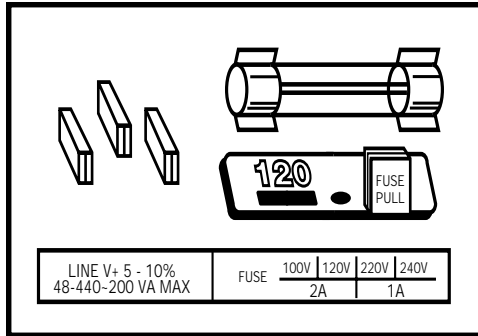

The line voltage selector board and fuse are located next to the power cord receptacle on the back of the analyzer.

The very small voltage selector board can be seen beneath the fuse. You can read the current voltage selection on the card when it is in place.



HOW TO CHANGE LINE VOLTAGE

- a) Disconnect the analyzer from the power source.
- b) Remove the power cord from its receptacle and slide the plastic cover to the left.
- c) Swing the FUSE PULL lever out and to the left.
- d) Remove the fuse for better accessibility to the line voltage selector board.
- e) Remove the board. This can be done by threading a piece of wire through the small hole at the edge of the board, and pulling the board horizontally. Be careful not to bend or scratch the board. There will be some resistance, due to the friction of the electrical contacts holding the board in place.

- f) Examine both sides of the board.

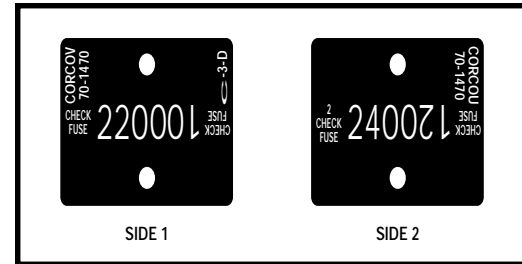

The board can be inserted in its slot so that any one of the four different voltage settings can be read from outside the unit.

- g) Insert the board with the desired voltage setting visible.
- h) Insert an appropriate fuse, selected from this table:
 - 100 +/- 10% VAC, 2 Amp Slo Blo, 50/60 Hz
 - 120 +/- 10% VAC, 2 Amp Slo Blo, 50/60 Hz
 - 220 +/- 10% VAC, 1 Amp Slo Blo, 50/60 Hz
 - 240 +/- 10% VAC, 1 Amp Slo Blo, 50/60 Hz

This completes the voltage conversion. The analyzer is again ready to be plugged in, and used.

Analyzer Testing Mode

The back of the Model 500 Analyzer has a 3-way toggle switch for the selection of testing mode.

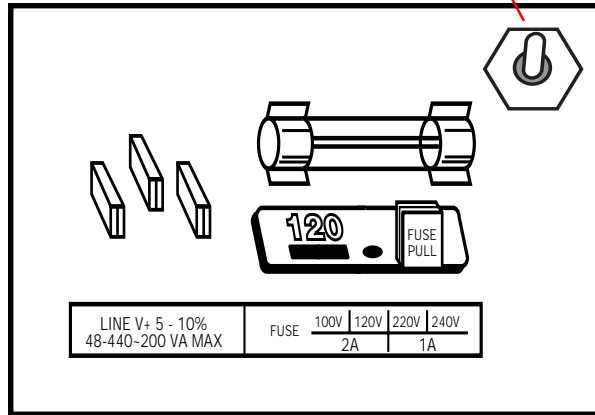

This will set the testing temperature and light level reading mode required for the type of test chosen.

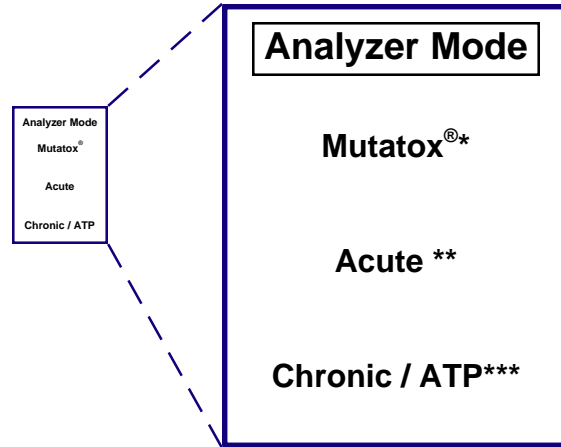

* Mutatox® Genotoxicity Test

** Microtox® Acute Toxicity Test

*** Microtox® Chronic Toxicity Test & ATP Test

MAINTENANCE OF THE MODEL 500 ANALYZER

Maintenance of the Model 500 analyzer is very simple:

- **Warning - Disconnect Power** 
- Keep the surface of the Model 500 clean, periodically clean the surface of the analyzer using distilled water.
- Keep the air filter clean, periodically clean the air filter using distilled water.

TROUBLESHOOTING THE MODEL 500 INSTRUMENT

Model 500 Indicator Lights



1) Motor Warning Light

The READ Well motor is in overload. If this lights up, press the READ button to recycle the mechanism. If this does not clear the problem, and the shutter is closed, try rocking the shutter gently to free it. Once the shutter is open, inspect for glass or other debris in the well. If the problem persists, call Azur Environmental for advice.

2) Zero Warning Light

If this warning light appears after the SET button has been pressed, the analyzer is unable to establish a zero setting during automatic calibration. The problem may be caused by strong direct light falling on the analyzer. Always shade the analyzer from direct sunlight and from any unusually strong artificial light. If the problem persists, call Azur Environmental for advice.

3) Signal Low Warning Light

If this warning light appears after the SET button has been pressed, the reagent light level is too low, so that the analyzer cannot set the upper level at 95, plus or minus 5, during automatic calibration. The problem may be caused by one of these factors:

1. Reagent was never added to the cuvette.
2. When the reagent was reconstituted, the liquid was added to the dry reagent too slowly, damaging the cells.
3. Ultra pure water was used in place of diluent.
4. The reconstituted reagent is too old, and should be replaced with freshly reconstituted reagent.
5. The pipettor may be contaminated.
6. The diluent may be contaminated or homemade.
7. The cuvette may be contaminated or reused.

4) Signal High Warning Light

If this warning light appears after the SET button is pressed, the reagent light level is too high, so that the analyzer cannot set the upper level at 95, plus or minus 5, during automatic calibration. The problem may be caused by one of these factors:

1. The cuvette from the REAGENT Well, containing the reserve suspension of reagent, has been placed in the READ Well, instead of the Control cuvette.
2. Too much reagent suspension has been transferred into the Control cuvette.

5) Temperature Warning Light

This indicates that the temperature is too high or too low in one or more locations.

Proper REAGENT Well temperature is 5.5°C plus or minus (\pm) 1°C.

Proper Incubator Block and READ Well temperature is 15°C \pm 0.5°C in Microtox mode or 27°C \pm 0.5°C in Mutatox mode.

If this warning light appears, check the ambient room temperature. If it is too hot (above 30°C/86°F) or too cold (below 15°C/59°F), stop performing tests until the room temperature is appropriate or move the analyzer into a temperature controlled room.

The air flow through the analyzer may be impeded, allowing the temperature to rise too high.

Clean the air filter on the bottom of the Model 500 analyzer as a dirty filter will impede air flow.

If the back or sides of the analyzer are closer than six inches to walls or other objects...or if the surface on which it sits is not smooth. Cloth, carpet, or other textured

surfaces may prevent the analyzer from cooling properly.

Other instruments that produce heat may be too close to the Model 500 Analyzer, raising the local temperature too high.

If the air filter is clean, ambient temperature is within the proper range, the analyzer is properly placed, and the temperature warning light still stays on, call Azur Environmental for advice.

6) Mutatox Light

When this indicator light is on, the analyzer is in the Mutatox mode.

7) Chr Light

When this indicator light is on, the analyzer is in the Chronic/ATP mode.

8) Ready Light

The green READY light signals that the instrument is ready to read a sample. When the SET button is pressed, the READY light goes off until the analyzer has completed automatic calibration, then it comes back on.

OTHER PROBLEMS



Liquid In The READ WELL

If liquid is accidentally spilled into the READ Well, or if a cuvette in the READ Well is leaking:

- **Warning - Disconnect the power source.**
- **Wait 10 minutes.**
- Pipette as much liquid as possible from the cuvette before removing the cuvette from the well.
- Use cotton swabs to remove the remaining liquid from the well.

Liquid In The Wells

Liquid may condense from the air into the cool REAGENT Well. Remove the liquid from the well(s), using cotton swabs. Keep an empty cuvette in the REAGENT Well to minimize the rate of condensation when reagent is not stored in the well. The incubator wells are not as cold as the REAGENT Well, and are less likely to accumulate liquid, but they can also be dried with cotton swabs under extremely humid conditions. Empty cuvettes stored in unused incubator wells will also reduce condensation there.

Large Variability In I_0 Light Levels

Caused by improper use of the pipettor or by pipettor malfunction or inadequate mixing of the reagent during preparation. Review the pipettor instructions.

Light Loss Is Complete For All Sample Dilutions At 5 Minutes, The Control Light Level Is Normal

The sample was inhibitory at all the concentrations tested. Rerun the sample, using the Basic Test protocol (with 13 dilutions) , or make a primary dilution, and rerun the test using the same test protocol.

A Precipitate Forms When OAS Or Solid NaCl Is Added To The Sample

The NaCl is precipitating the sample. Replace the diluent (2% NaCl) with a 20% solution of sucrose. Osmotically adjust the sample by adding 20% solid sucrose to it. For example, 500 mg of solid sucrose is added to 2500 μ l of sample. The 20% sucrose provides the same osmotic protection as the 2% NaCl.