

# astroTOC™ UV Process Total Organic Carbon Analyzer

## Features and Benefits

### Modular Industrial Design

The Hach astroTOC UV Process Total Organic Carbon (TOC) Analyzer is a rugged, low-maintenance analyzer designed to withstand the most severe conditions. A true process analyzer, it also features a dual-compartment enclosure that separates and protects the electronics from the analytical section. Modular, streamlined construction and large-bore flow paths simplify maintenance and service. For severe applications, an optional self-cleaning blowback filter removes large particles from sample lines. An optional air purifier improves the quality of the compressed air supply by removing CO<sub>2</sub>. The modular design also permits a wide spectrum of factory-set analysis ranges.

### Advanced Diagnostics/Spill Conditions

The advanced diagnostics of the astroTOC UV analyzer help protect the analyzer during process spill conditions. Loss of sample and loss of UV reactor flow are standard integrated diagnostic features, as well as loss of sparger flow, loss of carrier gas, and pump tube deterioration. Optional alarms for reagent levels and enclosure spills are also available. During a spill event, operators can attend to other instruments while the astroTOC UV remains protected. A programmable process spill threshold automatically takes the instrument off-line and into auto-clean mode when TOC readings exceed this threshold. The instrument auto recovers and returns to standard operation when TOC measurements return to acceptable levels.

### Flexible Analysis System

The astroTOC UV analyzer features a dual-range, non-dispersive infrared (NDIR) CO<sub>2</sub> detection of TOC with a multi-staged UV lamp reactor and on-board sample dilution. While the analyzer is factory-set for a single range, it can be easily adapted to a broad and flexible selection of ranges, from 0 to 20,000 mg/L TOC.

### Simplified Maintenance

The astroTOC UV analyzer is designed to simplify analyzer maintenance and keep equipment running smoothly with the automated validation, calibration, and cleaning features. The astroTOC UV analyzer can be programmed to go offline automatically and enter into validation, calibration, or cleaning sequences. This allows the instrument to maintain accuracy without time-consuming operator interaction. The limits are set once and the instrument performs automatically.

The astroTOC UV analyzer also features an automated Grab Sample mode that, when engaged, will instruct the analyzer to automatically go offline, analyze the sample, then purge with stream sample and go back online. The result is that that operator does not have to wait for the analysis to be complete and return the analyzer to online mode.



*The Hach astroTOC UV Process Total Organic Carbon Analyzer is designed to withstand the most severe industrial conditions. Advanced diagnostics and a flexible analysis system allows analysis of hard-to-oxidize samples. A drift- and interference-free NDIR detector with a PVDF (KYNAR) flow-through cell is impervious to corrosion.*

### Based on an Established Platform

The astroTOC UV analyzer is designed and manufactured based on more than 25 years of industry-leading TOC analysis experience. With thousands of installations worldwide, this analyzer was developed with input from many end users and an extensive global service network.

### Detection Method

ASTM, EN, EPA, ISO and Standard Methods recommend TOC analysis methods using NDIR detection. This technique provides stable, accurate measurement by detecting CO<sub>2</sub> gas. The astroTOC UV analyzer performs CO<sub>2</sub> measurement and compares it against a reference measurement. The difference between the two measurements is equal to the concentration of CO<sub>2</sub> present. The NDIR detection in the astroTOC UV analyzer measurement cell follows a direct path to a concave mirror and a bundled path back to the receiver. This avoids the inherent drawbacks of the wall-bounce path, including loss of sensitivity and inaccurate measurement due to the interference of dust particles or water droplets on the NDIR cell wall.

### Non-corrosive NDIR Detector

The cell body of the Hach astroTOC UV Process TOC Analyzer NDIR detection system is made of PVDF (KYNAR) that is impervious to corrosion. The mirror and window are made of sapphire, which is less susceptible to scratching and therefore helps to provide a continuously accurate measurement.

DW = drinking water WW = wastewater municipal PW = pure water / power  
IW = industrial water E = environmental C = collections FB = food and beverage



Be Right™

## Specifications\*

### Range

0 to 5 up to 20,000 mg/L TOC

### Analysis Method

UV persulfate oxidation with acid sparging for TIC removal followed by CO<sub>2</sub> NDIR detector measurement

### Accuracy

± 2% of full scale, non-diluted ranges at 25°C (77°F)  
± 4% of full scale, diluted ranges at 25°C (77°F)

### Repeatability

± 2% of reading, non-diluted ranges at 25°C (77°F)  
± 4% of reading, diluted ranges at 25°C (77°F)

### Minimum Detection Limit

≤0.015 mg/L for range 0 to 5 mg/L at 25°C (77°F)

### Response Time

T90 ≤8 minutes (includes TIC sparging and may vary according to range)

### Inlet Pressure

0.15 to 6 bar (2 to 87 psig)

### Flow Rate

25 to 200 mL/min

### Sample Temperature

2 to 70°C (36 to 158°F)

### Operating Temperature

5 to 40°C (41 to 104°F)

### Recorder Outputs

Two 4-20 mA analog outputs selectable for sample concentration, analyzer system warning, or auto-range indication

### Alarms

Five relays selectable for sample concentration alarm, analyzer system warning, or analyzer system shutdown alarm. Each is equipped with SPDT relay with contacts rated for 3 A resistive load at 250 Vac or 0.5 A at 30 V.

### Optional Serial Communication

One multi-function RS232 or RS485 serial port (ModBUS, CSV)

### Power

115/230 Vac 50/60 Hz (switch selectable), 300 VA maximum

### Sample Inlet/Outlet Connection

1/4-in. OD tube, compression fitting

### Drain Connection

1 1/2-in. OD standard drain pipe

### Carrier Gas

1/8-in. OD tube, compression fitting  
Clean, CO<sub>2</sub>-free air or Nitrogen at 2.8 to 6.2 bar (40-90 psig)

### Compliance/Certification

CE certified, listed to UL and CSA safety standards by ETL, Standard Methods 5310 C, EPA 415.1

### Enclosure

Cold rolled steel epoxy powder coated, optional stainless steel

### Mounting

Wall-mount

### Dimensions

981 x 675 x 220 mm (38.6 x 26.6 x 8.7 in.)

### Weight

54 kg (120 lbs.)

\*Specifications subject to change without notice.

## Principle of Operation

The Hach astroTOC UV Process TOC Analyzer combines chemical and ultraviolet oxidation techniques in a low-temperature reactor to deliver direct TOC measurements. It uses a multi-staged UV oxidation reactor and a chemically impervious, non-dispersive infrared (NDIR) CO<sub>2</sub> detector system to assure full compliance with Standard Methods 5310 C and EPA method 415.1.

In the first analysis step, the sample is mixed with acid, converting the total inorganic carbon (TIC) into CO<sub>2</sub>. The TIC sparger removes all the CO<sub>2</sub> from the sample solution. Then, the TIC-free sample is mixed with sodium persulfate and routed through the UV reactor, oxidizing the TOC into CO<sub>2</sub>. The gas/liquid mixture is transported by the carrier gas into the gas-liquid separator (GLS), where the sample gas is separated and diverted into the NDIR detector for direct, interference-free CO<sub>2</sub> measurement. The resulting measurement is directly proportional to the original TOC concentration of the sample.

## Engineering Specifications

- The TOC analyzer shall employ UV/Persulfate oxidation utilizing a multi-staged UV-Reactor coupled with a NDIR CO<sub>2</sub> detection system to measure TOC.
- The analyzer shall be constructed with dual enclosures with analytical/electrical separation.
- The enclosure of the analyzer shall be epoxy powder-coated cold rolled steel.
- The analyzer shall be compliant with Standard Methods 5310 C and EPA Method 415.1.
- The analyzer shall be equipped with grab sample and validation utilities for unknown sample or reference standard measurement.
- The analyzer shall be equipped with user programmable auto calibration, auto validation, and auto cleaning.
- The analyzer shall be equipped with loss of sample flow and reactor feed detection capabilities.
- The analyzer shall be equipped with a hinged pump assembly module.
- The analyzer shall be equipped with two 4-20 mA parameter mapped analog outputs.
- The analyzer shall be equipped with user programmable auto ranging capabilities over four ranges.
- The analyzer shall be equipped with 5-volt, free-function mapped relay outputs.
- The analyzer shall be available with an optional RS232 or RS485 serial communication output (ModBUS, CSV).
- The analyzer shall be CE certified, listed to UL and CSA Safety Standards by ETL.
- The analyzer shall be the astroTOC UV Process Total Organic Carbon (TOC) Analyzer manufactured by Hach Company.

## Dimensions

The Hach astroTOC UV Process Total Organic Carbon (TOC) Analyzer is designed to be wall-mounted with four 10-mm (3/8-in.) screws. Adequate clearance must be left at the sides and bottom of the enclosure for plumbing and electrical connections. The sample inlet connection is 6-mm (1/4-in.) OD tube compression fitting and the drain connection is 3.8-cm (1 1/2-in.) OD standard drain pipe. Electrical connections are inside the instrument. Four thru-holes for 1/2-in. conduit fittings or four PG13.5 strain reliefs are provided.

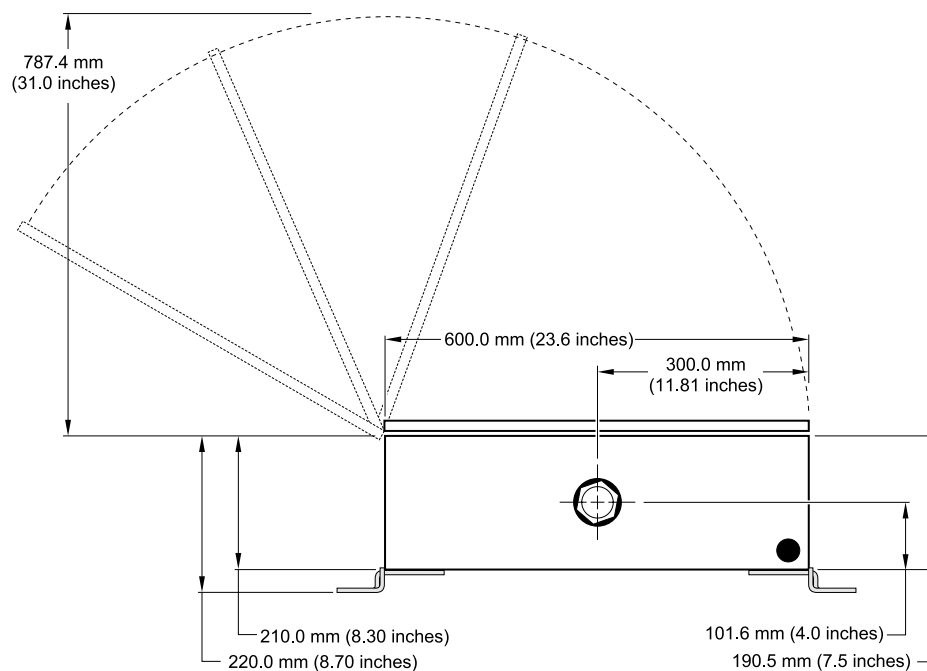
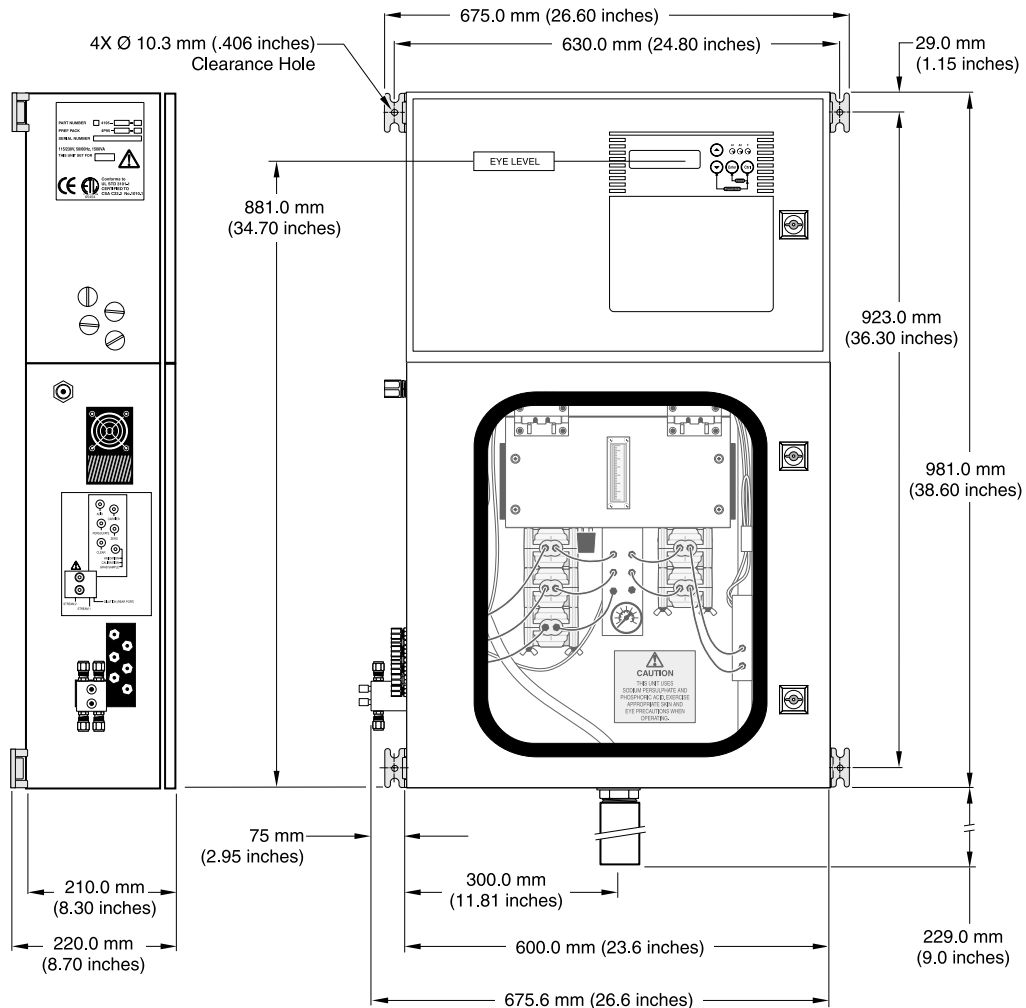

## Ordering Information

Hach astroTOC UV Process TOC Analyzers are shipped with a start-up kit and an operator's manual. An analyzer and a preference package part number must be selected from below.

### Analyzers

Cold Rolled Steel Enclosure	Stainless Steel Enclosure	astroTOC UV Process Analyzer with 1 UV Lamp
H-4195-1010	H-4195-3010	0 to 5 mg/L
H-4195-1020	H-4195-3020	0 to 10 mg/L
H-4195-1030	H-4195-3030	0 to 25 mg/L
H-4195-1040	H-4195-3040	0 to 50 mg/L
H-4195-1050	H-4195-3050	0 to 100 mg/L
Cold Rolled Steel Enclosure	Stainless Steel Enclosure	astroTOC UV Process Analyzer with 1 UV Lamp and Dilution
H-4195-1060	H-4195-3060	0 to 200 mg/L
H-4195-1070	H-4195-3070	0 to 500 mg/L
Cold Rolled Steel Enclosure	Stainless Steel Enclosure	astroTOC UV Process Analyzer with 2 UV Lamps
H-4195-2000	H-4195-4000	0 to 100 mg/L
H-4195-2010	H-4195-4010	0 to 200 mg/L
H-4195-2020	H-4195-4020	0 to 500 mg/L
H-4195-2030	H-4195-4030	0 to 1000 mg/L
Cold Rolled Steel Enclosure	Stainless Steel Enclosure	astroTOC UV Process Analyzer with 2 UV Lamps and Dilution
H-4195-2040	H-4195-4040	0 to 1000 mg/L
H-4195-2050	H-4195-4050	0 to 2000 mg/L
H-4195-2060	H-4195-4060	0 to 5000 mg/L
H-4195-2070	H-4195-4070	0 to 10,000 mg/L
H-4195-2080	H-4195-4080	0 to 20,000 mg/L

### Preference Packages (Cold Rolled Steel Enclosure)

115V	230V	Description
4P95-1000-00	4P95-2000-00	Basic Unit (no charge)
4P95-1001-00	4P95-2001-00	Level Detection Kit
4P95-1010-00	4P95-2010-00	Additional UV Lamp
4P95-1011-00	4P95-2011-00	Additional UV Lamp/Level Detection Kit
4P95-1100-00	4P95-2100-00	View Window
4P95-1101-00	4P95-2101-00	View Window & Level Detection Kit
4P95-1110-00	4P95-2110-00	View Window & Additional UV Lamp
4P95-1111-00	4P95-2111-00	View Window, Additional UV Lamp, & Level Detection Kit

### Preference Packages (Stainless Steel Enclosure)

115V	230V	Description
4P95-1300-00	4P95-2300-00	View Window (no charge)
4P95-1301-00	4P95-2301-00	View Window and Level Detection Kit
4P95-1310-00	4P95-2310-00	View Window and Additional UV Lamp
4P95-1311-00	4P95-2311-00	View Window, Additional UV Lamp, & Level Detection Kit

### Accessories

120161	Free-standing Rack Assembly	4200-1005	PS200 Blowback Filter with 500 µm filter (FM rated)
200123	1 Yr. Spare Parts Kit	4300-0003	AAS 300 CO <sub>2</sub> Air Purifier with Pneumatic Timer; for use with compressed air (for hazardous locations)
200124	2 Yr. Spare Parts Kit	6948600	Kalrez O-ring Kit
4000-0011	Z-Purge Kit (for installing in hazardous locations), LF/RT Mount, CL1 DIV2, A-D (Requires Prod. No. 200130 Pneumatic Condenser Cooler Kit)	4300-0005	Purge Gas Generator, 120/240 Vac
4200-1004	PS200 Blowback Filter with 25 µm filter (FM rated)	4300-0008	Purge Gas Generator with compressor, 120V
4200-1002	PS200 Blowback Filter with 50 µm filter (FM rated)	200130	Pneumatic Condenser Cooler (for installing in hazardous locations)
4200-1001	PS200 Blowback Filter with 100 µm filter (FM rated)	200137	Dual Stream Retrofit Kit (adding dual stream option to existing analyzer)
4200-1003	PS200 Blowback Filter with 300 µm filter (FM rated)		

LIT2432 Rev 2

E12 Printed in U.S.A.

©Hach Company, 2012. All rights reserved.

In the interest of improving and updating its equipment, Hach Company reserves the right to alter specifications to equipment at any time.



*At Hach, it's about learning from our customers and providing the right answers. It's more than ensuring the quality of water—it's about ensuring the quality of life. When it comes to the things that touch our lives...*

*Keep it pure.*

*Make it simple.*

*Be right.*

*For current price information, technical support, and ordering assistance, contact the Hach office or distributor serving your area.*

*In the United States, contact:*

HACH COMPANY World Headquarters  
P.O. Box 389  
Loveland, Colorado 80539-0389  
U.S.A.  
Telephone: 800-227-4224  
Fax: 970-669-2932  
E-mail: orders@hach.com  
**www.hach.com**

*U.S. exporters and customers in Canada, Latin America, sub-Saharan Africa, Asia, and Australia/New Zealand, contact:*

HACH COMPANY World Headquarters  
P.O. Box 389  
Loveland, Colorado 80539-0389  
U.S.A.  
Telephone: 970-669-3050  
Fax: 970-461-3939  
E-mail: intl@hach.com  
**www.hach.com**

*In Europe, the Middle East, and Mediterranean Africa, contact:*

HACH LANGE GmbH  
Willstätterstraße 11  
D-40549 Düsseldorf  
GERMANY  
Tel: +49 (0) 211 5288-0  
Fax: +49 (0) 211 5288-143  
E-mail: info@hach-lange.de  
**www.hach-lange.com**



**Be Right™**