

Model OUS31 Turbidity Sensor



Installation and immersion sensor for drinking water and industrial water according to the 90° scattered light method



- Measuring range from 0.01 to 9999 FNU/NTU, 0.0 to 3.0 g/l, 0.0 to 3000 ppm
- Suitable as a drinking water sensor for every installation with a wall distance greater than 10 cm
- Commissioning without formazine, factory calibration ("plug and play")
- Measurement according to ISO 7027 / EN 27027
- Measurement under pressure to avoid degassing
- Direct installation in water pipes
- Wiper unit can be retrofitted
- Self-monitoring and plausibility check
- Integrated temperature measurement
- Inclined plain sensor surface uses medium flow to increase the self-cleaning effect and repels air bubbles
- Scratch-resistant sapphire glass measuring window
- Permissible distance between sensor and transmitter 200 m

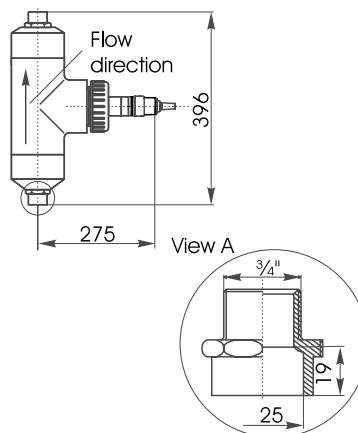

Flow assembly E

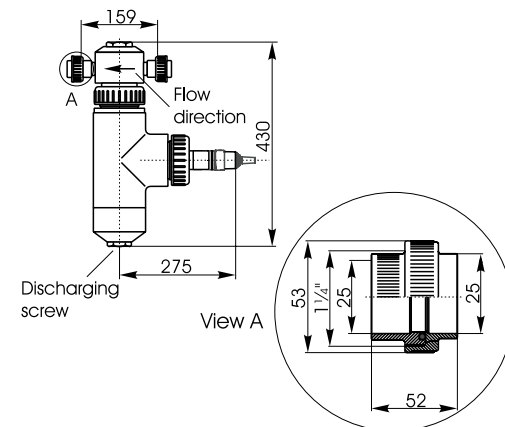

Flow assembly S with bubble trap

Measuring principle	Nephelometric 90° NIR scattered light
Measuring ranges	0.01 to 9999 FNU/NTU, 0.0 to 3.0 g/l, 0.0 to 3000 ppm (depending on sample type)
Wavelength	880 nm
Optical reference compensation	By reference photodiodes
Factory calibration	Formazine standard and SiO ₂
Temperature / pressure	6 bar (88 psig) at 25 °C (77 °F) 1 bar (14 psig) at 50 °C (122 °F)
Max. cable length	200 m
Temperature sensor	NTC Thermistor
Nominal operating range	-5 to 50 °C (23 - 122 °F)
Storage temperature range	-20 to 60 °C (-4 to 140 °F)
Ingress protection	IP 68
Sensor body	POM (Polyoxymethylene)
Optical windows	Sapphire

Specifications

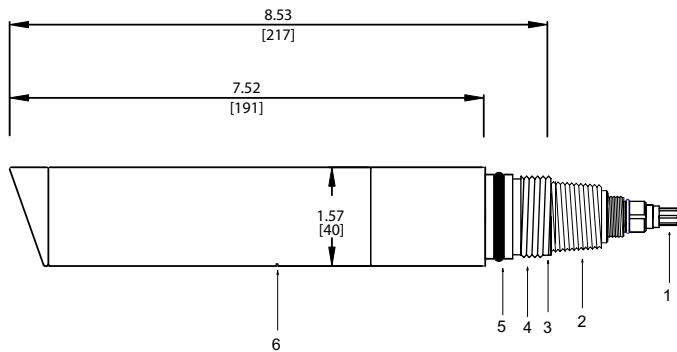

1. NEMA 6 waterproof connector
2. NPT 3/4" process mounting threads
3. Orientation markings
4. G 1" process mounting threads
5. O-ring Seal
6. POM Body

Dimensions Diagram

OVS31			
	Sensor Options		
	A	No wiper	
	W	With wiper	
	Cable Length		
	2	7 meters	
	4	15 meters	
	9	Connecting cable to customer's specifications	
	Assembly		
	A	Without assembly	
	E	Assembly for bubble-free media	
	S	Assembly with integrated gas bubble elimination	

Order Code

Part No.	Accessories
Replacement Kit	
50089252	Wiper, 3pc.
Installation Housings	
*OYA 611	Immersion
OYA 451	Retractable
OYA 120, OYA 250	Flow-through
* Not effective near wall - must use fixed pipe on wall with holder (OYY105)	

Accessories

Wedgewood Analytical, Inc.
 4123 East La Palma Avenue, Suite 200
 Anaheim, CA 92807
 Toll Free: 1-800-835-5474
 Direct: 1-714-577-5600
 Fax: 1-714-577-5688
www.WedgewoodAnalytical.com