

User Manual

User manual no.
LMI-16-09/05/12/A

**PRECISION
BALANCE
AS SERIES**

**PRECISION
BALANCE
AS/CT SERIES**



**MANUFACTURER
OF ELECTRONIC WEIGHING INSTRUMENTS**

RADWAG 26 – 600 Radom, Bracka 28, POLAND
phone +48 48 38 48 800, fax. +48 48 385 00 10
e-mail: export@radwag.com
www.radwag.com

MAY 2012

TABLE OF CONTENTS

1. TECHNICAL DATA	5
2. BASIC INFORMATION	7
2.1. Intended use.....	7
2.2. Inappropriate use.....	7
2.3. Warranty.....	7
2.4. Monitoring metrological parameters of the instrument.....	8
2.5. Data included in this user manual.....	8
2.6. Staff training	8
3. TRANSPORT AND STORAGE.....	8
3.1. Delivery check.....	8
3.2. Packaging.....	8
4. UNPACKING, ASSEMBLING AND STARTUP.....	9
4.1. Assembling, and place of use.....	9
4.2. Unpacking	10
4.3. Leveling.....	11
4.4. Standard equipment.....	12
4.5. Cleaning	12
4.6. Plugging to mains.....	12
4.7. Connecting peripheral devices	12
5. BASIC FUNCTIONS.....	12
6. KEYBOARD	14
7. START-UP	15
8. USER MENU.....	16
8.1. Moving through user menu.....	16
8.2. Return to weighing mode.....	18
9. WEIGHING.....	20
9.1. Selection of basic measuring unit.....	21
9.2. Temporary measuring unit.....	22
9.3. Setting accessibility of balance working modes.....	23
9.3.1. Selection of working modes available for a user.....	23
9.3.2. Means of selecting one of available working modes.....	25
10. BALANCE MAIN PARAMETERS.....	27
10.1. Setting level of filtering	27
10.2. Value release	28
10.3. Autozero function.....	29
10.4. Blanking of last digit on the display.....	30
10.5. Weighing mode RAPID.....	31
11. OTHER PARAMETERS.....	32
11.1. Backlight of weighing result (display backlight)	32
11.2. "Beep" sound – reaction on pressing a function key.....	33
11.3. Printout of all balance parameters through RS 232 port.....	33
12. BALANCE ADJUSTMENT	34
12.1. Internal adjustment.....	35
12.2. Settings of menu: Adjustment.....	37
12.3. Adjustment test.....	40
12.4. Manual adjustment.....	41

12.4.1. Internal adjustment	41
12.4.2. External adjustment	42
12.5. Adjustment report printout	43
13. DETERMINING CONTENT OF A PRINTOUT FOR GLP PROCEDURES	44
14. BALANCE WORKING MODES	47
14.1. Parts counting of the same mass	48
14.2. Checkweighing (HiLo) with reference to set standard	53
14.3. Percent setup	56
14.3.1. Reference mass determined by weighing	56
14.3.2. Reference mass set in balance memory by a user	57
14.4. Working mode FILL	59
14.5. Density determination of solids and liquids	60
14.5.1. Density determination of solids	61
14.5.2. Density determination of liquid	61
14.6. Pipettes calibration	62
14.6.1. Data input	62
14.6.2. First measuring series	63
14.6.3. Second measuring series	64
14.6.4. Third measuring series	65
15. RS 232 FUNCTIONS	67
15.1. Baud rate	67
15.2. Continuous transmission	68
15.2.1. Continuous transmission in basic measuring unit	68
15.2.2. Continuous transmission in current measuring unit	69
15.3. Setting operation mode for RS 232 interface	70
15.4. Determination of data type sent via RS 232 output	71
15.5. Minimum mass required for activating automatic printout	72
16. COOPERATION WITH A PRINTER OR A COMPUTER	73
16.1. Cross-section through connecting conductors	74
16.2. Printing date with specified date and time	75
16.3. Cooperation with statistic printer KAFKA SQS	75
16.4. Format of data sending	75
16.4.1. Format of data sent on pressing of PRINT key	76
16.4.2. Format of data sending as response to commands generated from a computer	76
17. UNDER HOOK WEIGHING	78
18. LIST OF COMMANDS: COMPUTER – BALANCE	79
19. ERROR MESSAGES	80
20. ADDITIONAL EQUIPMENT	81
20.1. Anti-vibration table	81
20.2. Rack for under hook weighing	81
20.3. Density determination kit (for solids and liquids)	81
20.4. Additional display	81
20.5. Computer software	82

1. TECHNICAL DATA

	AS 60/C/2	AS 60/220/C/2	AS 110/C/2	AS 160/C/2	AS 220/C/2	AS 310/C/2*
Max capacity	60g	60/220g	110g	160g	220g	310g
Minimum weight	1mg	1mg	10 mg	10 mg	10 mg	10 mg
Readability	0,01mg	0,01/0,1mg	0,1 mg	0,1mg	0,1mg	0,1mg
Tare range	-60g	-220g	-110 g	-160 g	-220 g	-310 g
Repeatability	0,04mg	0,04/0,1mg	0,1 mg	0,1 mg	0,1 mg	0,1 mg
Linearity	±0,07mg	±0,07/0,2mg	±0,2mg			±0,3mg
Pan size	Φ 70 mm		Φ 85 mm			
Sensitivity drift	1 ppm/°C in temperature +15 ° - +35 °C					
Working temperature	+10 ° - +40 °C					
Power supply	13,5 - 16V DC / 1,1 A					
Adjustment	internal (automatic)					
Display	LCD with backlight					

* - non-verified balance

	APS 120/C/2/CT	APS 220/C/2/CT	APS 320/C/2/CT
Max capacity	120g/600ct	220g/1100ct	320g/1600ct
Minimum weight	0,02g/0,1ct	0,02g/0,1ct	0,02g/0,1ct
Readability	0,0002/0,001ct	0,0002g/0,001ct	0,0002g/0,001ct
Tare range	-120g/-600ct	-220g/-1100ct	-320g/-1600ct
Repeatability	0,0002g/0,001ct		0,0004g/0,002ct
Linearity	±0,0002g/0,001ct		±0,0004g/0,002ct
Pan size	Φ 85 mm		
Sensitivity drift	2 ppm/°C in temperature +15 ° - +35 °C		
Working temperature	+10 ° - +40 °C		
Power supply	13,5 - 16V DC / 1,1 A		
Adjustment	internal		
Display	LCD with backlight		

Dimensions

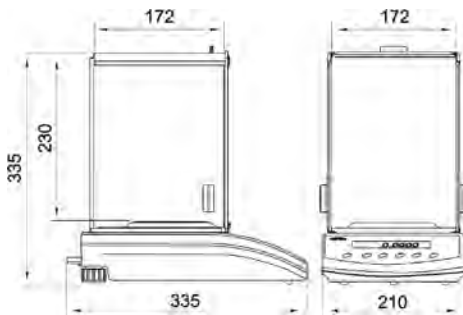

Balance series:

AS 60/C/2

AS 60/220/C/2

AS 110/C/2

AS 160/C/2

AS 220/C/2

AS 310/C/2

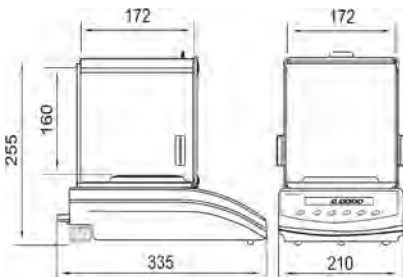

Balance series:

APS 120/C/2/CT

APS 220/C/2/CT

APS 320/C/2/CT

2. BASIC INFORMATION

2.1. Intended use

Analytical balance AS series serves to determine the weighing value of loads in laboratory environment. It is intended for application as a non-automatic weighing instrument only, i.e. the material to be weighed is manually and carefully placed in the center of the weighing pan. Weighing result should be read only after stable reading has been obtained.

2.2. Inappropriate use

Do not use the balance as a dynamic weighing instrument. Even if small quantities of weighed material are added or removed from the weighing pan of the instrument, the reading should be taken only after stabilization of the measurement result. Do not place any magnetic materials on the weighing pan, as this can cause damage of the measuring system of the instrument. Be sure to avoid impact shock and overloading the balance in excess of the prescribed maximum measuring range (max capacity), minus any possible tare weight that has been applied. Never use the balance in an environment endangered by an explosion. This balance has not been adjusted for operation in explosive areas. There must not be any modification made to the balance.

2.3. Warranty

Warranty is not valid at the following:

- Non-observation of the guidelines of this user manual,
- Use of balance other than specified in this manual,
- Alternation to or opening of the device,
- Mechanical damage and damage caused by media, natural water, and tear,
- Inappropriate assembling or defects of electric installation,
- Overloading of the measuring instrument.

2.4. Monitoring metrological parameters of the instrument

Metrological characteristics of the balance requires periodical inspection carried out by its operator. Inspection frequency is conditioned by ambient conditions in which the balance is used, types of performed processes and accepted quality management system in an organization.

2.5. Data included in this user manual

Please read the user manual carefully before assembling and startup, even if the user is experienced with this type of weighing instruments.

2.6. Staff training

This balance should only be operated and maintained by personnel who is trained and experienced in using this type of balances.

3. TRANSPORT AND STORAGE

3.1. Delivery check

Please check the packaging immediately upon delivery and the device during unpacking for any visible signs of external damage.

3.2. Packaging

Please retain all parts of the original packaging should the balance be transported in the future. Only the original packaging should be used for dispatching the balance. Before packing, disconnect all attached cables and remove any loose/movable parts (weighing pan, anti-draft shields, etc.). Please place balance and its components in their original packaging, and protect them against damage during transport.

4. UNPACKING, ASSEMBLING AND STARTUP

4.1. Assembling, and place of use

- Balance should be stored and used in locations free of vibrations and shakes, free of air movement and dust,
- Ambient air temperature should not exceed the range of: $+10^{\circ}\text{C} \div +40^{\circ}\text{C}$
- Ambient relative humidity should not exceed 80%
- During balance operation, ambient temperature in the weighing room should not change more than $0,5^{\circ}\text{C}$ within one hour,
- The balance should be located on a stable wall console desk or a stable working table which is not affected by vibrations and distant from heat sources,
- Take special safety measures when weighing magnetic objects, as part of the balance is a strong magnet. Should such loads be weighed, use under hook weighing option, which removes the weighed load from area influenced by the balance's magnet. For assembling the hook for under hook weighing option see the bottom section of balance's housing,
- In order to avoid influence of static electricity on the measurement process, ground the balance's housing. the grounding bolt is located at the back of balance's housing.

4.2. Unpacking

Carefully remove the balance from its packaging, remove the plastic and foil transport protective elements and gently place the balance in its intended place of use. Assemble the weighing pan, and other elements according to below scheme:

Balance with weighing pan Φ 70 mm:

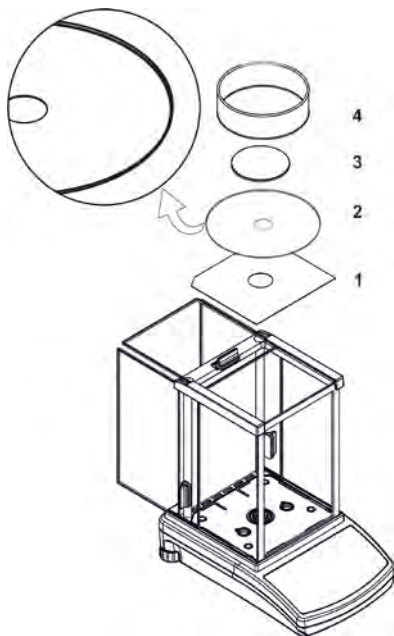

- open side doors of the weighing chamber,
- inside the weighing chamber place lower shield of the weighing chamber (1),
- put centering ring (2) [framing facing downwards] onto the weighing chamber's shield,
- in the center of centering ring assembly the weighing pan (3),
- assembly anti-draft shield (4) on the centering ring and weighing chamber's shield,
- close side doors of the weighing chamber,
- plug the balance to mains, pin of power adaptor should be connected to socket in the back of balance housing.

Balance with weighing pan Φ 85 mm:

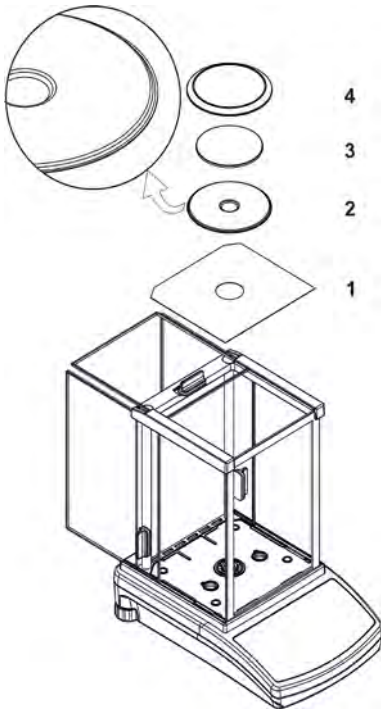

- open side doors of the weighing chamber,
- inside the weighing chamber place lower shield of the weighing chamber (1),
- put centering ring (2) [framing facing downwards] onto the weighing chamber's shield,
- in the center of centering ring assembly the weighing pan (3),
- assembly anti-draft shield (4) inside the weighing chamber,
- close side doors of the weighing chamber,
- pin of power adaptor should be connected to socket in the back of balance housing.

4.3. Leveling

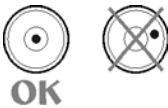

Before plugging to mains, level the device using two adjusting feet located at the back of balance's housing. Turn the adjusting feet in a way that the air bubble of the level is placed centrally. The level is located at the back wall of balance's housing.

4.4. Standard equipment

- Balance.
- Weighing pan and protecting (anti-draft) components.
- Power adapter.
- User manual.

4.5. Cleaning

Balance should be cleaned with damp cloth by gentle wiping the smudges of dirt. In order to clean the weighing pan of the balance, please remove it from the weighing chamber. **Cleaning of the pan when assembled may cause damage of the measuring system of the balance.**

4.6. Plugging to mains

Balance can be plugged to mains only with a power adapter that comes standard with the balance. Nominal power supply of the power adapter (specified on the data plate of the power adapter) should be compatible to the power from mains. Plug the balance to mains – the plugging socket is located at the back of balance's housing. Balance display will light and show name and number of software, after which balance will display 0.0000g. If indication is other than zero, please press **ESC/TARE** key.

4.7. Connecting peripheral devices

The balance must be unplugged from the mains before connecting or disconnecting any peripheral devices (printer, PC computer). Use only peripheral devices recommended by the manufacturer with your balance. These have been ideally coordinated to your balance. On connecting a peripheral device, plug the balance to mains.

5. BASIC FUNCTIONS

- **functions related to measuring units**
 - setting default measuring unit **<StUn>**,
 - weighing in grams [g],
 - weighing in milligrams [mg],
 - weighing in carats [ct],
 - weighing in units from beyond **SI** (available only in non-verified balances): [oz], [ozt], [dwt], [t], [mom], [gn],

- **functions related to working modes**
 - parts counting <PcS>,
 - checkweighing (+/- control) <HiLo>,
 - percent setup <PrcA>, <PrcB>,
 - density determination of liquid <d_Li>,
 - density determination of solids <d_Co>,
 - pipettes calibration <PIPEt>
 - FiLL mode <FiLL>

- **functions related to setting a balance to ambient and working conditions at a workstation**
 - enabling / disabling autozero system <Auto>,
 - setting the parameter of measurement result averaging <AuE>,
 - measurement result value release <ConF>,
 - weighing mode <rAPd>,
 - display backlight <bl>,
 - beep signal (balance reaction on pressing a function key) <bEEP>,

- **functions related to use of RS 232 interface**
 - setting baud rate <bAud>,
 - Continuous data transmission in basic measuring unit <CntA>,
 - Continuous data transmission in current measuring unit <Cntb>,
 - Automatic operation mode <rEPL>.

Balance As series can be used to weigh loads under the weighing platform – i.e. under hook weighing option.

Balance software enables printing a report from adjustment process and carrying out adjustment test.

6. KEYBOARD

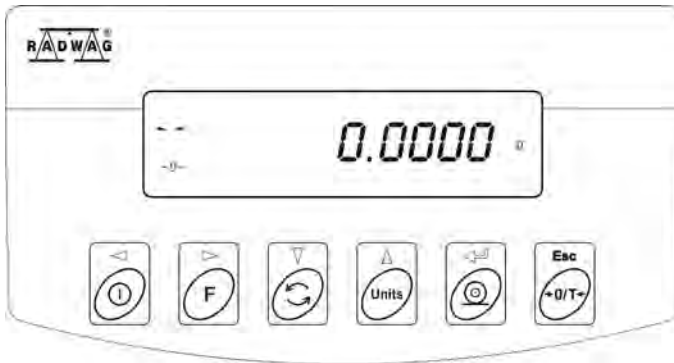

ON/OFF key; enables turning on and off balance's display. If turned off, balance components other than the display are powered, and balance is in stand-by mode.



F key; function key.



MODE key; for selecting working mode.



UNITS key; changes measuring units.



PRINT/ENTER key; sends current display status to a peripheral device (PRINT) or accepts selected value of a parameter or function (ENTER).



ESC/TARA key; zeroing display indication.

7. START-UP

When plugged to mains, the balance displays name and number of software, and afterwards proceeds to weighing mode.

Balance temperature stabilization period.

Before start of measuring processes, it is necessary to wait until the balance is thermally stabilized. It is a period of so called balance self-heating. In case of balances AS and APS series self-heating period takes approximately 30 minutes. The specified time interval refers to balances that have been stored in room temperature before plugging to mains.

For balances that were stored in much lower temperatures before plugging to mains (e.g. during winter period) thermal stabilization should last approximately 4 hours.

Correct operation of a balance is possible within temperature range specified in the technical parameters, see point 1. If the balance is placed in area which ambient temperature is out of temperature range specified in the technical data, then balance's display may signal such situation by lighting an appropriate marker (a black triangle).









In case the balance displays the marker, increase or decrease ambient temperature, depending on present temperature value. It is recommended that ambient temperature changes at balance's place of use are very small (slow).

8. USER MENU

Balance menu is divided into **7** basic function groups. Each group has individual name starting with capital letter **P**.

8.1. Moving through user menu

An operator moves through balance menu using keys on overlay's keyboard:

	Entering main menu. F function key.
	Selecting group of parameters one by one downwards or changing parameter value by one value downwards. MODE key.
	Selecting group of parameters one by one upwards or changing parameter value by one value upwards. UNITS key.
	Selecting group of parameters for activating. On pressing the key, the display indicates the first parameter in a selected group. F key.
	Exit to previous menu level, e.g. to the main menu. ON/OFF key.
	Abandon parameter changes. Esc/TARE key.
	Accept / confirm introduced changes. PRINT/ENTER key.

Name of function groups and their content:

P1 CAL	[Adjustment/Calibration]
P1.1 iCAL	[internal adjustment]
P1.2 ECAL	[external adjustment]
P1.3 tCAL	[temperature adjustment]
P1.4 ACAL	both/nonE/tenno/tinnE [automatic adjustment]
P1.5 CALt	1 h ÷ 12h [time of automatic adjustment]
P1.6 CALr	YES/no [report from adjustment]

P2 GLP	[Good Laboratory Practice]	
P2.1 USr	–	[name of user]
P2.2 PrJ	–	[name of project]
P2.3 Ptin	YES/no	[printout of measurement time]
P2.4 PdAt	YES/no	[printout of measurement date]
P2.5 PUSr	YES/no	[printout of user name]
P2.6 PPrJ	YES/no	[printout of project name]
P2.7 PId	YES/no	[printout of balance's factory number]
P2.8 PFr	YES/no	[printout of frames]

P3 rEAd	[Main user parameters]	
P3.1 AuE	Stand/Slouu/FASt	[filtering level]
P3.2 ConF	FASt_rEL/Fast/rEL	[value release]
P3.3 Auto	On/OFF	[autozero]
P3.4 Ldi9	ALuuAYS/neper/uu_StAb	[blanking last digit]
P3.5 rAPd	YES/no	[weighing mode RAPID]

P4 Print	[Data transmission – RS 232]	
P4.1 bAud	2400/4800/9600/19200	[baud rate]
P4.2 CntA	YES/no	[continuous printout in basic measuring unit]
P4.3 Cntb	YES/no	[continuous printout in current measuring unit]
P4.4 rEPL	YES/no	[manual or automatic operation]
P4.5 PStb	YES/no	[measurement result printout: stable or unstable]
P4.6 Lo	000.0000	[min mass threshold for automatic operation]

P5 Unit	[Measuring units]	
P5.1 StUn	g/mg/ct/oz/ozt/dwt/t/mom/G	[basic measuring units – e.g, gram]
P5.2 mg	YES/no	[mg - milligram]
P5.3 Ct	YES/no	[ct – carat]
P5.4 oZ	YES/no	[oz – ounce]
P5.5 oZt	YES/no	[ozt – ounce troy]
P5.6 dwt	YES/no	[dwt – pennyweight]
P5.7 t	YES/no	[t – tael]
P5.8 nno	YES/no	[mom - momme]
P5.9 Gr	YES/no	[gr – grain]

P6 Func	[Funkcje]	
P6.1 FFun	ALL/PcS/HiLo/PrcA/PrCb/d_Co/d_Li/PipEttE/FiLL	[working mode selection]
P6.2 PcS	YES/no	[parts counting]

P6.3	HiLo		YES/no	[checkweighing]
P6.4	PrcA		YES/no	[percent setup with reference to weighed standard]
P6.5	Prcb		YES/no	[percent setup with reference to declared standard]
P6.6	d_Co		YES/no	[density determination of solids]
P6.7	d_Li		YES/no	[density determination of liquids]
P6.8	Pi_t		YES/no	[pipettes calibration]
P6.9	Fill		YES/no	[working mode FILL]

P7	othEr			[Other functions]
P7.1	bL		On/Aut/OFF	[display backlight]
P7.2	bEEP		On/OFF	[beep sound on pressing keys]
P7.3	PrnS			[printout of balance parameters]

8.2. Return to weighing mode

CAUTION



Changes introduced in balance memory will be permanently saved on return weighing with procedure of saving changes.

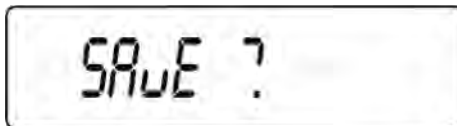

Press **ESC/TARE**  key for several times, until the display indicates command **SAVE?**.



Then select one of below option:

- **PRINT/ENTER**  key – save (accept) changes
- or **ESC/TARE**  key – abandon introduced changes, and leave to balance menu.

After pressing an appropriate key, the balance goes back to weighing mode.

9. WEIGHING

Before start of weighing process or in case of essential change of ambient conditions at a workstation (e.g. ambient temperature change at a workstation more than 0,8°C) the balance requires adjusting. The procedure of balance adjustment is described further in this user manual.

- Before start of weighing procedure, it is recommended to load the balance's weighing pan a few times with mass close to balance max capacity,
- Check if unloaded balance indicates "precise zero" - **0** - and whether measurement is stable - **▲▲**, if not press **ESC/TARE** key,
- Press **UNITS** key to set a measuring unit: [g], [mg], [ct], and also if enabled in factory menu [oz], [ozt], [dwt], [t], [mom], [gn],
- place weighed object on balance's weighing pan and read result only on stabilization of measurement result,
- mass indication of a load placed on balance's weighing pan can be tarred for multiple times by pressing **ESC/TARA** key (pay attention not to exceed maximal capacity of a balance by applying multiple tare function).

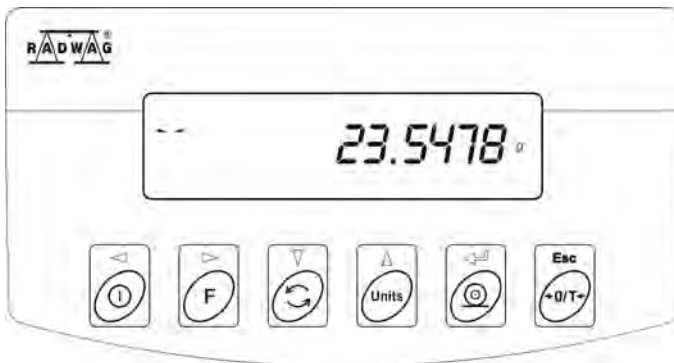

During times between carrying out the following measurement series do not unplug the balance from mains. It is recommended to switch off balance's display by pressing **ON/OFF** key. On repeated pressing of the **ON/OFF** key the balance is ready for operation and carrying out the following measurements.



In order to adjust the balance's operation (while weighing small mass $\leq 0,6g$) to ambient conditions at a workstation, it is recommended to set the following:

- filtering level AuE to: the slowest

- value release ConF to: reliable

9.1. Selection of basic measuring unit

Function is used to set the measuring unit which will be displayed on balance switching on.

In order to set the measuring unit go to submenu **P5 Units**

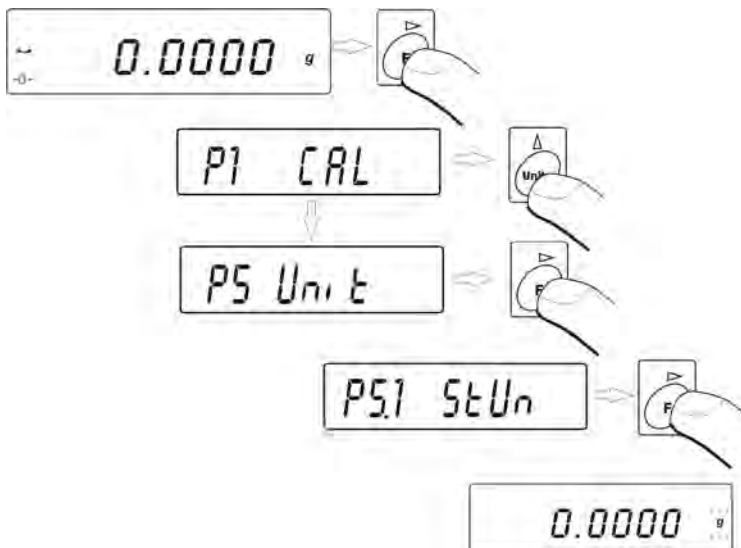

press **UNITS** key for a few times. The display indicates available measuring units in turns.

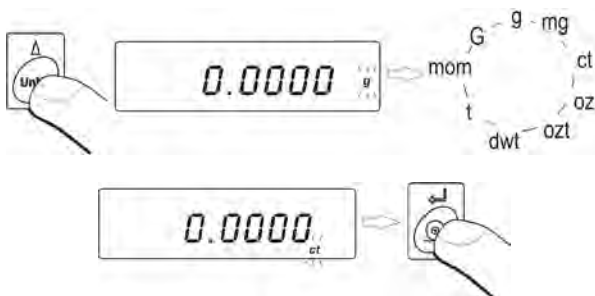

After selecting the basic measuring unit press **PRINT** key. The balance returns to displaying parameter name.

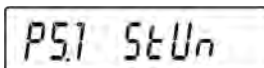

Available settings:

- For verified balances, a user can select from the following measuring units: [g], [mg], [ct];
- For non-verified balances, a user can select from the following measuring units: [g], [mg], [ct], [oz], [ozt], [dwt], [t], [mom], [gn].

Go back to weighing mode with procedure of saving changes
(see point - 7.1.2. – return to weighing).



CAUTION:

On switching on, the balance will start operating with set basic measuring unit.

9.2. Temporary measuring unit

Function enables selecting a measuring unit which will be indicated next to mass readout during weighing process. Set measuring unit will be in use from the moment of its activation until its change or switching off and on the balance. Each pressing the **Units** key, causes change of the measuring unit.

Available settings:

- For verified balances, a user can select from the following measuring units: [g], [mg], [ct];
- For non-verified balances, a user can select from the following measuring units: [g], [mg], [ct], [oz], [ozt], [dwt], [t], [mom], [gn].

9.3. Setting accessibility of balance working modes

This group of parameters enables the user to declare functions (working modes) which are accessible on pressing of **MODE** key.

Enter group of parameters **P6 Func**,

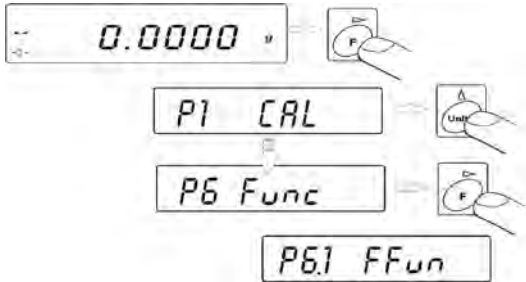

9.3.1. Selection of working modes available for a user

Function enables selecting (by pressing **MODE** key) which working modes are accessible during weighing function – if all – then select (ALL) and if only one from all available (described below).

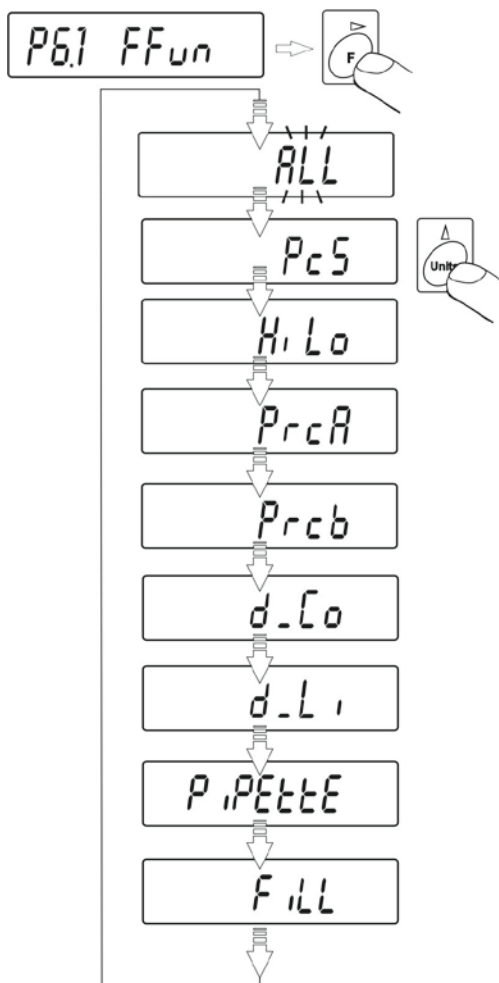

After setting the parameter press **PRINT** key. Balance goes back to displaying submenu name **P6.1 FFun**.

If a mode other than **ALL** is selected, procedure of returning to weighing mode differs from other ones.

If for instance **PcS** mode is selected, follow procedure in accordance with point 14.1 point, to return to weighing:

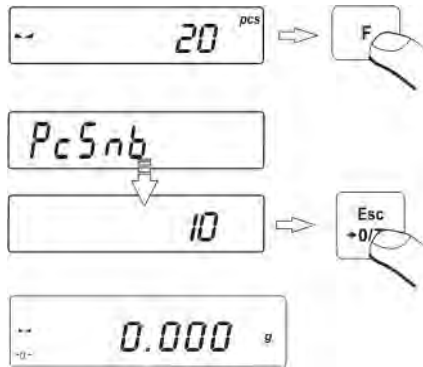

Press **Esc/TARE** key, balance returns to weighing.

9.3.2. Means of selecting one of available working modes

Balance user can enable or disable modes which are not used in the weighing process. This provides quicker access to modes used on a balance.

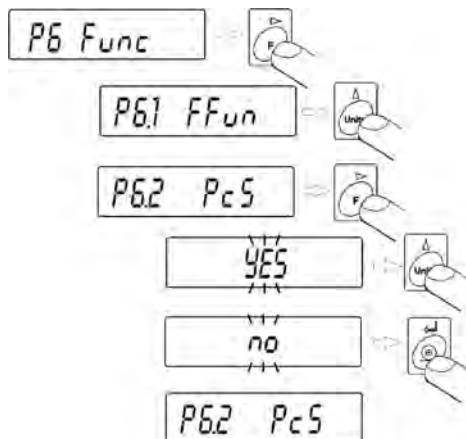

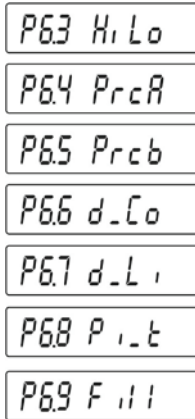

YES - mode available;
no - mode disabled

On making a choice press **PRINT** key. The balance returns to displaying submenu name.

Go back to weighing mode with procedure of saving changes
(see point - 7.1.2. – return to weighing).

10. BALANCE MAIN PARAMETERS

It is possible to adjust balance's operation to ambient conditions at a workstation (by setting filter range and value release parameters) or user requirements (autozero settings, last digit visibility). These parameters are set in group **P3 rEAd**.

10.1. Setting level of filtering

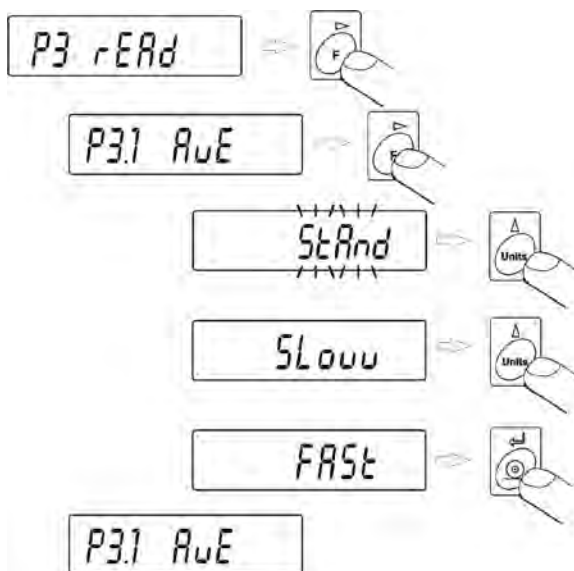

- using **UNITS** key to select desired value of filter settings,

- | | |
|--------------|--|
| StAnd | - (normal) – normal operation conditions |
| SLoUu | - (slow) – harsh operation conditions - vibrations, etc. |
| FRSt | - (fast) – good operation conditions – no vibrations, etc. |

Return to weighing mode with procedure of saving changes

(see point – 8.2. – return to weighing).



CAUTION:

The higher filtering setting the longer weighing time.

10.2. Value release

Due to various ambient conditions at workstations, and in order to set balance to present conditions, it is necessary to determine the value release parameter as: **FAST_rEL**, **Fast** or **rEL**. Depending on selected option, weighing time will be shorter or longer.

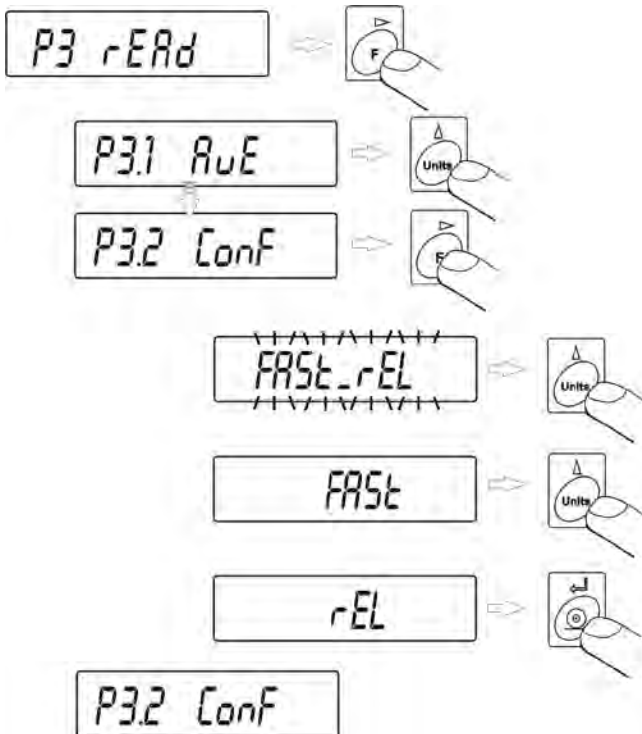

Fast_rEL - fast + reliable
Fast - fast
rEL - reliable.

Return to weighing mode with procedure of saving changes

(see point - 8.2. - return to weighing).

10.3. Autozero function

In order to ensure balance's precise mass indication, autozero (**Auto**) software parameter has been introduced. The application of this function is automatic control and correction of zero indication. When function is enabled, it compares balance indications at declared time interval e.g. 1 s, on conditions that weighing pan is unloaded and display indication is close to zero. If results vary less than declared AUTOZERO range e.g. one division, balance will zero automatically, display marker of stable measurement result \blacktriangleleft and precise zero marker $\Rightarrow 0 \Leftarrow$.

If AUTOZERO function is enabled, then each weighing process starts from precise zero point. There are, however, some cases when this function can be a disturbing factor of measuring process; for instance very slow placing of load on the weighing pan (e.g. load pouring) – in such case system of zero indication correction can also correct actual indication of loaded mass.

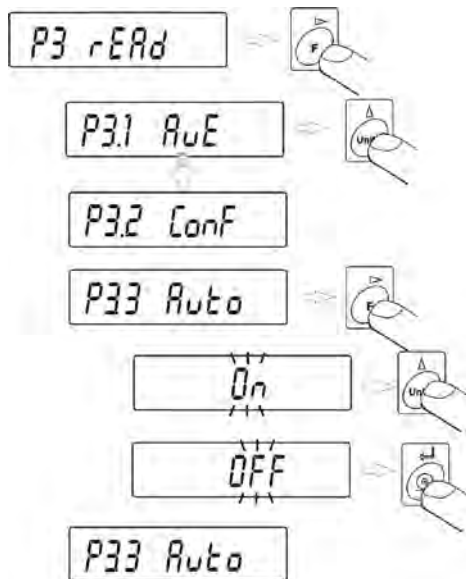

- OFF** – autozero disabled
- On** – autozero enabled.

Return to weighing mode with procedure of saving changes
(see point - 8.2. - return to weighing).

10.4. Blanking of last digit on the display

Function enables blanking of the last displayed digit.

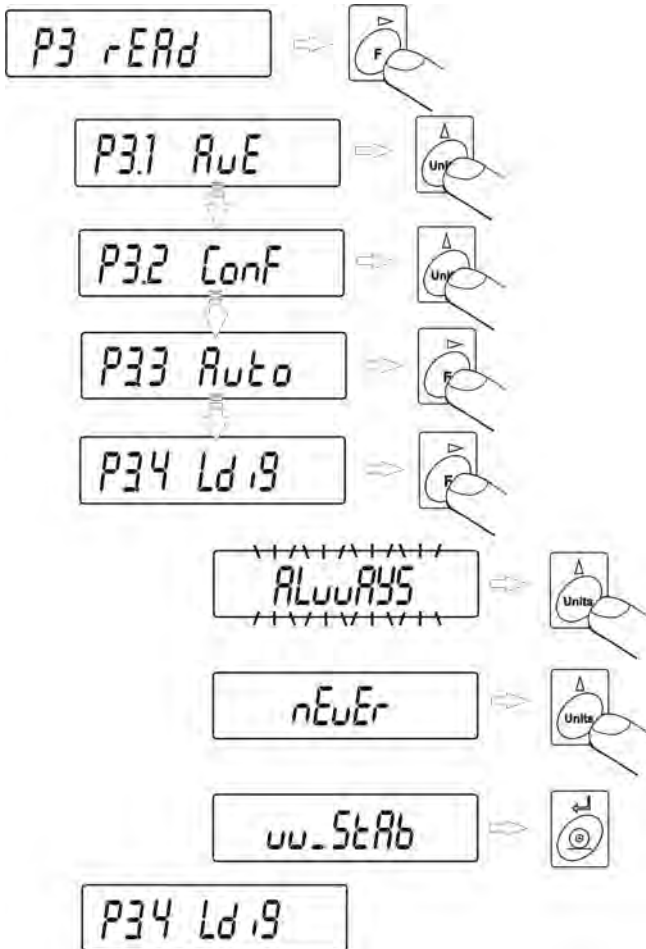

- ALuAYS** – always
- nEuEr** – never
- uu_StAb** – when measurement result is stabilized.

Return to weighing mode with procedure of saving changes

(see point - 8.2. - return to weighing).

10.5. Weighing mode RAPID

Weighing mode RAPD is located in menu parameter P3.rEAd and it offers two options:

RAPID = NO – balance operates with settings as set in menu AUE and CONF, i.e. standard weighing.

RAPID = YES – (default settings) balance operates with settings specific for software mode “FILL”, and:

- The value of CONF parameter is automatically set to: Fast+rel, independently on previous setting of this parameter;
- The value of AuE parameter is automatically set to: Standard, independently on previous setting of this parameter;
- The value of Stabilization time parameter is automatically decreased (factory setting is decreased by 4). Such parameter setting speeds up the time of stability pictogram ▲ appearance on the display.

The values of AuE and CONF parameters are editable if mode rAPd is enabled for setting shorter or longer measurement time.

Mode enabling or disabling

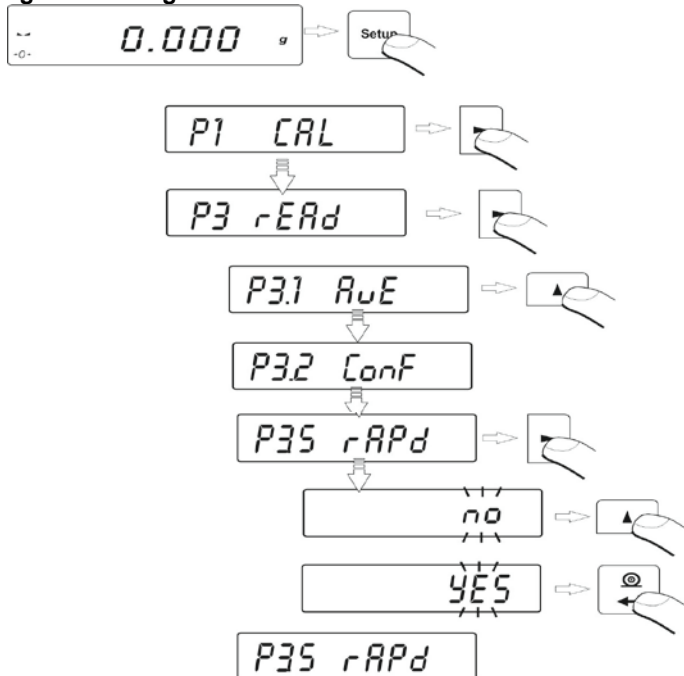

Return to weighing mode with procedure of saving changes

(see point – 8.2. – return to weighing).

11. OTHER PARAMETERS

Balance AS series features a set of parameters which enable influencing its functionality. The parameters are contained in group: **P7 other** and they are: backlight and “beep” signal and printout of all balance parameters through RS 232 port.

In order to edit the above parameters enter menu group **P7 Other**.

11.1. Backlight of weighing result (display backlight)

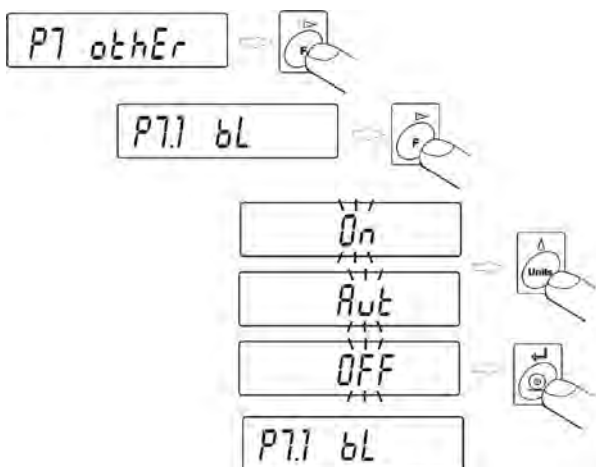

- OFF** – backlight disabled
- On** – backlight enabled
- Aut** – backlight disabled automatically if weighing result does not change within 10 seconds.

Return to weighing mode with procedure of saving changes

(see point – 8.2. – return to weighing).

CAUTION:

Balance software has implemented option of automatic backlight switch off **bl = Aut**. In case of this setting, the backlight is switched automatically off if weighing results does not change within 10 seconds. Backlight is automatically activated at the moment of weighing result change on balance display



11.2. "Beep" sound – reaction on pressing a function key

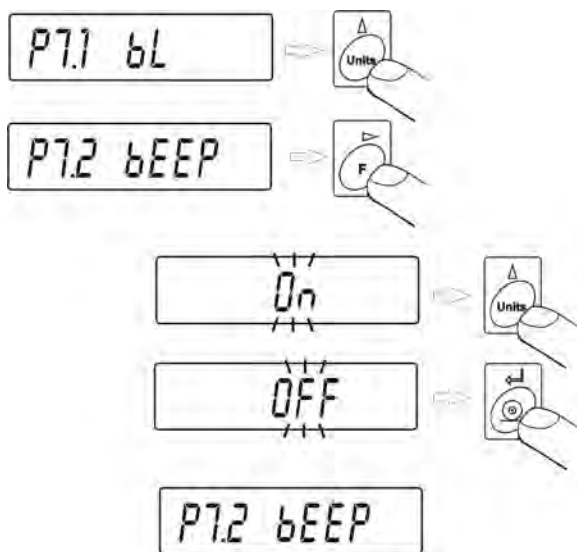

- OFF** – signal of pressing function key disabled
- On** – signal of pressing function key enabled.

Return to weighing mode with procedure of saving changes
(see point – 8.2. – return to weighing).

11.3. Printout of all balance parameters through RS 232 port

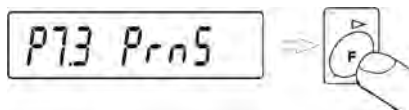

After pressing **F** key balance parameters are sent to a peripheral device connected to balance's RS 232 port.

Return to weighing mode with procedure of saving changes
(see point – 8.2. – return to weighing).

12. BALANCE ADJUSTMENT

As the gravitational acceleration force has different value at various latitudes and altitudes, a balance should be adjusted to present working conditions. This process should take place at the first installation of the instrument on site and at its every re-location – as in case of ambient temperature changes.

In order to ensure the highest weighing accuracy, it is recommended to periodically introduce to balance memory a corrective factor of indications in relation to a mass standard – i.e. balance adjustment.

Adjustment should be carried out:

- Before the beginning of weighing procedure,
- If long breaks between following measuring series occur
- If temperature inside the balance changes more than: 0,8°C.

Types of adjustment:

- Internal automatic adjustment
 - * triggered by temperature change
 - * triggered by elapsing time
- Manual internal adjustment
 - * initiated from balance's keyboard
- Adjustment with external weight
 - * with declared mass which cannot be modified.



CAUTION

In case of verified balances (with internal automatic adjustment system) only the automatic internal adjustment and manual internal adjustment system are available for a user.

In verified balances PS series with external adjustment system, adjustment process is blocked (not available) for a user.



Perform the calibration when there is no load on the pan!

*Remember to carry out adjustment process only when there is no load on the weighing pan! In case there is load on the weighing pan, the display will indicate a command **Er1 Hi**. It is comment of unloading the pan. Adjustment process can be aborted if necessary by pressing **Esc/TARE** key.*

12.1. Internal adjustment

Adjustment process can be initiated automatically or manually.

Manual means of activating adjustment procedure is realized by pressing **F** key on balance's keyboard. System of automatic adjustment will carry out the process fully automatically inform the operator on successive process stages.

Cycle of automatic adjustment process:

- balance software detects necessity of carry out adjustment and signalizes it by Celsius degree pictogram or by black colour pictogram on balance display

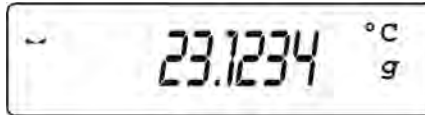

- since pictogram occurrence, time interval of 5 minutes is counted within which weighing procedure can be completed
- as the 5 minutes time elapses, balance display indicates message **CAL_30** and starts counting down from 30..29..28 to 0 (indicated value is the counter),



- balance user has 30 seconds to make a decision:
 - in order to start adjustment, do not take any actions
 - in order to complete weighing procedure, press **ESC/TARE** key, If pressed, balance returns to weighing procedure and displays last weighing result. In 5 minutes balance will again indicate **CAL_30** message.
- the adjustment process can be postponed for multiple times, but it needs to be stressed that long postponing of adjustment may be a reason of bigger errors of weighing process. The errors are effect of temperature changes and as a consequence changes of balance sensitivity.

Automatic adjustment process takes place in three different cases:

- adjustment on plugging the balance to mains. After approximately 6 minutes from plugging the balance to mains, it automatically initiates adjustment process.
- Balance AS series is equipped with very precise system for monitoring temperature. At each adjustment process, the temperature is saved in system. The next adjustment is automatically initiated if temperature changes more than: 0,8°C from last saved temperature in case of balance AS series,



- adjustment triggered by elapsing time. It is possible to declare time intervals which are a criteria for balance adjustment. Accessible settings are: adjustment after 1, 2, 3, 4, 5, 6, 7, 8, 9, 10, 11, 12 hours since last carried out adjustment procedure.



CAUTION

Declaring time interval for balance adjustment is available only in non-verified balances. In case of verified balances the time interval between following adjustments is set for 3 hours

12.2. Settings of menu: Adjustment

P1 CAL

P1.1	iCAL		
P1.2	ECAL		
P1.3	tCAL		
P1.4	ACAL		both
P1.5	CALt		1 h
P1.6	CALr		YES

- **P1.1 iCAL – Internal adjustment**

Start of internal adjustment process. Adjustment is conducted automatically, and no operator assistance is required. If weighing pan of the balance is loaded, balance will display a command to unload the weighing pan. If weighing pan is loaded with relatively small mass (up to 4 % of balance max capacity) than adjustment process will be carried out automatically, but measuring results may differ by the amount that was present on balance weighing pan.



- **P1.2 ECAL - External adjustment (with an external weight)**

Adjustment with external weight, which value is saved in factory menu of balance, function unavailable in verified balances.



- **P1.3 tCAL – Adjustment test**

Mass comparison of internal adjustment weight with its value saved in balance memory.



- **P1.4 ACAL – Automatic adjustment**

Determination of factor, which conditions start of automatic internal adjustment.

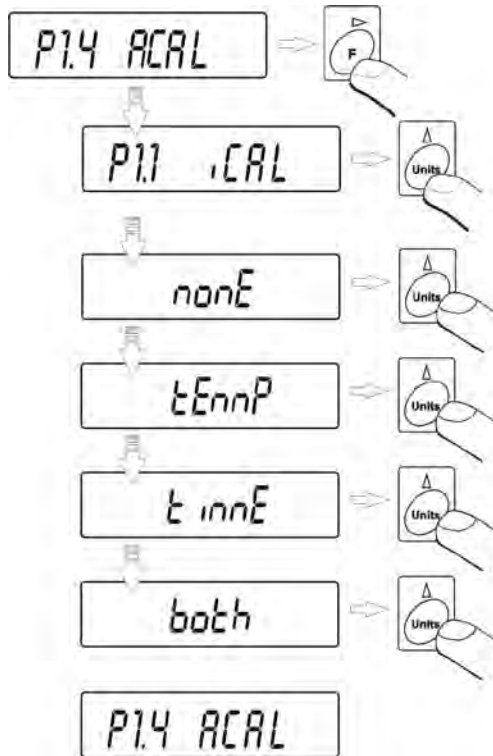

- nonE** - none of factors will cause start of adjustment
- tEmP** - adjustment triggered by change of temperature
- timE** - adjustment triggered by time interval set in parameter **P1.5 CALt**
- both** - adjustment triggered by time and temperature.

- **P1.5 CALt - Time of automatic adjustment (balances with internal adjustment system)**

Determination of time interval, after which automatic adjustment process is initiated.

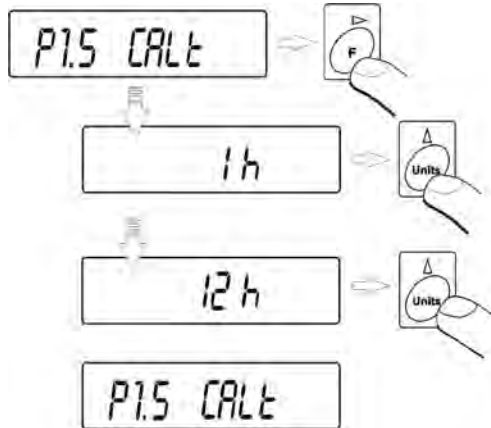

- **P1.6 CALr – printout of adjustment report**

Printout activated on completion of automatic adjustment procedure.

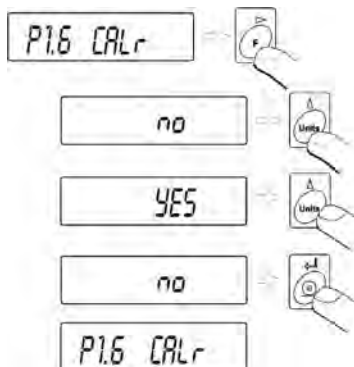

- no** – report printout disabled
- YES** – report printout enabled.

Return to weighing mode with procedure of saving changes
(see point – 8.2. – return to weighing).

12.3. Adjustment test

Adjustment test is a comparison of internal adjusting weight with its value stored in balance's memory. This process is automatic and its result is shown on the display (if a balance is connected to a computer or a printer through RS 232 socket, data on adjustment test is printout). Press **ESC/TARE** key to return to previous display.

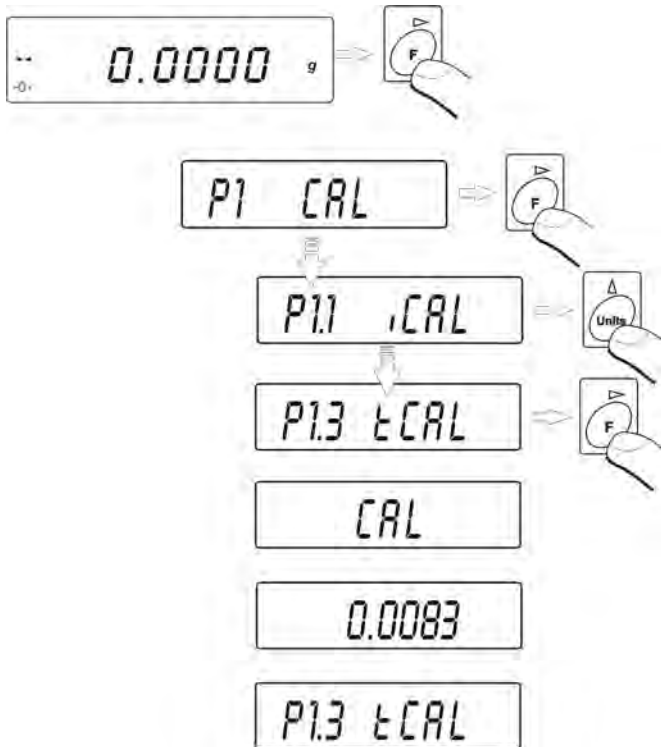

Return to weighing mode with procedure of saving changes
(see point – 8.2. – return to weighing).

12.4. Manual adjustment

12.4.1. Internal adjustment

Press **F** function key for three (3) times.

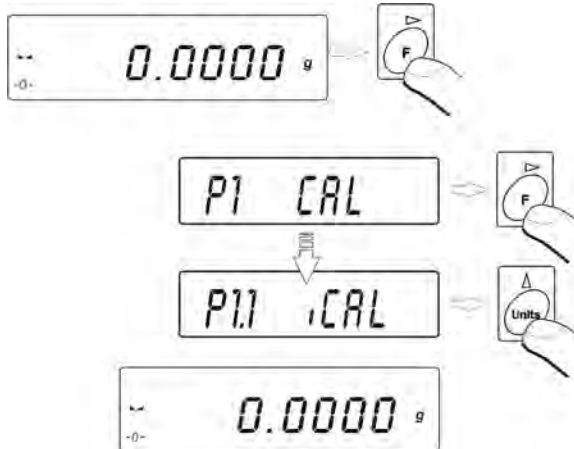

The balance automatically enters internal adjustment mode. During adjustment process do not load the weighing pan with any load. On completion of adjustment process, balance saves its result in memory and returns to weighing mode.

CAUTION:



- Press **ESC/Tare** key to abort adjustment process
- If during adjustment process, weighing pan of a balance is loaded, than balance display will show order informing on error occurrence. Adjustment process will be stopped. As weighing pan is unloaded, the adjustment process will continue and complete.

12.4.2. External adjustment

The external adjustment in balances AS series should be carried out with an external mass standard / weight class E₂.

Start of external adjustment process,

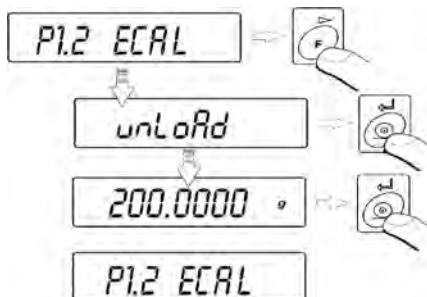

Balance will display a command ordering unloading of weighing pan **unLoAd** (weighing pan should be empty). When weighing pan is unloaded, press **PRINT** key. The balance determines mass of empty pan. Place an external adjustment weight with mass determined on balance's display and press **PRINT** key. On completing adjustment process the balance returns to submenu **P1.2 ECAL**.

Return to weighing mode with procedure of saving changes

(see point - 8.2. - return to weighing).



If a balance is verified, then user does not access to carrying out external adjustment process.

12.5. Adjustment report printout

On completion of any type of adjustment process, the balance enables preparing a report from adjustment process. The report can be printed on a connected printer and sent to a computer and saved in a form of file for records. Printout process is described in details in point 9.2 of this user manual. The user can select between two options.

- no** – report is not printed
- YES** – report is printed

Remember, that if the parameter is set for **YES**, then a report is generated and sent automatically.

Content of report from adjustment process depends on settings of GLP parameters. Any option in the GLP submenu which attribute is YES is included in a report from adjustment process.

P2 GLP (Good Laboratory Practice)

P2.1	uSr		
P2.2	PrJ		
P2.3	Ptin		YES
P2.4	PdAt		YES
P2.5	PuSr		YES
P2.6	PPrJ		YES
P2.7	PId		YES
P2.8	PFr		YES

Apart from information set in menu group the report contains:

- Mass of adjustment weight stored in balance's memory from last carried out adjustment;
- Mass of adjustment weight determined in current adjustment process;
- Adjustment deviation, i.e. difference between the two mass records.

```
*** Automatic calibration report ***
Date   : 09/02/2007
Time   : 11:21:39
User Id : 12345678
Project Id: 87654321
Balance Id: 114493

Calibr. : Automatic
Difference: - 0.0002 g

Name .....
```

13. DETERMINING CONTENT OF A PRINTOUT FOR GLP PROCEDURES

P2 GLP, is group of the parameters which enables declaring variables that are present on an adjustment printout and printout activated after a measurement.

P2 GLP

P2.1	USr		
P2.2	PrJ		
P2.3	Ptin		YES
P2.4	PdAt		YES
P2.5	PUSr		YES
P2.6	PPrJ		YES
P2.7	Pld		YES
P2.8	PFr		YES

- **P2.1 USr**

The parameter enables determining name of a operator who works with the balance. User name contains maximally 8 alphanumeric characters. The name is inserted using **F**, **MODE**, **UNITS** on balance's keyboard and **PRINT** key.

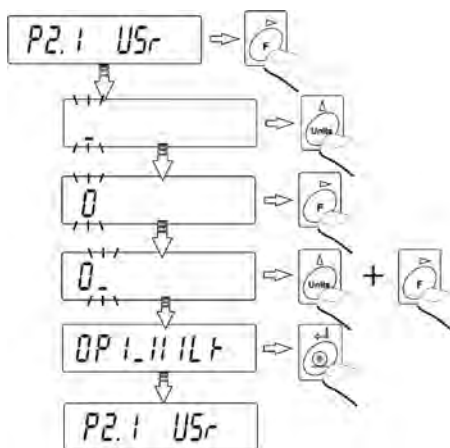

Accessible characters and their equivalents displayed by the balance:

-	0	1	2	3	4	5	6	7	8	9		
0	1	2	3	4	5	6	7	8	9			
A	B	C	D	E	F	G	H	I	J	K	L	M
A	B	C	D	E	F	G	H	I	J	K	L	M
N	O	P	Q	R	S	T	U	V	W	X	Y	Z
N	O	P	Q	R	S	T	U	V	W	X	Y	Z
a	b	c	d	e	f	g	h	i	j	k	l	m
a	b	c	d	e	f	g	h	i	j	k	l	m
n	o	p	q	r	s	t	u	v	w	x	y	z
n	o	p	q	r	s	t	u	v	w	x	y	z

An instance of a user name inserted to a balance using capital letters takes below form:

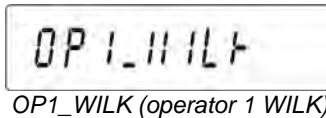

An instance of a user name inserted to a balance using small letters takes below form:

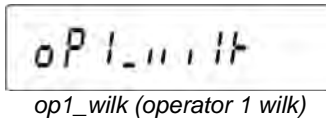

- **P2.2 PrJ**

The parameter enables determining name of a project (e.g. related to a specific type of weighing process).

An instance of project name inserted to a balance using capital letters takes below form:



An instance of project name inserted to a balance using small letters takes below form:

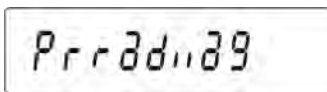

pr radwag

- **P2.3 Ptin**

Option determining presence of measurement time on a printout.

- **P2.4 PdAt**

Option determining presence of measurement date on a printout.

- **P2.5 PUSr**

Option determining presence of user name on a printout.

- **P2.6 PPrJ**

Option determining presence of project name on a printout.

- **P2.7 PId**

Option determining presence of balance factory number on a printout.

- **P2.8 PFr**

Option enabling printing frames on a printout.

For above parameters please select one of two available settings:

no – variable absent on a printout

YES – variable present on a printout

Return to weighing mode with procedure of saving changes

(see point – 8.2. – return to weighing).

14. BALANCE WORKING MODES

- Weighing mode – **bASic**
- Parts counting – **PcS**
- Checkweighing – **HiLo**
- Percent setup with reference mass determined by weighing – **PrcA**
- Percent setup with reference mass determined by a user – **PrcB**
- Density determination of solids – **d_Co**
- Density determination of liquid – **d_Li**
- Pipette calibration – **PIPET.**
- Working mode FiLL - **FiLL**

Press **MODE** key,

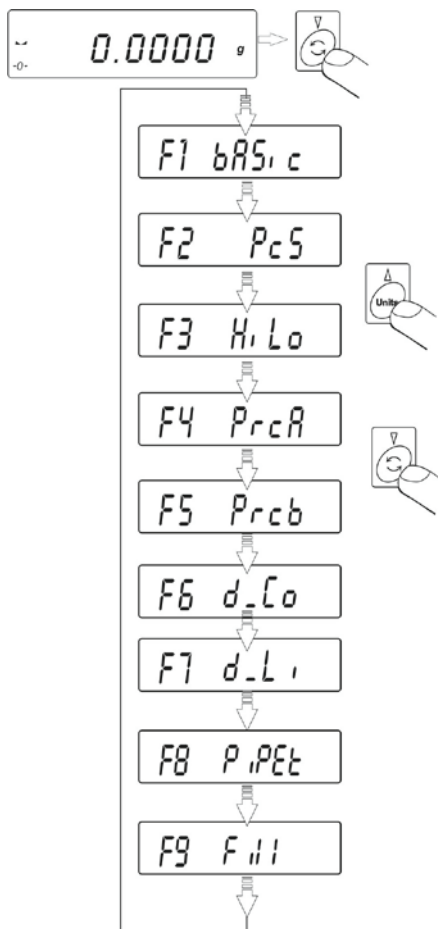

Pressing **MODE** key causes displaying the first available mode. Each next pressing of **UNITS** or **MODE** keys causes displaying name of next available mode. The means of setting a working mode is described in further section of this manual.

14.1. Parts counting of the same mass

Balance in its standard version is equipped with an option for counting parts and small objects of the same unit mass. Parts counting mode does not cooperate with other working modes.

- Enable **PcS** mode,

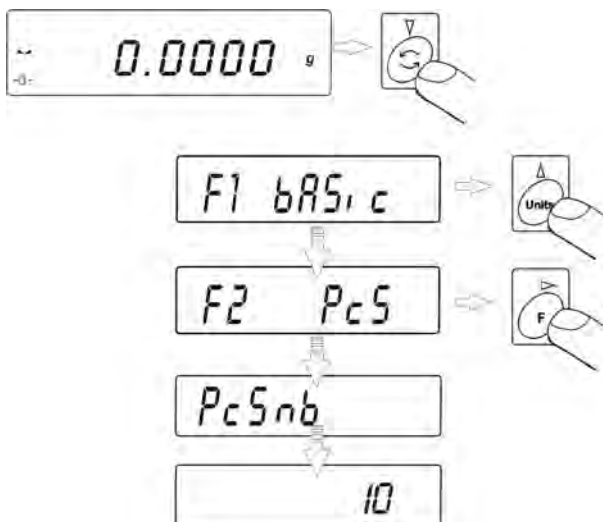

- Press **UNITS** key to set sample quantity **10**, **20**, **50** or **FrEE**,

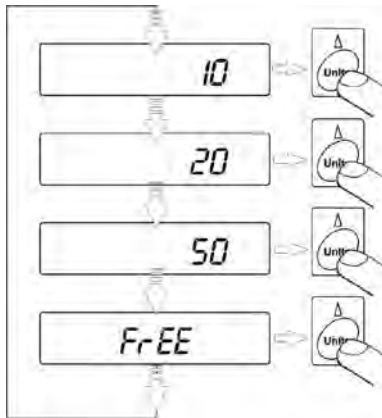

- in order to select one of the options, e.g. 20 pcs press **PRINT** key and proceed as shown on below figure,

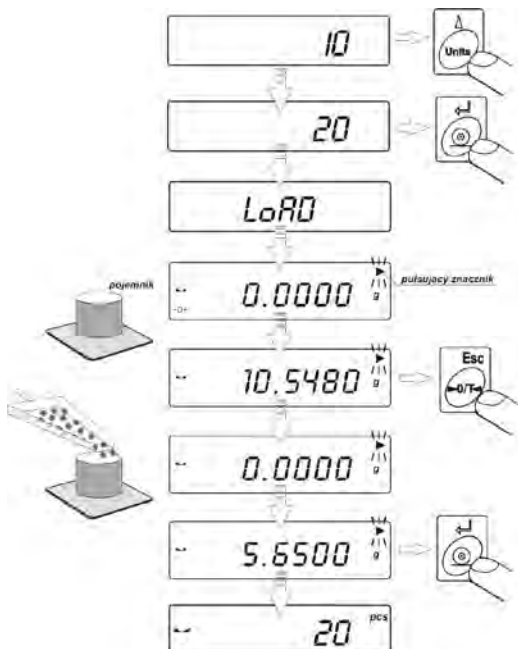

- If option **FrEE** (sample quantity is declared by a user) is selected, insert sample quantity used for determining mass of single part,

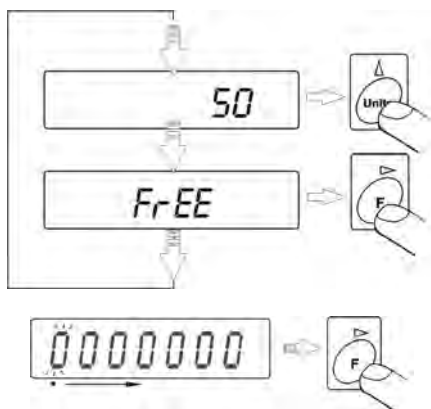

- Press **F** key to select a digit to be altered, and press **UNITS** key to change digit value,

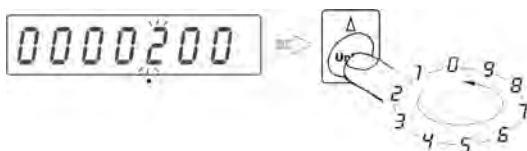

- Accept inserted value by pressing **PRINT** key,
- Display indicates a command **LoAd** – load the weighing pan with as many details as inserted while determining sample quantity,

LoAd

- Press **PRINT** key – balance indicates sample's quantity (**pcs** pictogram is visible on the display),

200 pcs

- add remaining parts, the display indicates their total quantity.

Return to weighing

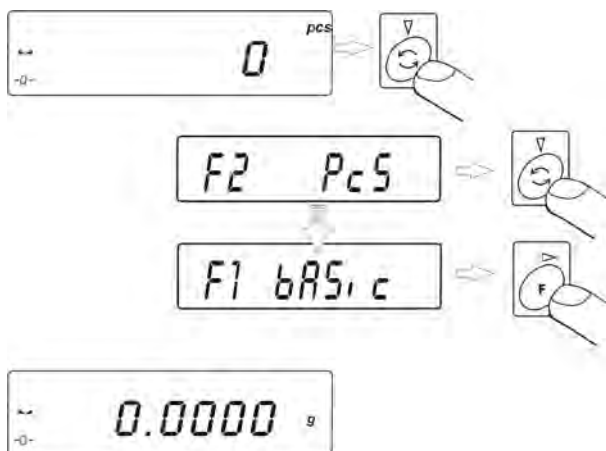

CAUTION:

While determining sample quantity, and before accepting it, it is necessary to wait until stable measurement pictogram  is displayed. Only if visible on balance's display, it is allowed to accept the declared quantity of parts by pressing **PRINT** key. Otherwise balance will not accept the measurement.

14.2. Checkweighing (HiLo) with reference to set standard

- Enter the checkweighing mode,

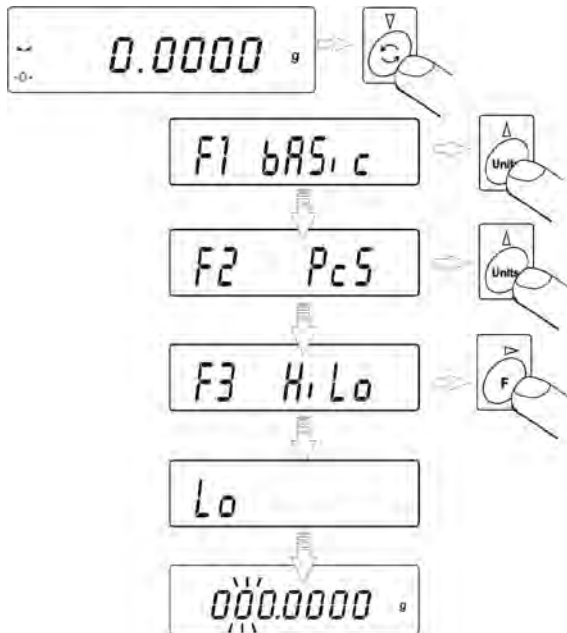

During setting limit values the following relations occur:

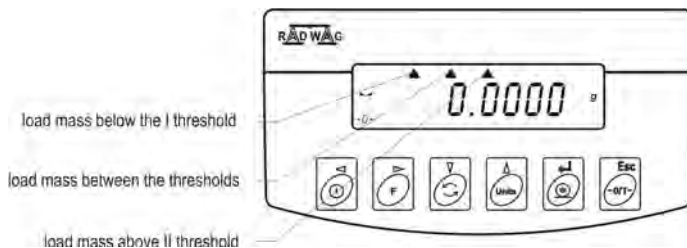

SET LOW LIMIT (LOW THRESHOLD)

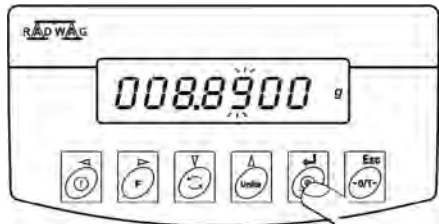
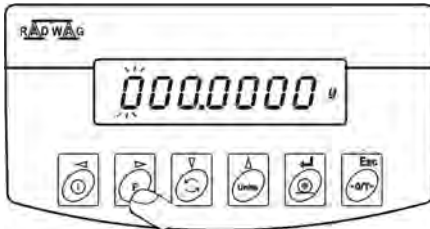
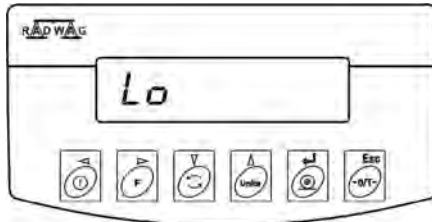

F - digit selection; **UNITS** set digit value; **PRINT** - accept inserted digit value

SET HIGH LIMIT (HIGH THRESHOLD)

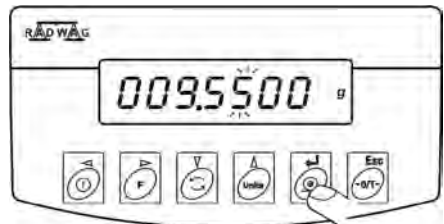
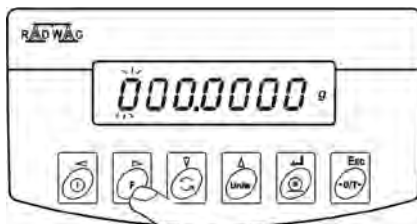
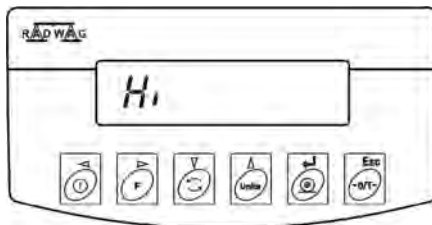

F - digit selection; **UNITS** - set digit value; **PRINT** - accept inserted digit value

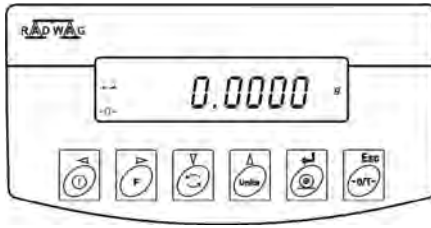

CAUTION:

If by mistake the value of low threshold is set higher than high threshold, balance will indicate error message and return to weighing.

Return to weighing:

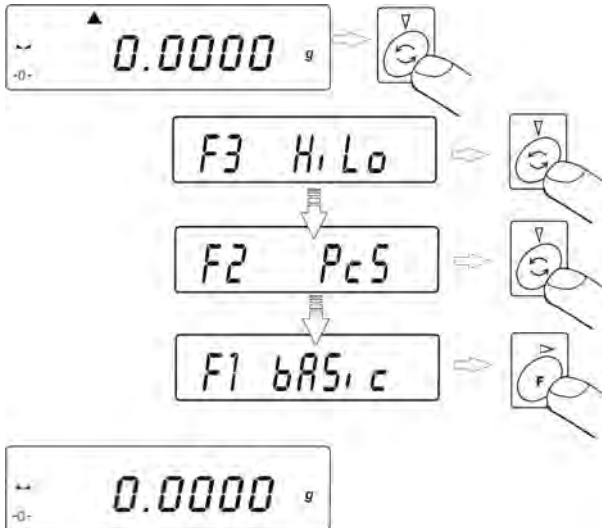

14.3. Percent setup

Balance software enables controlling deviation (in %) of weighed loads with determined reference mass. Mass of a reference load can be determined by its weighing (**PercA**) or entered to balance memory by a user (**PercB**).

14.3.1. Reference mass determined by weighing

- Enter **PrcA** mode:

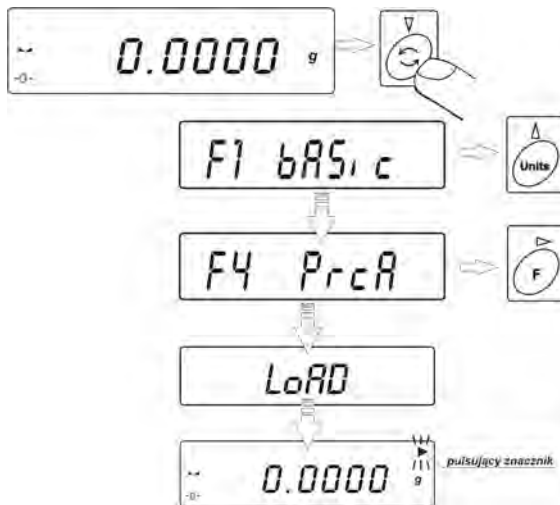

- on balance weighing pan place a load which mass will be accepted as the reference,
- press **PRINT** to accept this working mode,

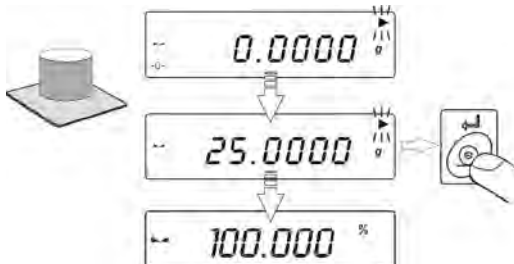

- after few seconds indication **100,00%** will be displayed.

From now on the display will not indicate mass of weighed load but deviation of mass placed on the pan in relation to the reference (in %).

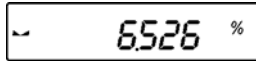

14.3.2. Reference mass set in balance memory by a user

- Enter **PrcB** mode:

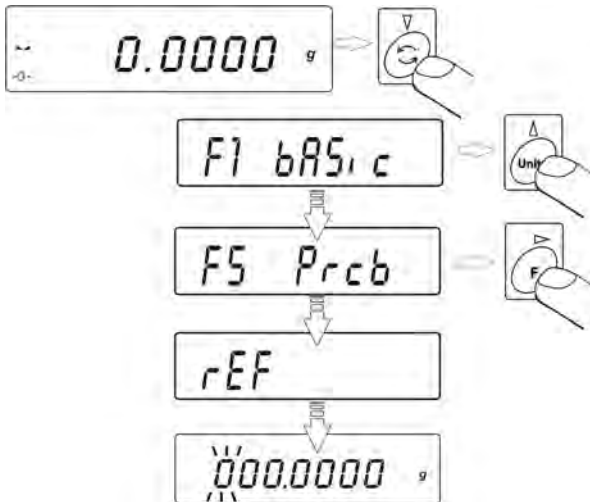

- Display will indicate as above,
- Using function keys:

F – Select a digit



Units – choose digit value

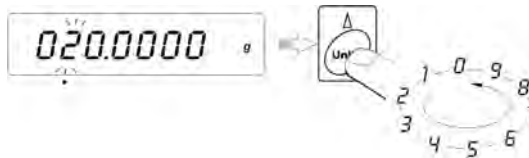

- Determine the **value of reference mass**, insert it to balance memory and accept it by pressing **PRINT** key – display will indicate: **0,00%**

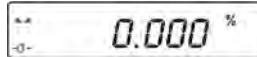

From now on the display will not indicate mass of weighed load but deviation of mass placed on the pan in relation to the reference (in %).

Return to weighing

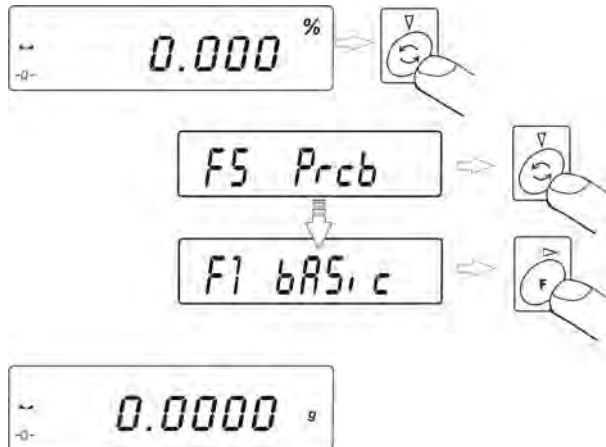

14.4. Working mode FILL

Working mode FiLL enables two settings:

FiLL = NO – mode disabled, i.e. not available in the working modes.

FiLL = YES – mode enabled, i.e. available in the working modes.

If FiLL is enabled, then the balance operates with settings, that are stored in balance's settings as default and ensuring quicker operation. The settings automatically decrease Autozero range to 1 reading interval. Mode activation is signaled by a black triangle pictogram visible on display's right hand side (and above the measuring unit). Working mode FiLL is set to YES as default, thus it is accessible in the working modes. The mode can be disabled from the working modes by setting it to NO. To disable FiLL mode enter menu of available modes – see point 9.3.2 of this user manual.

Enabling FiLL mode in the working modes

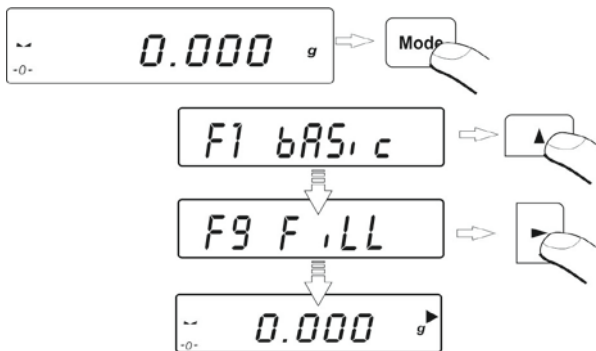

The balance operates in accordance with the settings of AUE and CONF options. The options enable setting shorter or longer measurement time.

Disabling FiLL mode

- | | |
|---------------------------------|--|
| 4. Beaker. | 11. Bottom weighing pan. |
| 5. Thermometer handle. | 12. Supplementary weights |
| 6. Thermometer. | 13. Additional stand for set of pans or a sinker |
| 7. Sinker's flexible connector. | 14. Additional set of pans for determining density of solids, which density is lower than density of water |

14.5.1. Density determination of solids

Density determination of solids can be carried out in two pre-defined types of liquids or user-defined liquid with specified density:

- **H2O** (distilled water),
- **C2H5OH** (spirit 100% +/- 0.1% in temp. 20°C),
- **AnotHEr** (another liquid with specified density)

In case of determining density in water or alcohol it is necessary to specify their temperature. For another liquid, its value (density) is inserted from balance keyboard. Density determination is carried out by weighing a sample first in the air (top weighing pan (9) of the density kit), and then weighing the same sample in liquid (on the bottom weighing pan (11) of the density kit). As the sample is weighed in liquid, the result of density determination is automatically indicated on balance display.

14.5.2. Density determination of liquid

Basic element for determining density of liquids is a glass sinker (3). Its volume is precisely determined and given on sinker's hanger. Before starting liquid density determination, insert the value of sinker's volume to balance memory. In order to measure the density of liquid, first determine mass of the sinker in the air. Then measure mass of the same sinker in tested liquid. The result of liquid density determination is automatically indicated on balance display.

14.6. Pipettes calibration

Structure of pipettes calibration mode is very clear and intuitive. Basically, it requires inserting data on ambient conditions, parameter of calibration process and parameters of a tested pipette.

14.6.1. Data input

In order to start pipettes calibration mode and input required parameters for calibration process, follow the instruction from below figures:

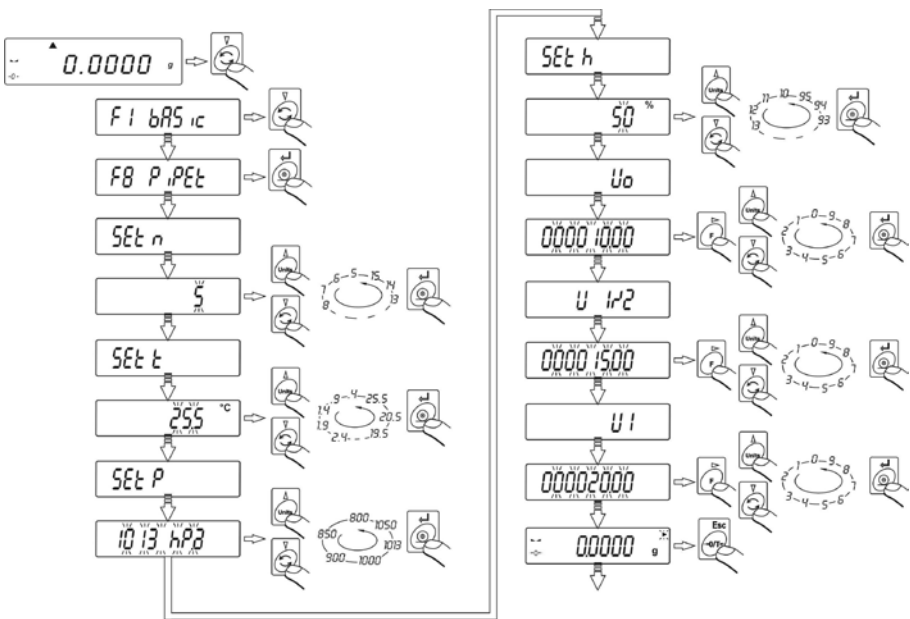

- **Set n** – set quantity of repetitions performed during pipettes calibration (5 ÷ 15),
- **Set t** – set temperature in which pipettes calibration is conducted (0,4 ÷ 25,5 °C),
- **Set P** – set pressure of a weighing room in which pipettes calibration is conducted (800 ÷ 1050 hPa),

- **Set h** – set humidity of a weighing room in which pipettes calibration is conducted ($10 \div 95 \%$),
- **V₀** – initial volume of a pipette (inserted by laboratory assistant),
- **V_{1/2}** – 50% of pipette volume (inserted by laboratory assistant),
- **V₁** – nominal volume of a pipette (inserted by laboratory assistant).

14.6.2. First measuring series

Insert data required for pipettes calibration process and press **ESC/TARE** key (when balance displays stability pictogram) – balance will start the first series of measurements **P1 V₀**. Quantity of repetitions is conditioned by previously declared value of **Set n** parameter.

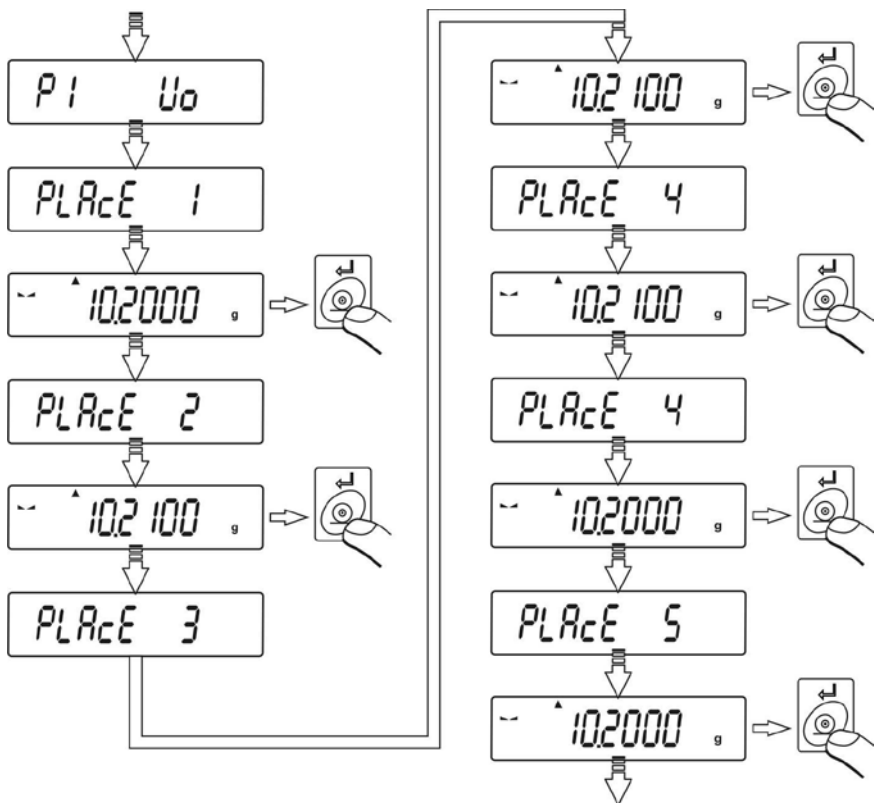

14.6.3. Second measuring series

The second series of measurements is a continuation of first one and procedure is conducted as in case of the first one:

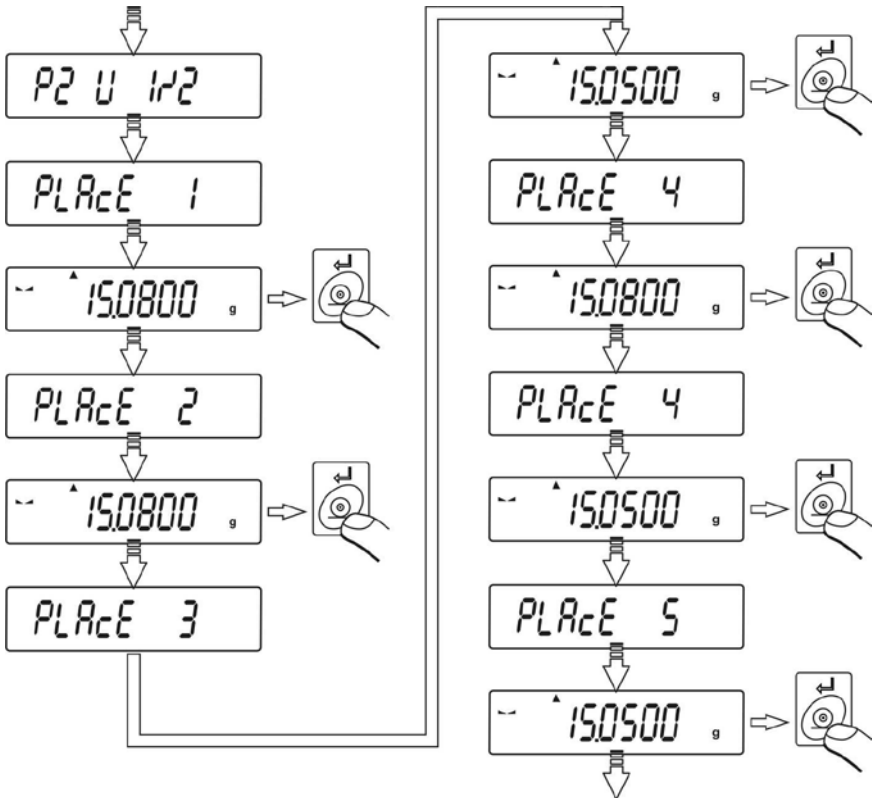

14.6.4. Third measuring series

Third series of measurements is continuation of the second series (procedure does not change). As the third series is completed, balance will display a message on completion of calibration process (**test End**). Using RS 232 output balance will send a report from pipettes calibration to a printer or computer connected to the output. In order to finish the process of pipettes calibration, press **ESC/TARE** key.

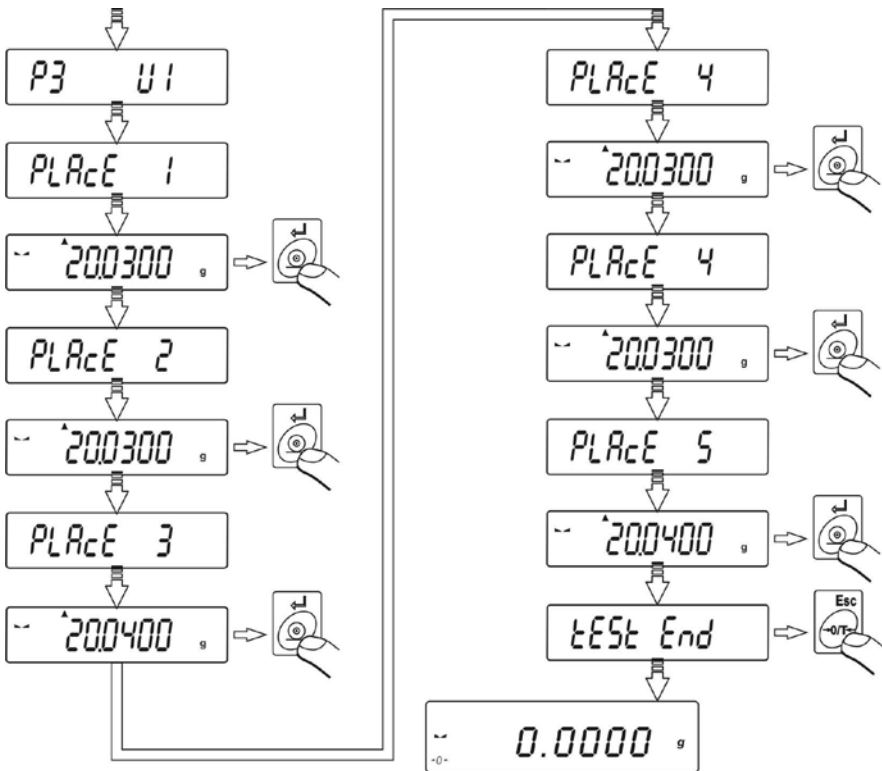

An example of a printout from pipettes calibration:

<input type="checkbox"/>	Temp. :	25.0	C	<input type="checkbox"/>
<input type="checkbox"/>	Pressure :	1013	hPa	<input type="checkbox"/>
<input type="checkbox"/>	Humidity :	50	%	<input type="checkbox"/>
<input type="checkbox"/>	Results Vmin:			<input type="checkbox"/>
<input type="checkbox"/>	1 -	50.24	ul	<input type="checkbox"/>
<input type="checkbox"/>	2 -	50.22	ul	<input type="checkbox"/>
<input type="checkbox"/>	3 -	50.22	ul	<input type="checkbox"/>
<input type="checkbox"/>	4 -	50.22	ul	<input type="checkbox"/>
<input type="checkbox"/>	5 -	50.23	ul	<input type="checkbox"/>
<input type="checkbox"/>	Vmin=	50.00	ul	<input type="checkbox"/>
<input type="checkbox"/>	Results V1/2:			<input type="checkbox"/>
<input type="checkbox"/>	1 -	100.45	ul	<input type="checkbox"/>
<input type="checkbox"/>	2 -	100.44	ul	<input type="checkbox"/>
<input type="checkbox"/>	3 -	100.46	ul	<input type="checkbox"/>
<input type="checkbox"/>	4 -	100.44	ul	<input type="checkbox"/>
<input type="checkbox"/>	5 -	100.44	ul	<input type="checkbox"/>
<input type="checkbox"/>	V1/2=	100.00	ul	<input type="checkbox"/>
<input type="checkbox"/>	Results Vmax:			<input type="checkbox"/>
<input type="checkbox"/>	1 -	150.65	ul	<input type="checkbox"/>
<input type="checkbox"/>	2 -	150.66	ul	<input type="checkbox"/>
<input type="checkbox"/>	3 -	150.66	ul	<input type="checkbox"/>
<input type="checkbox"/>	4 -	150.66	ul	<input type="checkbox"/>
<input type="checkbox"/>	5 -	150.66	ul	<input type="checkbox"/>
<input type="checkbox"/>	Vmax=	150.00	ul	<input type="checkbox"/>
<input type="checkbox"/>	Va=	50.22	ul	<input type="checkbox"/>
<input type="checkbox"/>	Es=	0.4	%	<input type="checkbox"/>
<input type="checkbox"/>	Sr=	0.11	ul	<input type="checkbox"/>
<input type="checkbox"/>	Results V1/2:			<input type="checkbox"/>
<input type="checkbox"/>	1 -	100.45	ul	<input type="checkbox"/>
<input type="checkbox"/>	2 -	100.44	ul	<input type="checkbox"/>
<input type="checkbox"/>	3 -	100.46	ul	<input type="checkbox"/>
<input type="checkbox"/>	4 -	100.44	ul	<input type="checkbox"/>
<input type="checkbox"/>	5 -	100.44	ul	<input type="checkbox"/>
<input type="checkbox"/>	V1/2=	100.00	ul	<input type="checkbox"/>
<input type="checkbox"/>	Results Vmax:			<input type="checkbox"/>
<input type="checkbox"/>	1 -	150.65	ul	<input type="checkbox"/>
<input type="checkbox"/>	2 -	150.66	ul	<input type="checkbox"/>
<input type="checkbox"/>	3 -	150.66	ul	<input type="checkbox"/>
<input type="checkbox"/>	4 -	150.66	ul	<input type="checkbox"/>
<input type="checkbox"/>	5 -	150.66	ul	<input type="checkbox"/>
<input type="checkbox"/>	Vmax=	150.00	ul	<input type="checkbox"/>
<input type="checkbox"/>	Va=	150.65	ul	<input type="checkbox"/>
<input type="checkbox"/>	Es=	0.4	%	<input type="checkbox"/>
<input type="checkbox"/>	Sr=	0.33	ul	<input type="checkbox"/>
<input type="checkbox"/>				<input type="checkbox"/>

- V_{min} , $V_{1/2}$, V_{max} – respectively: initial volume, 50% of pipette volume and nominal pipette volume,
- V_a – arithmetic mean from measurement series,
- E_s – value of systematic error,
- S_r – value of repeatability standard deviation.

15. RS 232 FUNCTIONS

P4 Print

P4.1	bAud		4800
P4.2	CntA		YES
P4.3	CntB		YES
P4.4	rEPI		YES
P4.5	PStb		YES
P4.6	Lo		0.005

P4.1 **bAud** - baud rate setting (speed of transmission)

P4.2 **CntA** - continuous data transmission in basic measuring unit

P4.3 **CntB** - continuous data transmission in current measuring unit

P4.4 **rEPI** - setting operation mode for RS 232 output (manual / automatic)

P4.5 **PStb** - stable / unstable measurement for RS 232 transmission

P4.6 **Lo** - minimal mass required for activation of automatic printout

15.1. Baud rate

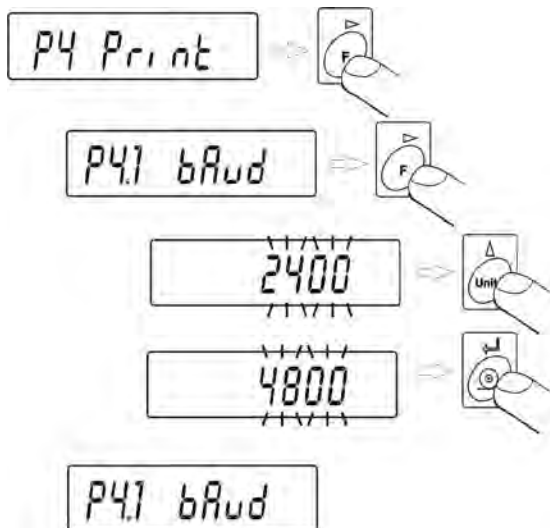

Select required baud rate value

- 2400 bit/s
- 4800 bit/s
- 9600 bit/s
- 19200 bit/s.

Return to weighing mode with procedure of saving changes

(see point – 8.2. – return to weighing).

15.2. Continuous transmission

15.2.1. Continuous transmission in basic measuring unit

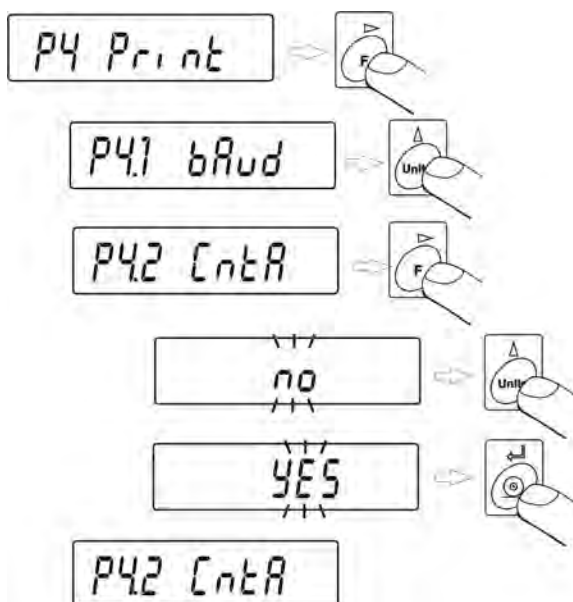

no – continuous transmission disabled

YES – continuous transmission enabled.

Return to weighing mode with procedure of saving changes

(see point – 8.2. – return to weighing).

15.2.2. Continuous transmission in current measuring unit

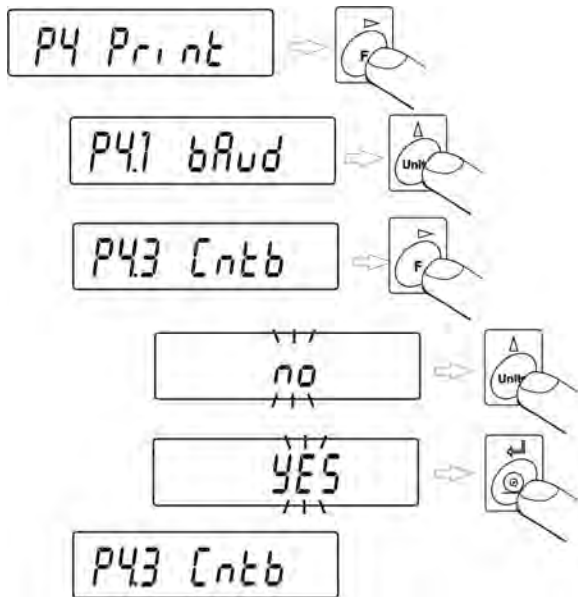

- no** – continuous transmission disabled
- YES** – continuous transmission enabled.

Return to weighing mode with procedure of saving changes
(see point – 8.2. – return to weighing).

15.3. Setting operation mode for RS 232 interface

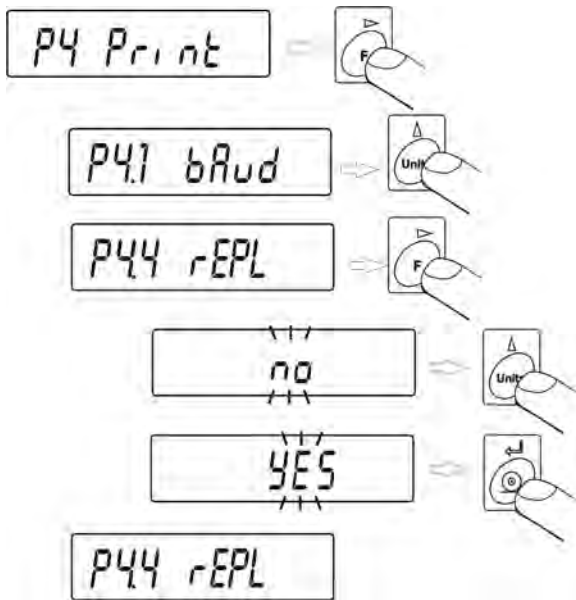

- no** – manual operation (enabled on pressing **PRINT** key)
YES – automatic operation (enabled on stabilization of weighing result).

Return to weighing mode with procedure of saving changes
(see point – 8.2. – return to weighing).

Automatic operation takes place according to the following scheme:

- press **Esc/TARE** key to zero the balance (display will indicate pictograms of stable measurement $\blacktriangle \blacktriangleleft$ and precise zero $\rightarrow 0 \leftarrow$)
- place the load, balance will send first stable measurement through the RS232 interface
- remove the weighed load from the weighing pan,
- next measurement can be conducted if a weighing result equals ± 50 reading units from zero (it is not necessary to reach precise zero to start another measurement).

15.4. Determination of data type sent via RS 232 output

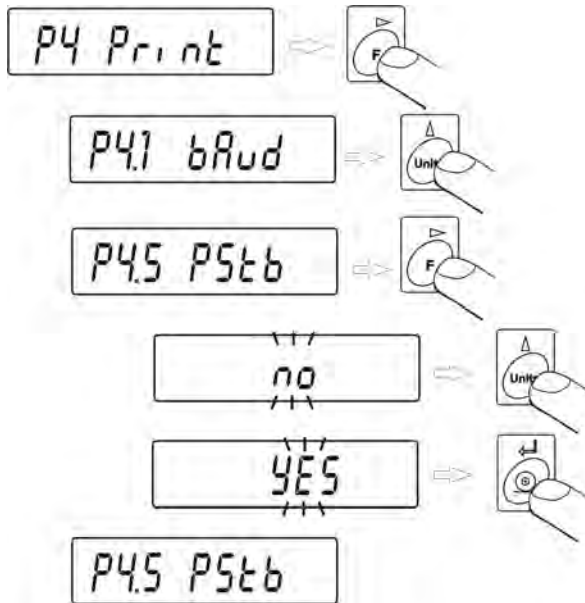

- no** – sending stable or temporary (unstable) weighing result
- YES** – sending stable weighing result.

Return to weighing mode with procedure of saving changes
(see point – 8.2. – return to weighing).

15.5. Minimum mass required for activating automatic printout

Balance software is equipped with a function for setting **automatic operation**. While in automatic operation, data will not be transmitted through RS 232 to a connected computer or printer until mass reading is above **Lo** value.

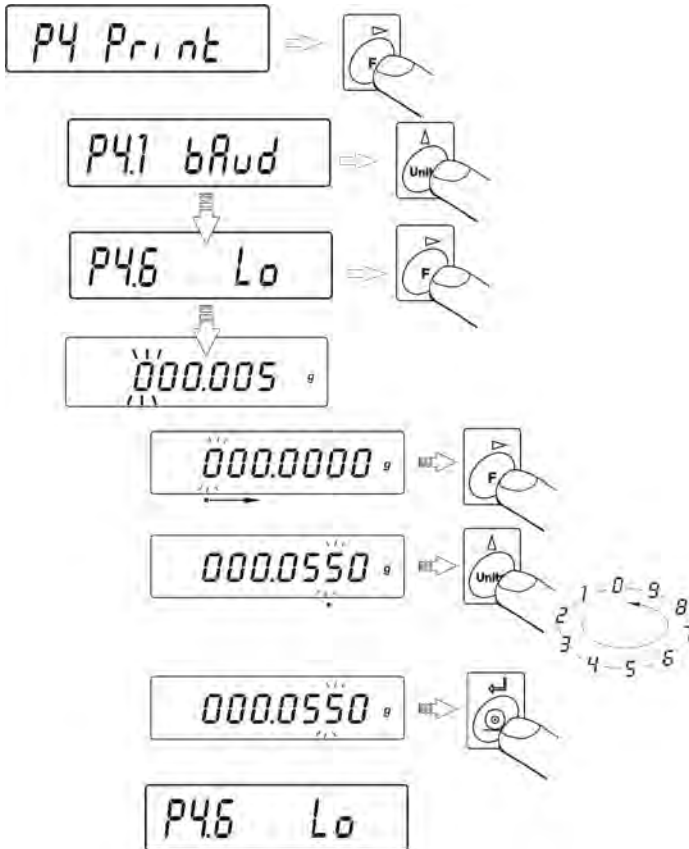

- Press **F** key to select a digit which should be changed, and press **UNITS** key to change value of selected digit.

Return to weighing mode with procedure of saving changes

(see point - 8.2. - return to weighing).

16. COOPERATION WITH A PRINTER OR A COMPUTER

CAUTION



A peripheral device that is connected to RS 3232 output of a balance, has to be powered from the common low voltage power network equipped with common anti-shock protection in a way to preclude possible occurrence of different potentials in zero cables of the peripheral device and the balance.

Transmission parameters programmed in a balance:

- Baud rate - 2400 – 19200 bit / s
- Data bits - 8
- Stop bit - 1
- Parity control - none.

The value indicated on balance display can be sent through RS 232 output to a peripheral device in one of four accessible ways:

- manually - on pressing **PRINT** key
- automatically - on stabilization of weighing result
- continuously - on activation of a function or sending a command
- on command sent from a peripheral device (see additional functions).

Value indicated on balance's display can be sent through RS232 output in the following form:

- stable - data is sent immediately on stabilization of weighing result
- unstable - on pressing of **PRINT** key causes immediate sending of display status to a peripheral device (on a printout such status is marked with <?> symbol proceeding the weighing result).

16.1. Cross-section through connecting conductors

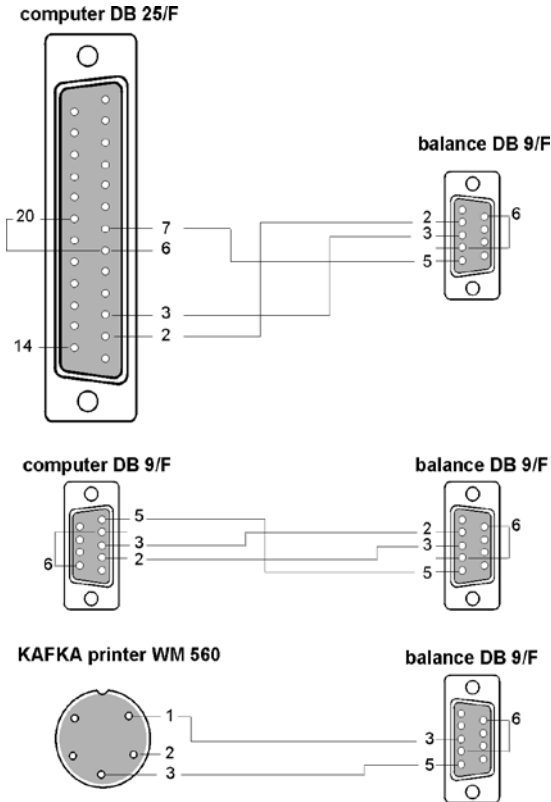

BALANCE

2 (RxD)
 3 (TxD)
 4 (DTR)
 5 (GND)
 6 (DSR)
 7 (RTS)
 8 (CTS)

COMPUTER

3 (TxD)
 2 (RxD)
 6 (DSR)
 5 (GND)
 6 (DTR)
 8 (CTS)
 7 (RTS)

16.2. Printing date with specified date and time

Every weighing result can be printed with specification of measurement date and time. The presence of date and time on a printout is conditioned by connection of printers type **Kafka 1/Z** or **Kafka SQ S** to a balance.

When connected, go to balance menu and set parameters from group **P2 GLP**:

PdAt - YES
Ptin - YES

16.3. Cooperation with statistic printer KAFKA SQS

On connecting a statistic printer **KAFKA SQ S** to a balance, it is possible to carry out statistics from completed measurements. An instance of a printout including statistics from series of measurement:

1	9:02:15	+	7.0016	g
2	9:02:39	+	5.0152	g
3	9:02:58	+	12.0171	g
4	9:03:15	+	9.9937	g
5	9:03:34	+	12.0169	g
6	9:03:48	+	22.0111	g

Date 13.09.2001 Time 9:04

<i>n</i>	6		<i>batch quantity</i>
<i>sum x</i>	68.0556	g	<i>total mass of samples</i>
\bar{x}	11.34260	g	<i>average value</i>
<i>s</i>	5.92328	g	<i>standard deviation</i>
<i>srel</i>	52.22	%	<i>variance factor</i>
<i>min</i>	5.0152	g	<i>min value</i>
<i>max</i>	22.0111	g	<i>max value</i>
<i>R</i>	16.9959	g	<i>difference max – min</i>

16.4. Format of data sending

Weighing result can be sent to a peripheral device by pressing **PRINT** key on a balance keyboard or by setting a control command from computer level.

16.4.1. Format of data sent on pressing of PRINT key

Depending on setting of **P4.5 PStb** parameter only stable measurement or instantaneous mass indication will be sent.



CAUTION:

For verified balances printout of instantaneous measurement data is blocked.

Printout format

1	2	3	4 - 12	13	14 - 16	17	18
stability marker	space	sign	mass	space	unit	CR	LF

- stability marker – [space] if stable
- [?] if unstable
- [^] if there is an error of range exceeding on +
- [v] if there is an error of range exceeding on -
- sign – [space] for positive values or [-] for negative values
- mass – 9 marks alignment to the right
- unit – 3 marks alignment to the left

16.4.2. Format of data sending as response to commands generated from a computer

On receipt of a command, balance responses with:

- XX_A CR LF – command understood, in progress
- XX_I CR LF – command understood, but currently not available
- XX_^ CR LF – command understood, but max range is exceeded
- XX_v CR LF – command understood, but min range is exceeded
- XX_E CR LF – error occurred while carrying out the command – time limit exceeded while waiting for stable measurement result (time limit is characteristic parameter of balance)
- XX – name of command

And followed by:

1 - 3	4	5	6	7	8 - 16	17	18 - 20	21	22
Command	space	stability marker	space	sign	mass	space	unit	CR	LF

- Command – 1 ÷ 3 characters
- stability marker – [space] if stable
– [?] if unstable
– [^] if there is an error of range exceeding on +
– [v] if there is an error of range exceeding on -
- sign – [space] for positive values or [-] for negative values
- mass – 9 marks alignment to the right
- unit – 3 marks alignment to the left

17. UNDER HOOK WEIGHING

In standard analytical and precision balances loads can be weighed under the weighing pan. Such means of operation requires placing a balance on a uplifted position. RADWAG offers a rack for under hook weighing. The rack is an optional equipment offered for balances AS series.

For under hook weighing follow below procedure:

- Remove plastic hole plug in basis of a balance;
- There is suspension place for hook visible in the hole – the suspension is installed permanently to balance mechanism;
- In the hole install the hook for under hook weighing - the hook is standard equipment of a balance. Weigh loads using under hook option;
- As under hook weighing is finished, close the hole in balance basis with plastic hole plug.

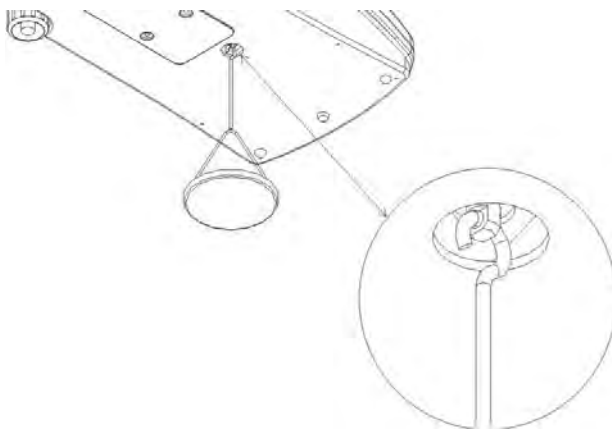

CAUTION:

The suspension for hook must not be turned, twisted or manipulated in any direction. Such actions may cause damage to balance mechanism.



Mass of all additional elements of under hook weighing kit, like: the hook, weighing pan, string, etc. should be zeroed by pressing **Esc/TARE** key.

18. LIST OF COMMANDS: COMPUTER – BALANCE

• Function Command	TARE T CR LF (balance tarring)
• Function Command	ZERO Z CR LF (balance zeroing)
• Function Command	IMMEDIATELY SEND WEIGHING RESULT IN BASIC MEASURING UNIT SI CR LF (immediately send of balance indication)
• Function Command	SEND WEIGHING RESULT IN BASIC MEASURING UNIT S CR LF (send result when stable)
• Function Command	SEND WEIGHING RESULT IN CURRENT MEASURING UNIT SU CR LF (send result with current unit when stable)
• Function Command	IMMEDIATELY SEND WEIGHING RESULT IN CURRENT MEASURING UNIT SUI CR LF (send result in current unit now – do not wait for stable reading)
• Function Command	CONTINUOUS TRANSMISSION IN BASIC MEASURING UNIT C1 CR LF (start continuous transmission in basic unit)
• Function Command	END OF CONTINUOUS TRANSMISSION IN BASIC MEASURING UNIT C0 CR LF (finish continuous transmission in basic unit)
• Function Command unit)	CONTINUOUS TRANSMISSION IN CURRENT MEASURING UNIT CU1 CR LF (start continuous transmission in current unit)
• Function Command	END OF CONTINUOUS TRANSMISSION IN BASIC MEASURING UNIT CU0 CR LF (finish continuous transmission in current unit)

**CAUTION**

If a non-existing or incorrect command finished with CR LF will be sent to a balance, it responds with ES CR LF. Space between characters should be omitted, as they are added only for the purpose of proper legibility.

19. ERROR MESSAGES

Er1 Hi – mass out of range on balance start and adjustment

Er2 nuLL – value from AD converter ≤ 0 ($A/D \leq 0$)

Er3 FuL1 – values from A/D converter \geq maximal converter range ($A/D \geq 0$)

Er4 FuL2 – maximal capacity of the balance exceeded (over load)

Er5 rout – mass value out of range (during adjustment, determining reference for sample quantity and percent setup, etc.),

Er7 tout – timeout error for zeroing and tarring

Er8 outr – enter value (from keyboard level) out of range (setting thresholds / limits values)

Er9 Lock – function blocked (e.g. by LFT),

Er10 cal – adjustment error (change of mass or incorrect mass of adjustment weight / mass standard).

20. ADDITIONAL EQUIPMENT

20.1. *Anti-vibration table*



It is a very stable basis which eliminates all kinds of vibrations and ground shakes. The inner part of the table holds a marble plate, which is a foundation for balance positioning.

20.2. *Rack for under hook weighing*

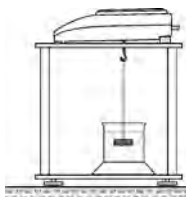

The rack is used if under hook weighing option has to be applied. Under hook weighing is necessary if magnetic loads are weighed or during density determination of substances. Racks are also used for measuring absorptiveness of substances e.g. foamed polystyrene. The rack is made of mild steel. Rack height is 330mm.

20.3. *Density determination kit (for solids and liquids)*

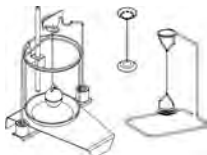

It is applicable with balance with resolution at least 1 mg. Designed for density determination of solids and liquids. The procedure is fully automatic, i.e. the user only places samples on kit's weighing pans.

20.4. *Additional display*



Features: Length of conductor between additional display and balance – 1,5m, plastic casing, possibility of tilting the additional display head.

20.5. Computer software



PW-WIN 2004 - gathering data. Data is gathered in tabular or chart format. It is possible to calculate statistics from a series of weighing records.



RAD-KEY 2000 – implements a set of commands for controlling a balance, e.g. tarring, start of continuous transmission, cyclic commands set to a balance.



REC-FS 2000 - application for control of formulas. It enables creation of a formula, declare tolerance limits for each ingredient and measure mass of each ingredient of a formula.

*Number of instruction:
LMI-16-09/05/12/A*

MANUFACTURER
OF ELECTRONIC WEIGHING INSTRUMENTS



RADWAG WAGI ELEKTRONICZNE

26-600 Radom

28 Bracka

POLAND

phone +48 48 38 48 800

fax. + 48 48 385 00 10

e-mail: export@radwag.com

www.radwag.com



DIN EN ISO 9001:2000
CERTYFIKAT Nr 71 100 C20E