

Turbidity sensor *TurbiMax W CUS 41*

Process and immersion sensor for service water and solids content measurement according to the 90° scattered light method



*CUS 41 with
optional
wiper*

The CUS 41 turbidity sensor can be installed inline without additional sampling systems.

Areas of application

- Sewage treatment plants
 - Primary sludge
 - Activated sludge
 - Returned sludge
 - Digested sludge
- Paper
 - Monitoring sieve water
 - Water processing
- Concrete
 - Measurement of soiling
- Production
- Water monitoring

Benefits at a glance

- Measuring range from 0.01 FNU (NTU) to 300 ppm (g/l)
- Compact shock-proof design
- Measurement according to ISO / EN
- No calibration during operation necessary
- 3-point calibration and 1-point adjustment
- For installations in pipes or basins
- Simple commissioning
- Optional wiper for cleaning, can be retrofitted
- Integrated temperature measurement
- Inclined plane sensor surface uses process flow to increase the self-cleaning effect and repels air bubbles
- Scratch-resistant sapphire glass measuring window
- Permissible distance between sensor and transmitter up to 660 ft (200 m)

Endress + Hauser

The Power of Know How



Function and system design

Measuring principle

Nephelometric measuring principle 90° NIR scattered light according to ISO 7027 / EN 27027

The 90° scattered light method with a wavelength in the near-infrared range (880 nm) according to ISO 7027 / EN 27027 records turbidity values under standardized, comparable conditions. A temperature signal is also recorded and transmitted in addition to the turbidity signal. The excitation radiation of an infrared transmitter (item 1 below) strikes the process fluid at a defined angle of beam. The different refractions of light between the entrance window and the process are taken into account. Particles in the medium (item 5) create a scattered radiation which strikes the scattered light receivers (items 3 and 4) at a defined angle of beam. The measurement in the process is constantly compared with the values of a reference receiver (item 2). Digital filter functions with excellent interference signal suppression and sensor self-monitoring ensure additional measurement reliability.

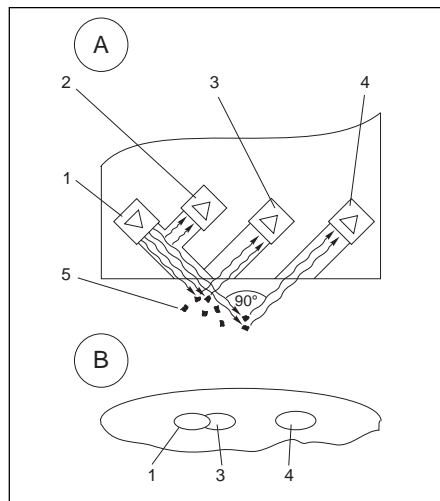

A Side view of the sensor (cutaway)

- 1 Infrared transmitter
- 2 Reference diode
- 3 Scattered light receiver 1
- 4 Scattered light receiver 2
- 5 Particles in the process

B Top view of the sensor surface with optical windows

Turbidity measurement according to ISO 7027 / EN 27027

| | |
|-------------------------------|--|
| Wavelength | 880 nm |
| Radiation compensation | Using reference photodiodes |
| Factory calibration | Traceable to formazine standard and SiO ₂ |

Measuring system

A measuring system consists of:

- CUS 41 sensor mounted in a flow assembly or immersion holder
- A transmitter, e.g. Liquisys M CUM 223 / 253

Options:

- CYH 101 universal suspended holder for immersion operation in basins or channels
- DipFit W CYA 611 immersion holder or FlowFit W CUA 250 flow assembly or ProbFit W CUA 461 retractable holder
- VBM junction box for measuring cable extension
- ChemoClean automatic spray cleaning system

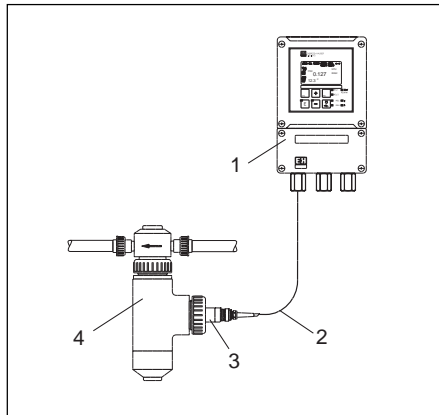

Flow measurement

- 1 Liquisys M CUM 253 transmitter
- 2 Sensor measuring cable
- 3 TurbiMax W CUS 41 sensor
- 4 FlowFit W CUA 250 flow assembly

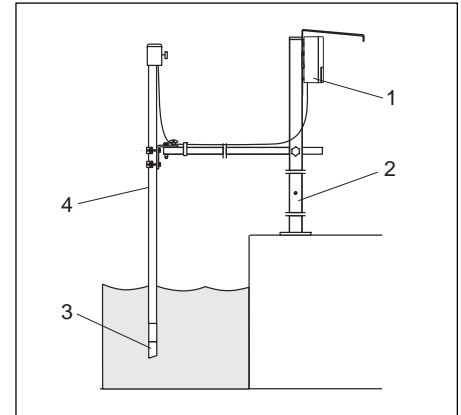

Measuring system with immersion holder

- 1 Liquisys M CUM 253 transmitter
- 2 CYH 101 assembly holder (with CYY 101 weather protection cover)
- 3 TurbiMax W CUS 41 sensor
- 4 DipFit W CYA 611 immersion holder

Input

Measured variable

Turbidity

Measuring range

0.000 to 9999 FNU / 0.00 to 3000 ppm / 0.0 to 300 g/l / 0.0 to 200.0 %

Electrical connection

Cable connection

CUS 41 cable assignment, for sensor and transmitter.

A measuring extension cable (CYK 81), is a 4-wire, shielded fixed cable (2 x 2 twisted pairs) with free cable ends for extending from a VBM junction box to the transmitter.

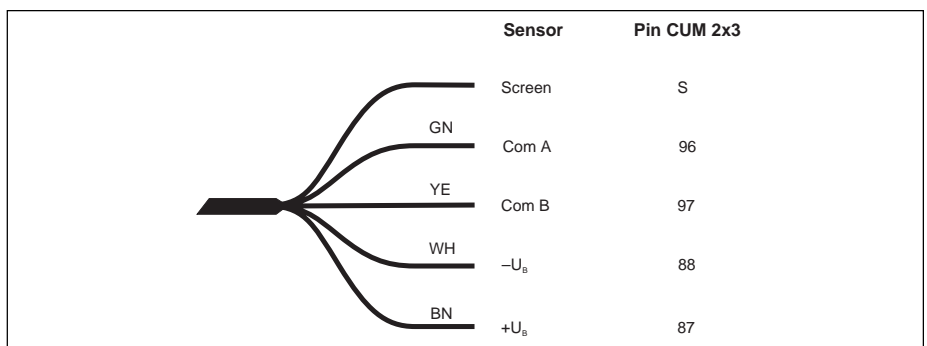

CUS 41 cable assignment for sensor and transmitter

Operating conditions (installation)

Installation instructions

- Each sensor is calibrated in the factory according to standard procedures (ISO 7027 / EN 27027)
- The calibration data is stored in the sensor
- Customer-specific or material-specific calibrations can also be stored
- The calibration values are listed in a quality certificate which is enclosed with each sensor
- Sensor systems with holders are available to meet the requirements of the drinking water sector. The sensor is already installed in the holder and is calibrated with the holder.
- Various holder assemblies are available for the industrial water sector.
- Installing the sensor in piping or very close to a wall can cause backscatter which results in a higher signal.

To compensate for this factor, an installation adjustment may have to be performed by means of the transmitter (refer to Operating Instructions for the CUM 223/253 BA 200C/07/en).

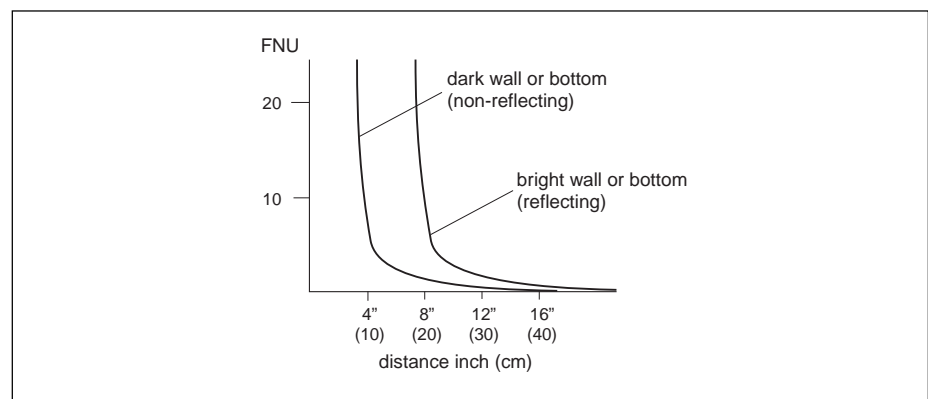

Effect of the distance from wall or bottom

Installation in immersion holders

When installing the CUS 41 in immersion holders, such as the CYA 611 with pendulum frame, please ensure that a sufficient wall distance is observed during operation. The distance between the sensor and a wall should be greater than 4" (15 cm) even with varying levels or altered flow profiles. Mounting in a suspended assembly with chain must therefore be avoided. The sensor must be immersed a minimum of 1.5" (4 cm) into the process.

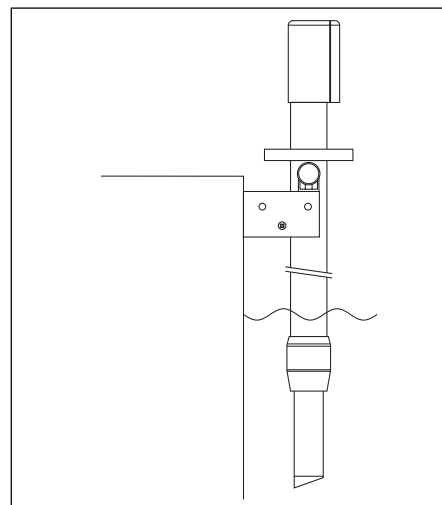

CUS 41 mounted in CYA 611 holder with pendulum frame

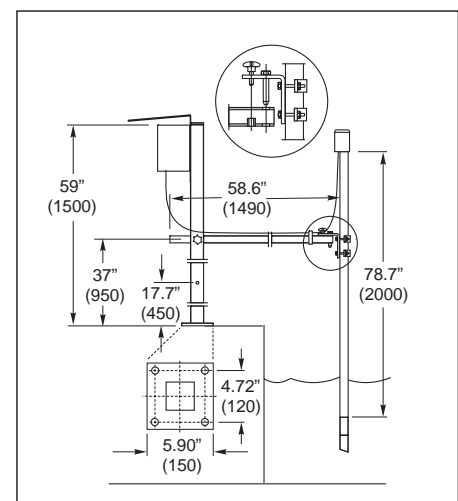

CYH 101 assembly holder with CYA 611 assembly

Pipe installation

The following diagram illustrates various installation positions in piping and indicates whether they are permitted or not.

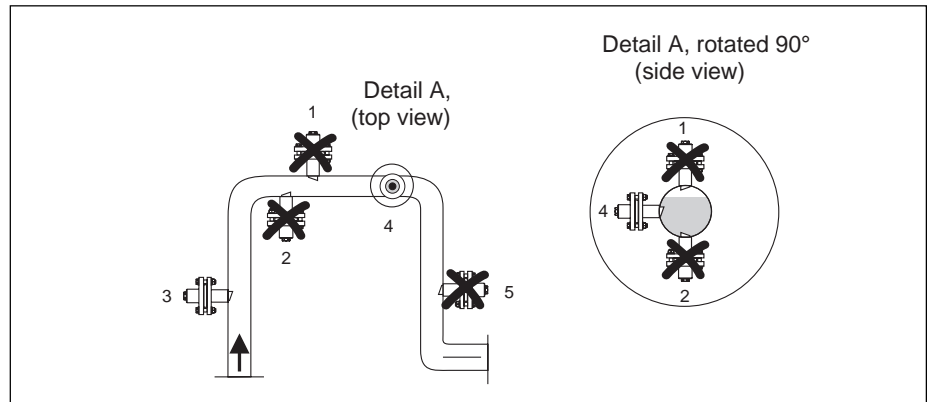

Orientation and installation positions of the CUS 41 with CUA 120-A/B adapter or with CUA 461 retractable holder

- The pipeline diameter must be at least 4" (DN 100) if pipe material is made of reflective materials (e.g. stainless steel).
- Install the sensor in places with uniform flow conditions and not in places where air may collect or foam bubbles form (1) or where suspended particles may settle (2).
- The best installation location is in the ascending pipe (3). Installation is also possible in the horizontal pipe (4), but should be avoided in the down pipe (5).
- Orientate the sensor surface against the process flow ("self-cleaning effect").

Installation in flow assemblies

Install the sensor according to the instructions provided with the FlowFit W CUA 250 flow assembly (TI 096C/24/ae).

- If possible, install the flow assembly vertically so that the process flows upwards past the sensor. The assembly can be installed horizontally. When installed horizontally, the sensor should be in the 3 o'clock or 9 o'clock position to avoid air pockets.
- Two sensor orientations are possible for horizontal installation:
 - parallel to the process flow
 - against the process flow
- Orientation parallel to the process flow is required when using the CUR 3 spray head. This orientation is recommended for turbidities < 5 FNU to minimize wall reflection effects.
- Orientation against the process flow is used to increase the self-cleaning effect in heavily-soiled media (> 15 FNU). The wall reflection is negligible here due to the high absorption tendency.

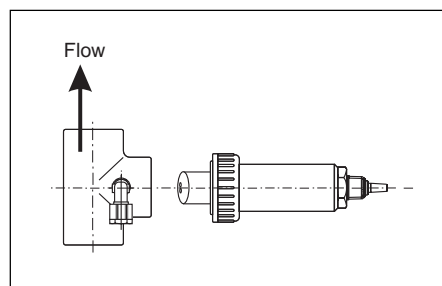

Parallel to sensor orientation

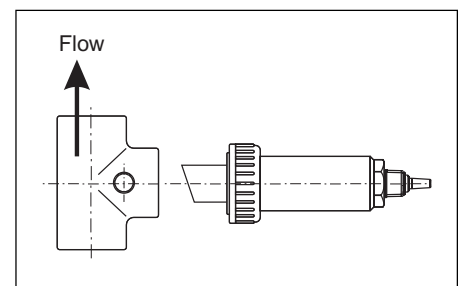

Sensor orientation against process flow

Performance characteristics

Maximum measured error < 5% (minimum 0.02 FNU) of the measured value (system measured error related to the primary formazine standard / tracing according to ISO 5725 and ISO 7027 / EN 27027).

Repeatability < 1% (minimum 0.01 FNU) of the measured value

Operating conditions (environment)

Storage temperature -4° to +140°F (-20 to +60°C)

Ingress protection NEMA 6P (IP 68)

Operating conditions (environment)

Process temperature range 23° to 122°F (-5 to +50°C)

Process pressure range Temperature dependent, 14.5 psi at 122°F (1 bar at 50°C) to 87 psi at 77°F (6 bar at 25°C)

Process connection 3/4" NPT and G 1

Mechanical construction

Dimensions

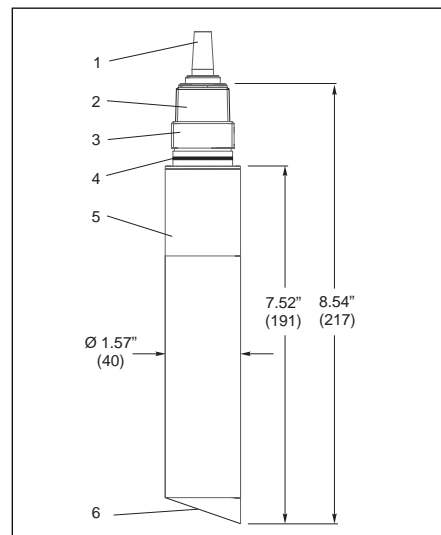

CUS 41 sensor
 1 Fixed cable
 2 3/4" NPT thread
 3 G 1 thread
 4 O-ring
 5 Sensor shaft
 6 Sensor surface with optical windows

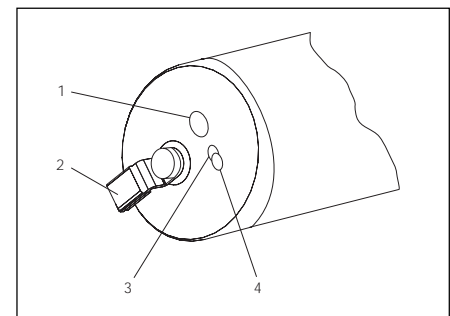

Optical window surface
 1 Photodiode (receiver diode)
 2 Wiper (optional)
 3 Photodiode (receiver diode)
 4 LED (IR transmitter diode)

Wiper cleaning (optional) The CUS 41-W sensor is equipped with a rubber wiper for removing deposits from the sensor carrier plate. The cleaning times and intervals are controlled by the transmitter.

Temperature sensor NTC-resistance 30K at 77°F (25°C)

Materials Sensor carrier plate, shaft: PVC / PPS GF 40 (polyphenylene sulfide with 40% glass fiber)
 Optical windows: Sapphire
 Flow assemblies: PVC

Certificates and approvals

Quality certificate

Each sensor has an individual quality certificate with information on the sensor identification and calibration according to ISL 7027 / EN 27027. The quality certificate is enclosed with each sensor.

Ordering information

TurbiMax W CUS 41

CUS 41 - 1 2

- 1 Sensor
 - A Sensor in standard version
 - W Sensor with integrated wiper
- 2 Cable length
 - 2 Connecting cable, 22 ft. (7 m)
 - 4 Connecting cable, 49 ft. (15 m)
 - 9 Connecting cable according to customer specifications

Accessories

FlowFit W CUA 250 flow assembly

CUA 250 - 1

- 1 Version
 - A Installation in DN 25 - threaded joint
 - B Installation in DN 63 pipe segments (adhesion)
 - Y Special version to customers specifications

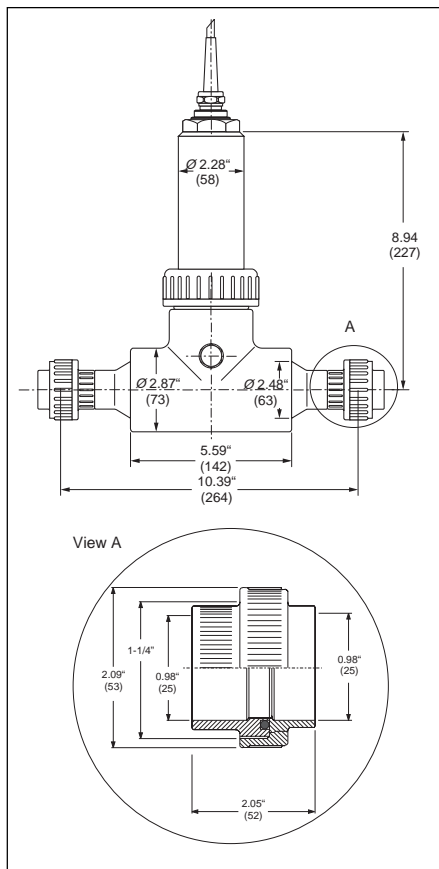

CUA 250 -A / -B

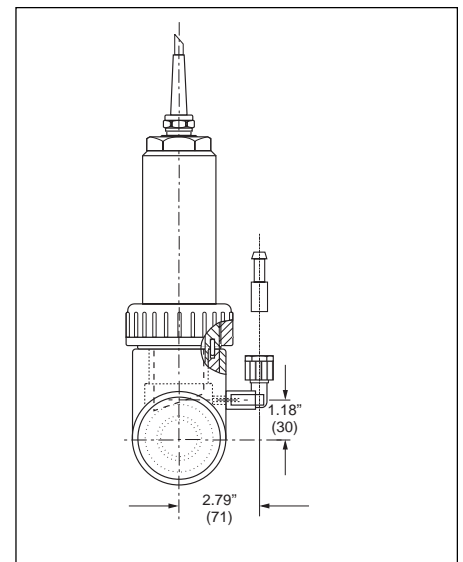

CUA 250 with CUR 31 spray head

ProbFit CUA 461 retractable holder

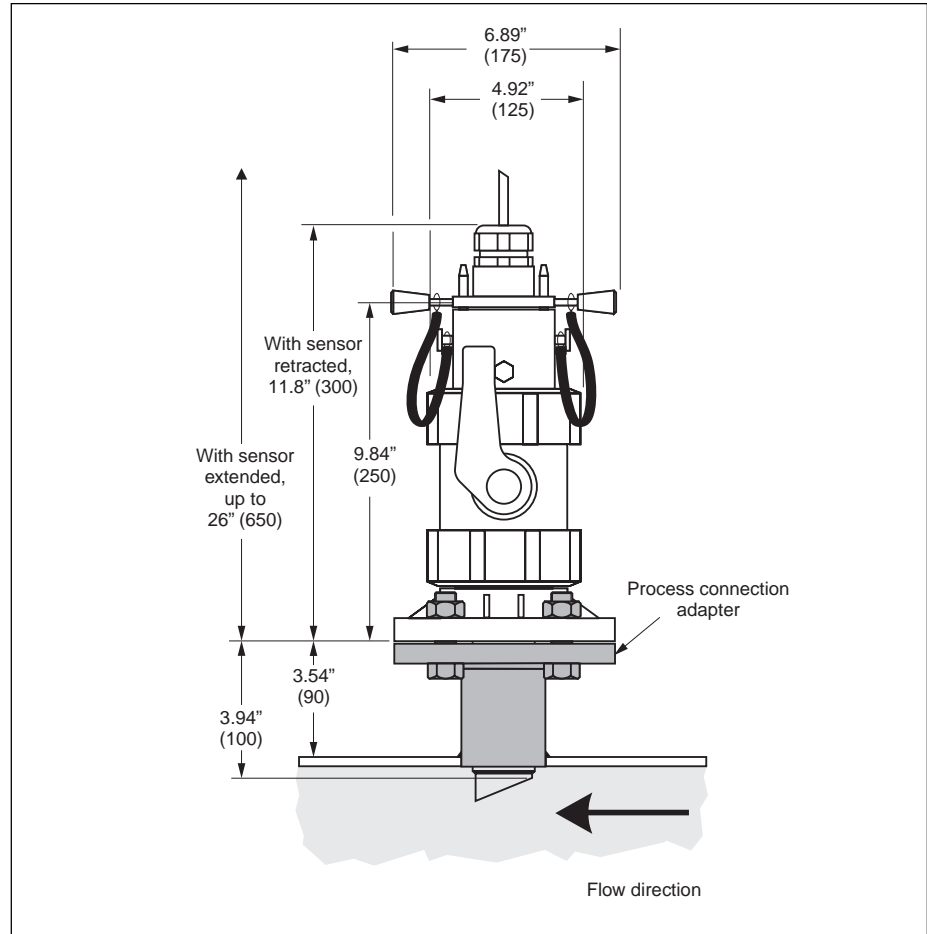

CUA 461 retractable sensor holder assembly

CUA 461 - 1 2

- 1 Version / type of installation
 A Process connection / flange DIN DN 50
 B Process connection / flange, ANSI 2"
- 2 O-ring seals
 1 EPDM material
 2 Viton material

CUA 120 installation holder

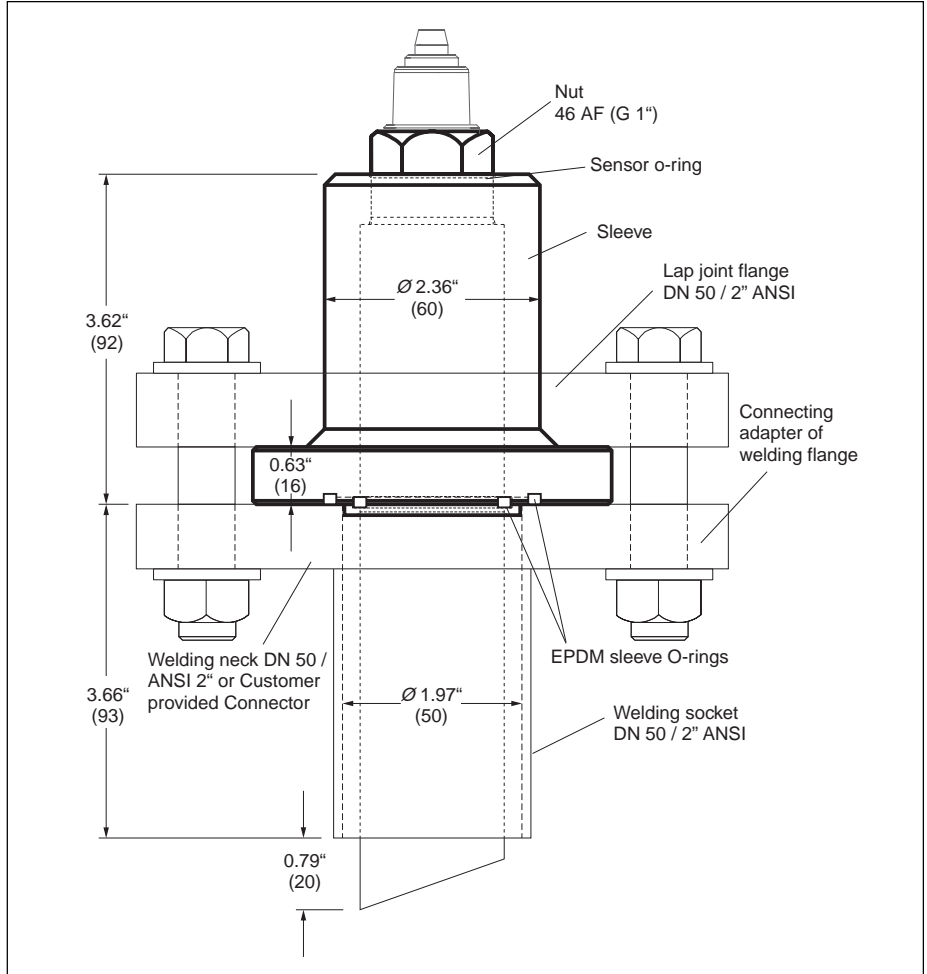

CUA 120-B adapter with welding socket DN 50 / ANSI 2" with lap joint flange

CUA 120 - ¹ □

- 1 Version
- A Adapter for welding neck flange (flange height 1.85" / 47 mm)
- B Adapter for installation socket (socket height 3.66" / 93 mm)
- Y Special version to customer's specifications

Weld neck adapter

Welding neck adapter for adaption to process pipes with diameter greater than 3" (80 mm). Used with CUA 461 or CUA 120 sensor holder.

| Material | Order No. |
|--------------------------|-----------|
| 316Ti SS | 50080249 |
| PVC (polyvinyl chloride) | 50080250 |
| PP (polypropylene) | 50080251 |

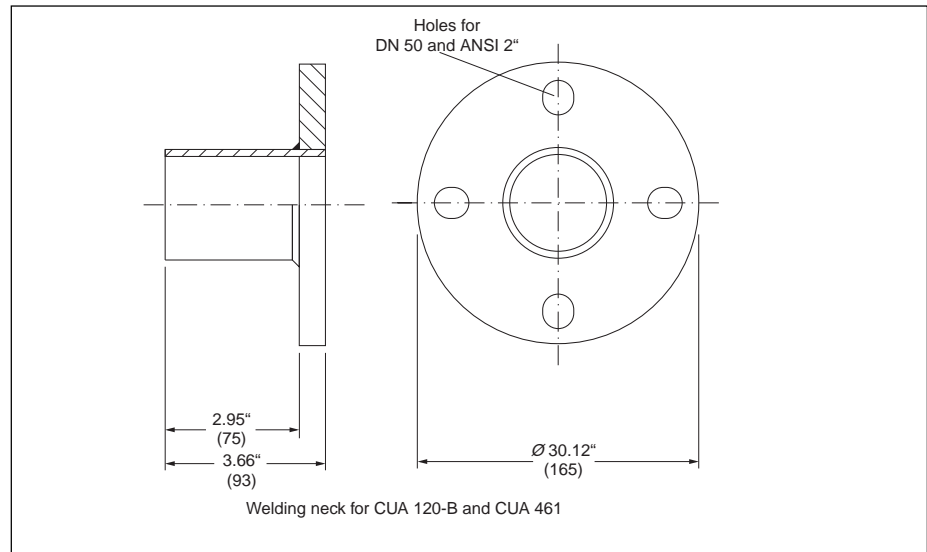

Welding socket for CUA 461 or CUA 120

CUY 22 check unit

Check unit for CUS 31 and CUS 41 for checking the stability of the sensor
Order no. 51504477

CUR 3 spray head

Spray head for cleaning turbidity sensors in flow holders
Order no. CUR 3 - 1

CUR 4 spray head

Spray head for cleaning turbidity sensors in immersion holders
Order no. CUR 4 - A

Recalibration

CUS 41 recalibration according to ISO 7027 / EN 27027
Order no. 50081264

CUY 31 service kit

3 spare wiper arms for CUS 31/CUS 41
Order no. 50089252

CYK 81 measuring cable

Cable for extending CUS 31 / 41 sensors to transmitter from RM junction box, four-core shielded measuring cable (2 x 2 twisted). Minimum length 33 ft (10 m).
Order no. 51502543

RM shunt resistance

For external change of current output to voltage output (0/4 to 20 mA to 0/2 to 10 V)
Order no. 51500836

RM junction box

Junction box between CUS 31 / 41 sensors fixed cable and CYK 81 extension cable, NEMA 4 (IP 65), two 13.5 Pg cable entries.
Order no. 51500832

RM sensor holder

Holder assembly for mounting CUS 31 / 41 at basin rim or grid via angle bracket and immersion tube (galvanized steel). Bracket is stainless steel
Order no. 51500734

Sensor maintenance

Sensor with wiper cleaning option

The CUS 31 / 41 sensors are available with an integrated wiper assembly. Cleaning intervals and times are entered into the Liquisys M CUM 253 / 223 transmitter. For optimum cleaning, wiper time is adjustable. To ensure the wiper assembly is in the rest position, perform the following:

- Pull the sensor from the holder assembly
- Moisten the sensor surface
- Set type of cleaning and cleaning times on the transmitter and start the cleaning cycle
- Check the wiper movement (cycle) on the sensor, the wiper must return to the rest position

Caution!

Do not move the wiper arm by hand!

Note:

If the wiper comes to rest over the measuring windows, then measuring errors will result.

A = Rest position of the wiper arm; tolerance range, $\pm 20^\circ$

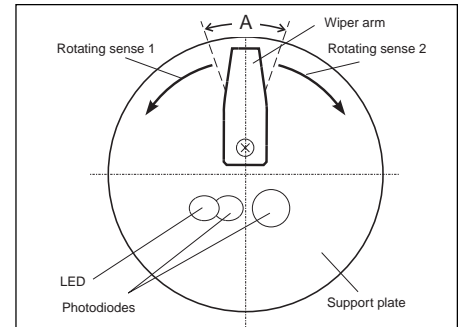

Sensor cleaning

Deposits on the sensor optics may result in inaccurate measurement; therefore, the sensor must be cleaned at regular intervals. The intervals are specific to each installation and must be determined during operation. The following cleaning agents can be used, depending on the type of fluid deposits.

Clean the sensor mechanically, using a soft brush. Then rinse thoroughly with water.

| | |
|--------------------------|---|
| Limestone deposits | Short treatment with commercial deliming agent |
| Oily and greasy deposits | Cleaning agents based on water-soluble cleansers, such as household dish detergents |
| Other types of deposits | With water and soft brush |

Caution!

Do not touch optics with sharp-edged objects, do not scratch optics.

Supplemental documentation

Liquisys M CUM 223 / 253 transmitter
 ProbFit CUA 461 holder assembly
 DipFit W CYA 611 immersion holder
 CUA 120 / CUA 250 holder
 CYH 101 universal mounting assembly

TI 200C/24/ae
 TI 134C/24/ae
 TI 166C/24/ae
 TI 096C/24/ae
 TI 092C/07/en

For application and selection assistance,
in the U.S. call 888-ENDRESS

For total support of your installed base, 24 hours
a day, in the U.S. call 800-642-8737

Visit us on our web site, www.us.endress.com

United States

Endress+Hauser, Inc.
2350 Endress Place
Greenwood, IN 46143
Phone: (317) 535-7138
888-ENDRESS
FAX: (317) 535-8498

Canada

Endress+Hauser
Canada Ltd.
1440 Graham's Lane
Unit 1, Burlington
ON, L7S 1W3
Phone: (905) 681-9292
800-668-3199
FAX: (905) 681-9444

Mexico

Endress+Hauser
Paseo del Pedregal No. 610
Col. Jardines del Pedregal
01900, Mexico D.F.
Mexico
Phone: (525) 568-2405
FAX: (525) 568-7459

Endress+Hauser
The Power of Know How

