

OWNERS MANUAL

Chlorine Pocket Photometer
Field Portable

HF scientific, inc.
3170 Metro Parkway
Ft. Myers, FL 33916
Phone: 239-337-2116
Fax: 239-332-7643
Email: Info@hfscientific.com

Manual Part No. 21885 (12/03)
Rev. 1.2

DECLARATION OF CONFORMITY

Application of Council Directive

Standard to which Conformity is Declared:

Product Safety - Tested and passed CE EN61010-1:1990 + A1:1992 (73/32 EEC)

Immunity and Emissions – Tested and passed EN61326:1997 + A1:1998

Manufacturer's Name: HF scientific, inc.
Manufacturer's Address: 3170 Metro Parkway, Fort Myers, Florida 33916-7597
Type of Equipment: Field Portable Turbidimeter
Model No: MicroTPI

I, the undersigned, hereby declare that the equipment specified above conforms to the above Directive and Standard

Place: Fort Myers, Florida USA



(Signature)

Date: November 01, 2000

Robert J. Maley, President

Table of Contents

DECLARATION OF CONFORMITY.....	i
Specifications	1
1.0 Overview.....	2
1.1 Unpacking and Inspection of the Instrument and Accessories	2
1.2 The Display.....	3
1.3 The Instrument and Touch Pad.....	3
2.0 Safety.....	4
3.0 Normal Operation.....	5
3.1 Routine Measurement.....	5
4.0 Instrument Calibration.....	5
5.0 Troubleshooting	7
5.1 System Warning Messages	7
5.2 System Error Messages.....	7
5.3 Technical and Customer Assistance.....	8
6.0 Routine Maintenance.....	9
6.1 Cuvette Cleaning and Care	9
6.2 Battery Replacement	9
7.0 Accessories and Replacement Parts List	10
8.0 Warranty	11
8.1 Waterproof Seal.....	11
9.0 Glossary	12

Specifications

Measurement Range	0-6 mg/l (PPM) Trending 0-10 mg/l (PPM)
Resolution	0.01 mg/l
Regulatory Compliance	US Standard Methods EPA Approved
Response Time	Less than 5 seconds
Display	7 Segment Liquid Crystal Display
Operating Temperature Range	0°C – 50°C (32°F – 122°F)
Sample Temperature Range	0°C – 50°C (32°F – 122°F)
Relative Humidity	0-90% Non Condensing
Power Supply	4 – AAA Batteries (life is approximately 1000 readings using standard alkaline batteries)
Certification	CE
Insulation Rating	Pollution Degree 2
Approximate Dimensions	Instrument: 7 cm x 16.5 cm x 4.8 cm (2 ¾” x 6 ½” x 1 7/8”) Instrument in Minilab Case
Enclosure Rating:	NEMA 4X Designed to meet the specifications of IP67
Shipping Weight:	1.22 kg (2.70 lbs)
Shipping Dimensions:	28 cm x 30.5 cm x 7.6 cm (11” x 12” x 3”)
Warranty	1 Year from date of shipment

1.0 Overview

The Chlorine Pocket Photometer (the instrument hereafter) allows you to measure the concentration of chlorine in water and is designed to meet the specifications set out in standard methods.

1.1 Unpacking and Inspection of the Instrument and Accessories

You should find the following items in your shipment.

Item	Quantity
Pocket Photometer with 4 AAA batteries installed	1
Instruction Manual	1
Instrument Carrying Case	1
Disposable Cuvettes with Caps	4
PPD-2 Powder Pop Dispenser	1

Remove the instrument from the packing carton. Carefully inspect all items to ensure that no visible damage has occurred during shipment. If the items you received do not match your order, please immediately contact your local distributor or the HF scientific, inc. Customer Service department.

Warning: Extra care should be taken when handling the disposable cuvettes: surface scratches or finger smudges on the cuvette surface may cause measurement errors. Handle these items only by the ridged sides; do not touch the clear optical sides.

Note: The instrument is shipped with the batteries installed.

Figure 1 is a depiction of the top of the instrument. The three main components of the instrument are the sample well, the display, and the touch pad. The proper use of the instrument and the sample well will be discussed in later sections.

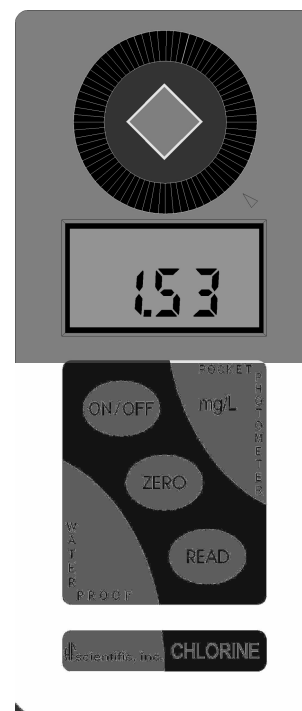

Figure 1

Figure 2 is a depiction of the PPD-2 Powder Pop Dispenser. The following sections will describe the functionality of the Dispenser and its relationship with the Pocket Photometer.

The Powder Pop Dispenser is an important accessory to the instrument, providing convenient and accurate doses of DPD reagent on demand.

To use the Dispenser, simply flip the protective cap out of the way, invert the dispenser and shake gently, place over the top of the cuvette then firmly, depress the Dispenser button to deliver the reagent. The protective cap should be replaced after use.

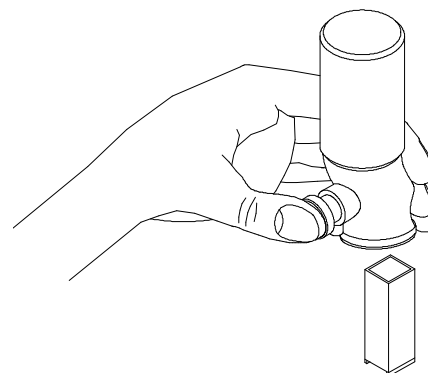

Figure 2

1.2 The Display

All of the items that can appear on the display are shown in Figure 3. The display is used for reporting the chlorine concentration level and to provide user guidance. The display also has other icons that are used to communicate various messages.

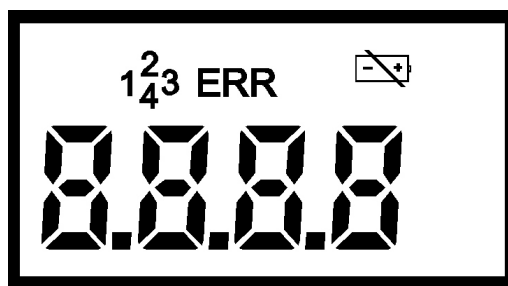

Figure 3 – Display used in the instrument.

1.3 The Instrument and Touch Pad (see Figure 1)

The touch pad has three buttons: **ON/OFF**, **ZERO**, and **READ**. The **ON/OFF** button is used to turn the instrument on and off. The **ZERO** button is used to establish a base reading (**ZERO**) for the water to be tested. The **READ** button is pressed to take a reading after color has been developed in the sample.

2.0 Safety

This manual contains basic instructions that you must follow during the operation, care and maintenance of the instrument. The safety protection provided by this equipment may be impaired if it is used in a manner not described in this manual. It is recommended that all operators should read this manual prior to working with this instrument.

In certain instances **NOTES**, or helpful hints, have been highlighted to give further clarification to the instructions. Refer to the *Table of Contents* to easily find specific topics and to learn about unfamiliar terms.

3.0 Normal Operation

This instrument allows you to measure the concentration of free or total chlorine in a grab sample of water. Readings are reported in milligrams per liter mg/l which are numerically equivalent to parts per million (PPM). The stated range of the instrument is 0-6 mg/l within the stated accuracy; however, the instrument will trend or read to 10 mg/l.

During normal operation, the instrument will display a variety of signals.

After Pressing **ON/OFF** Button



After Pressing **Zero** Button

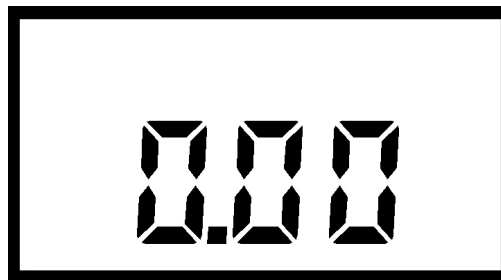

3.1 Routine Measurement

The instrument measures and reports the concentration of free or total chlorine of a sample in milligrams per liter (mg/l).

Note: Milligrams per liter (mg/l) are numerically equivalent to parts per million (PPM).

1. Turn on the instrument by pressing the **ON/OFF** button continuously for 1 second until the display light up.

STEP 1-ZERO the instrument

- a. Rinse a sample cuvette three times with a sample of the water to be measured. After rinsing, fill the cuvette to within 1/2" of the top. Do not overfill. Wipe off any water making sure that the sides and bottom of the cuvette are dry and that the optical sides are clean.
- b. Place the cuvette in the optical well with one of the clear optical sides facing the indicating arrow.
- c. Press the **ZERO** button.

STEP 2 – Add Reagent to the sample

- a. Remove the cuvette with the sample from the instrument.
- b. Invert the PPD-2 Powder Pop Dispenser and shake gently to ensure that the proper amount of reagent is available. Remove the "snap cap" from the Dispenser bottom,

place the Dispenser over the top of cuvette. Fully and firmly, depress the Dispenser button to discharge the reagent.

- c. Mix the reagent in the water sample by capping the cuvette and inverting it at least three times.

STEP 3 - Measure the Chlorine Concentration.

- a. Replace the cuvette in the optical well with one of the optical sides facing the indicating arrow.
- b. If testing for Free Chlorine, immediately press the **READ** button and note the concentration.
- c. If testing for Total Chlorine, wait two minutes for the completion of the chemical reaction between the sample and the reagent. Press the READ button and note the concentration.

If additional samples are desired of the same sample water, step 1 can be omitted prior to turning the instrument off.

Warning: NEVER pour liquid directly into the sample well of the instrument always use a cuvette.

Note: The instrument will turn off after approximately 5 minutes if no buttons are pressed.

4.0 Instrument Calibration

The instrument was calibrated and tested prior to leaving the factory and is suitable for accurate use directly out of the box.

A 2.0 mg/l (2PPM) check standard is available which allows the user to periodically check the instrument calibration.

5.0 Troubleshooting

The instrument routinely performs self-diagnostics, and will automatically generate messages to provide you with specific diagnostic information.

5.1 System Warning Messages

Automatic warning messages are generated to provide you with specific diagnostic information about the instrument. These messages are for your use and do not indicate a reduction in the performance of the instrument or a failure of any component in the instrument.

Battery Symbol: A battery on the display indicates that the batteries need to be replaced. Under this condition, you should replace the batteries as soon as possible to ensure that the instrument will continue to function properly. A flashing battery symbol indicates that the batteries will fail very shortly. If the batteries get too low to accurately measure, the instrument will turn off. The instrument might not turn back on until the batteries have been replaced. See section 6.2 for more information

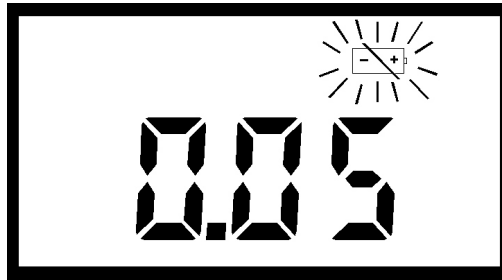

5.2 System Error Messages

There are two conditions for errors if the ERR icon is lit after turning the instrument on, the onboard diagnostics have determined that there is a system error. Call HF Technical Services for assistance as shown below.

If the case is the large word Err, the problem is usually due to an improper zero. Turn the instrument off and repeat the three steps outline in section 3.0.

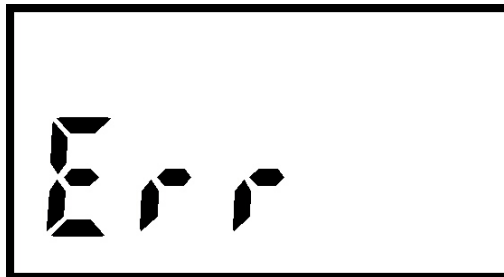

If the reading displays a flashing 10.0, the reading is over the measurement range of this instrument.

5.3 Technical and Customer Assistance

If you need assistance regarding this instrument please contact the HF scientific, inc. Technical Service Department.

HF scientific, inc.
3170 Metro Parkway
Fort Myers, Florida 33916-7597
Phone: (239) 337-2116
Fax: (239) 332-7643
Email: info@hfscientific.com

6.0 Routine Maintenance

If you do not plan on leaving the instrument in the supplied carrying case, when not in use, ensure that the instrument has been turned off and that a clean sample cuvette fitted with a black cap has been placed in the sample well. This will reduce the amount of dust and/or debris will be able to settle on the optics of the instrument.

6.1 Cuvette Cleaning and Care

Proper measurement of colorimetric, samples requires the use of cuvettes that are free of marks, smudges, scratches and any bacterial growth.

The instrument is supplied with 4 disposable plastic cuvettes. Please note that these cuvettes have ridges on opposing sides for finger grip and optically clear sides that are used for measurement. The optical sides must be kept clean. If the cuvettes become stained or scratched, replace the cuvette.

6.2 Battery Replacement

The instrument will periodically require new batteries to function properly. This will be indicated with a flashing battery indicator on the display. To replace the batteries:

1. Turn the instrument off and place it upside down on a soft surface.
2. Remove the two screws (A) securing the battery cover (B). Lift cover off.
3. Remove the old batteries. Place four new AAA batteries (C) into the battery compartment (ensuring the correct polarity).
4. Replace the battery cover and fasten the two screws carefully to ensure a watertight seal.
5. Dispose of used batteries in accordance with all federal, state and local regulations.

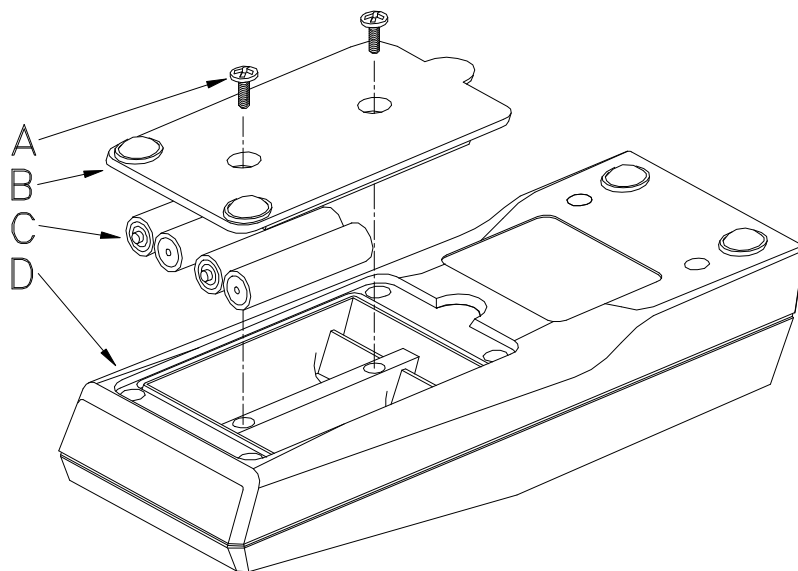

Figure 3: Detailed view of the battery compartment

7.0 Accessories and Replacement Parts List

The items shown below are recommended accessories and replacement parts for the instrument.

Accessory	Catalog Number
PPD-2 Powder Pop Dispenser Free (100 tests)	10500
PPD-2 Powder Pop Dispenser Total (100 tests)	10502
PPD-2 Powder Pop Dispenser Free (1000 tests)	10500C
PPD-2 Powder Pop Dispenser Total (1000 tests)	10502C
Disposable Cuvettes with Caps (Package of 30)	10431
Reference Standard Solution (2PPM)	10451A
Operators Manual	21885
Rechargeable Battery Kit	19859

To order any accessory or replacement part, please contact the HF scientific, inc. Customer Service Department. See section 5.3 for contact information.

8.0 Warranty

The manufacturer warrants to the original purchaser of this instrument that it will be free of defects in material and workmanship, in normal use and service, for a period of one year from date of delivery to the original purchaser. The manufacturer's obligation under this warranty is limited to replacing, at its factory, the instrument or any part thereof. Parts, which by their nature are normally required to be replaced periodically, consistent with normal maintenance, specifically lamps including fluorescent backlight, reagent, desiccant, sensors, electrodes and fuses are excluded. Also excluded are accessories and supply type items.

Original purchaser is responsible for return of the instruments, or parts thereof, to the manufacturer's factory. This includes all freight charges incurred in shipping to and from the manufacturer's factory.

The manufacturer is not responsible for damage to the instrument, or parts thereof, resulting from misuse, negligence or accident, or defects resulting from repairs, alterations or installation made by any person or company not authorized by the manufacturer.

The manufacturer assumes no liability for consequential damage of any kind, and the original purchaser, by placement of any order for the instrument, or parts thereof, shall be deemed liable for any and all damages incurred by the use or misuse of the instruments, or parts thereof, by the purchaser, its employees, or others, following receipt thereof.

Carefully inspect this product for shipping damage, if damaged, immediately notify the shipping company and arrange an on-site inspection. The manufacturer cannot be responsible for damage in shipment and cannot assist with claims without an on-site inspection of the damage.

This warranty is given expressly and in lieu of all other warranties, expressed or implied. Purchaser agrees that there is no warranty on merchantability and that there are no other warranties, expressed or implied. No agent is authorized to assume for the manufacturer any liability except as set forth above.

8.1 Waterproof Seal

Opening the main instrument enclosure (excluding the battery compartment) may void the warranty.