

## **SWOFFER INSTRUMENTS, INC.**

### *MODEL 2100 SERIES CURRENT VELOCITY METERS*

#### *Instructions for Operation and Maintenance of 2100 Indicator\**

### **INDICATOR FEATURES and OVERVIEW**

The *Model 2100* Current Velocity Meter provides stream current measurements from 0.1 to 25 feet per second by reading directly in feet or meters per second. Velocity is shown on a liquid crystal display readout and units of measure are selected by a toggle switch located in the battery compartment at the back of the indicator.

The display has three averaging periods as selected by the rotary switch. These averaging periods range from a minimum time of about 5 seconds to a maximum time of about 90 seconds. The liquid crystal display holds the average velocity for the most recent update period until the end of the next period when a new average velocity will appear in the display and hold.

The *Model 2100* Indicator is powered by a single 9-volt battery, which also supplies power to the photo-diode and the phototransistor in the sensor. A 2-inch propeller drives a rotor containing two fiber-optics bundles. The rotation of these fiber-optics bundles gates infrared light from the photo-diode to the phototransistor creating a pulse rate that is proportional to the propeller RPM. The pulses are counted and stored then compared to a quartz crystal oscillator and processed to display velocity.

The *Model 2100* Indicator can be calibrated in the field and corrections can be made for optimum accuracy at the velocities most often encountered. Velocities below about 1 foot per second require some minor calibration adjustments, which will be discussed later in the CALIBRATION section. **READ IT CAREFULLY.**

The battery compartment at the back of the indicator can be opened by use of the four thumbscrews at the corners of the case back. Space in the compartment is provided for both the operating battery and a spare plus there are cutouts in the foam lining for those accessories required for the particular Model being used.

The *Model 2100* Indicator is water sealed at the case front and at the bottom in the battery compartment. The battery compartment itself is not watertight however, and can fill with water if the indicator is immersed. The indicator will float even with the battery compartment filled because the foam lining is closed-cell and will not absorb moisture except on its surface.

The electrical connector between the sensor and the indicator is water-resistant only when mated. The connector is keyed and locks with a twist of the knurled collar.

A neck strap is furnished with the *Model 2100* and it clips to the loops located at the top and bottom ends of the indicator.

\* Separate instructions are provided for operating the specific type of sensor and wand shipped with the 2100 Indicator

## QUICK OPERATING INSTRUCTIONS FOR THE MODEL 2100

All *Model 2100* instruments regardless of the complete Model Number operate in the following manner:

1. Remove the sensor protection cap (if used) and install the propeller rotor using the Rotor Installation Wrench (1/16" Allen wrench). This setscrew need only be snug, do not over-tighten it ! Damage to the sensor can result.
2. Connect the Sensor Wand to the *Model 2100* Indicator by using the twist lock electrical connector.
3. Rotate the Indicator selector switch to the **CALIBRATE** position. The display should read about **186** (feet per second mode) or **610** (meters per second mode). Change to whichever unit of measure is wanted by use of the FEET/METERS switch located inside the battery compartment.
4. Rotate the selector switch to the **COUNT** position. Spin the propeller and confirm that the indicator reads increasing counts (sensor output pulses) as the propeller spins. There should be four counts per revolution. (The spin test is described later in the calibration instructions)
5. Rotate the selector switch to the minimum update time. (First position from the left side **OFF** position).
6. Place the sensor in the stream with the propeller facing into the flow.
7. Press and release the **RESET** button to zero the display.
8. The next figure, which appears on the display, will be the stream velocity. That velocity will remain on the display until the next update period ends. The figure in the display will always be the velocity of the last averaging period. (The indicator **does not** provide a "moving average").

\*For specific instructions for your *Model 2100* see the documentation for the wand assembly that came with your current meter.

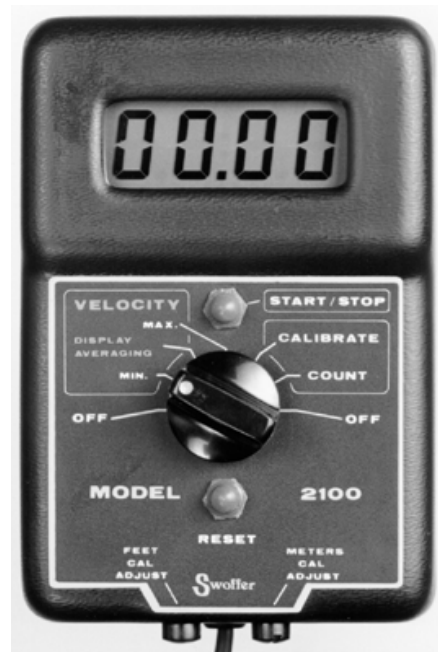

## CARE AND MAINTENANCE OF THE MODEL 2100 INDICATOR

Should the indicator fall into the stream, open the battery compartment as soon as possible and dry the battery terminals and the cable connections. Since the foam lining is closed-cell, water will not absorb into more than just its surface. Allow the compartment to air dry or use a hair dryer if available before replacing cover.

Always make sure that the calibration adjustment cover screws located at the bottom end of the indicator are tightly fitted. These provide **DIRECT ACCESS TO THE CIRCUIT BOARD** and if loose, will allow water to enter the indicator.

Clean the indicator only with a solution designed for plastics. The indicator lens is made of acrylic and can be easily scratched if an abrasive cloth is used. The indicator case is ABS and there are many chemicals which act as solvents for ABS, severely affecting its appearance if they make contact. Use caution when cleaning.

Periodically check the condition of the pins and sockets in the connector. Keep the contacting surfaces clean and bright and make sure the pins are not bent and that the sockets still fit the pins snugly. Although the connection cable is rugged, avoid sharp bending and re-bending and **DO NOT SUSPEND THE WAND OR INDICATOR BY THE CABLE**.

Extreme temperatures will effect the *Model 2100* Instrument. At below freezing temperatures the liquid crystal display becomes sluggish making response time slow. Some "ghosting" of unused digit segments may also be noticed. This condition is only temporary and the instrument will operate normally after temperatures rise to normal operating levels.

The battery is also affected by low temperatures and may not have enough power to bring the calibration numbers up to the correct level for accurate measurement. Check calibration number frequently when working in low temperatures. For best results keep the indicator close to the body inside your coat during operation in the cold. Keep extra batteries in your coat and exchange them often.

High temperatures and direct sunlight will also effect the operation of the *Model 2100*. **DO NOT LEAVE THE INDICATOR IN A CLOSED VEHICLE IN THE SUN**. Cover the indicator and avoid prolonged exposure of the liquid crystal display to ultra-violet rays. Ultra-violet will eventually degrade the display requiring its replacement.

High temperatures may also cause the indicator electronics to give erroneous readings due to pulse-count-timing errors.

*In short, keep the Model 2100 within the recommended operating temperatures for optimum results.*

<b>NORMAL OPERATING TEMPERATURE</b>	<b>77°F (25°C)</b>	
<b>MIN. TEMP (FOR RELIABLE OPERATION)</b>	<b>-14°F (-25.56°C)</b>	
<b>MAX. TEMP.</b>	<b>180°F (82°C) @ LESS THAN 15%</b>	<b>RELATIVE HUMIDITY</b>
	<b>120°F (49°C) @ LESS THAN 95%</b>	<b>RELATIVE HUMIDITY</b>

## BATTERY CONDITION AND ITS EFFECTS ON THE MODEL 2100

The battery, which powers the Model 2100, is a single alkaline type 9-volt transistor cell. This battery powers both the indicator electronics and the sensor photo-diode/transistor circuitry. **The indicator alone draws very little current, however the sensor circuit (if allowed to remain on constantly) can drain a fully charged**

**battery in a short time.** Depending on your use of the *Model 2100*, a fresh battery can last as long as several months or as short as a few days. Be sure to return the selector switch to one of the "OFF" positions after each measurement has been taken and to always have a fresh spare battery on hand.

One way to determine battery strength is to check the Calibration Number held by the indicator. Rotate the selector switch to the calibrate position. If the displayed calibration number is much less than it should be then the battery should be replaced. **NOTE:** This test is only valid with the sensor connected to the indicator and the rotor positioned so that the optics trigger an "on" condition. Only then is maximum battery drawdown achieved.

*In no case should you use a battery with less than 5 volts remaining.* Below the threshold of about 5 volts the battery will operate the indicator electronics **but not the sensor circuit.** The sensor will not be able to transmit a signal to the indicator or will transmit only an occasional signal, which will give erroneous readings. This is also relative to the manufacturing date of the Model 2100 sensor. Sensors produced later than mid 1992 require much less power for operation than earlier units and can be used at lower voltages.

Mid-stream sensor "wink out" can usually be avoided by occasionally checking the sensor output. Spin the propeller while the indicator is in the COUNT mode. If the display counts up the sensor pulses as the rotor spins then the battery can be considered acceptable. There are four counts per revolution. (One revolution of the propeller must produce 4 counts on the LCD).

*Errors in measurements due to battery voltage drop (and subsequent CALIBRATION NUMBER drop) will be in direct percentage proportion to the difference between the "ideal" calibration number and the displayed calibration number.*

## CALIBRATION OF THE MODEL 2100 CURRENT METER

The *Model 2100* Current Meter is designed to be easily calibrated by the user. This calibration must be done with each Rotor you use. *The calibration numbers recommended by SWOFFER INSTRUMENTS, INC. are not necessarily correct for all measuring situations, therefore for optimum accuracy the user should calibrate the rotors before use and at or near to the velocities expected to be encountered.*

**If very accurate velocity measurements are required then you must calibrate your *Model 2100* system and check the calibrations often.** The instructions below should be followed very carefully for reliable measurements using the *Model 2100*.

**IMPORTANT NOTE:** "Calibrating a sensor" is actually calibrating a particular propeller rotor for use with the *Model 2100* Indicator. If you use more than one rotor assembly you must check the calibration for *each* rotor assembly and adjust the Indicator Calibration Numbers accordingly as you switch from one propeller assembly to another.

Calibration numbers correctly matching a rotor assembly to a 2100 indicator are especially important at the lower velocities (1.5 FPS and lower) and can vary greatly depending on many factors; bearing surface condition in the rotor, make-up of the water being measured (amount of suspended particulates), any damage to the propeller, rotor, shaft, thrust-bearing nut, etc.

### **What a calibration number is:**

The *Model 2100* rotors produce four pulses per revolution. Each of the four fiberoptic "eyes" in the rotor triggers an electrical pulse from the sensor. These pulses are called "Counts" and are read by the *Model 2100* Indicator. The Indicator uses these counts, measuring the number of them against an internal timer to determine velocity. The two calibration numbers therefore represent the number of counts a specific rotor produces as it travels through 10 feet and 10 meters of still water. When the sensor is *stationary* and water is moving past the propeller, a specific number of counts produced in a specific amount of time determines velocity when you know

how many counts are produced per foot or meter (pitch). The calibration numbers can also be referred to as Pitch.

Although rotor/propeller combinations are “similar” they are not necessarily “identical” and therefore each may have a slightly different Calibration Number. Always remember that the Calibration Numbers shown on the Indicator’s display represent the Calibration Numbers for a single rotor assembly only. Double check any and all rotor assemblies used for a measuring job and make sure that each is within your accepted tolerance for calibration variation. Only go out into the field with specific knowledge of each rotor assembly’s calibration number. Make sure that the calibration number shown on the 2100 Indicator matches the calibration number of the rotor that is attached to the sensor before relying on any readings.

**CHECKING AND CHANGING CALIBRATION OF THE MODEL 2100**

Before applying corrections to the *Model 2100* rotate the selector switch to the **CALIBRATE** position. A figure will appear in the display and will be either the FEET calibration number or the METERS calibration number depending on the position of the FEET/METERS switch (located in the battery compartment). For most measuring applications the calibration numbers will be *about*:

<b>FEET</b>	=	<b>186</b>
<b>METERS</b>	=	<b>610</b>

If the displayed figures are much lower than these figures the first thing to check is the battery. A weak battery can allow the indicator calibration numbers to "drift" downward slightly and will cause errors in measurements. Be sure to connect the sensor to the indicator when confirming battery strength. Always keep a *full charge* 9-volt battery in the compartment as a spare.

*NOTE: It is important to note that errors in measurements due to Calibration Number variation will be in direct percentage proportion to the difference between the ideal (correct) Calibration Number for any rotor assembly and the number that the indicator displays.*

*Example: If the ideal number is 186 for a particular rotor assembly and the Indicator-displayed number is 184 then the velocity error due to calibration error will be about 1%.*

To determine a reliable calibration number for your *Model 2100* perform the following: This is something you **must** do if you are working with slow flows (below about 1.5 FPS) and for measurements taken in very shallow streams.

Mark a straight course of 10 to 20 feet in length in a body of calm, current-free water along which the sensor can be towed by walking the course (a shorter length course can be satisfactory as well). A swimming pool or dock into a quiet lake serves well. Rotate the selector switch to the **COUNT** position. If the display does not show all zeros press and release **RESET**. (The decimal point does not show in the count mode.)

Place the sensor in the water a few feet before the beginning of the course, 6 to 12 inches below the surface. Begin walking the sensor through the course at a rate close to that which you will be measuring. (If shallow flows are to be encountered try to duplicate those conditions when making calibration checks.) Using the wand rather than the sensor as a guide, press and release the **RESET** button at the instant the wand enters the course. The indicator will begin counting the number of sensor pulses generated as you walk. At the instant the wand leaves the course press and release the **START/STOP** button. The display now shows (and will hold) the number of pulses generated through the course length. Several passes through the course in both directions are recommended to develop a reliable average figure. Press and release **RESET** each time a run is completed to re-zero the display.

Determine the average number of pulses generated through the course. If your course length is not 10 feet, compute the number of pulses that the sensor would generate if the course were exactly 10 feet. This will be the **CALIBRATION NUMBER** that the *Model 2100* Indicator should hold for accurate measurements with that rotor assembly (in feet per second):

$$\text{FEET CAL. No.} = \frac{10 \times \text{AVERAGE No. OF PULSES}}{\text{COURSE LENGTH (IN FEET)}}$$

This number can then be multiplied by 3.281 (the number of feet in one meter) to determine the calibration number for meters.

Next, rotate the selector switch to the **CALIBRATE** position. Put the **FEET/METERS** switch (in battery compartment) in the FEET position and the indicator will display the Calibration Number it presently holds for measuring in Feet Per Second. With a good battery it should be 180-186 (2" props only). If your derived Calibration Number is different from the number displayed you can change the calibration number by using the **CAL ADJUST** screw(s) at the bottom end of the indicator. Remove the **CAL ADJUST** cover screws (black plastic fillister-head screws).

USING ONLY A JEWELER'S SCREWDRIVER (to prevent damage to the adjustment screw) rotate the screw clockwise to increase the displayed number and counterclockwise to decrease the number. Do the same for the Meters calibration number.

Each calibration adjustment screw is a 15-turn potentiometer with very fine resolution and plenty of latitude for normal adjustment given a full charge 9-volt battery.

**REPLACE THE ADJUSTMENT COVER SCREWS AFTER MAKING CALIBRATION CORRECTIONS. INDICATOR IS NOT WATER RESISTANT WITHOUT THESE COVER SCREWS IN PLACE!**

Note and store *with the Model 2100 Indicator* your new Calibration Number(s). Every time the instrument is used the calibration numbers and rotor assembly(s) that generated it must be confirmed (rotate switch to **CALIBRATE**) before relying on readings. Be sure to check the calibration number with the sensor connected to the indicator to achieve maximum battery current draw.

**IMPORTANT:** Errors in measurements due to Calibration Number variation will be in direct percentage proportion to the difference between the ideal (correct) Calibration Number and the number that the indicator displays.

## MODEL 2100 SERIES CURRENT METER-INDICATOR FUNCTION SWITCH

### **OFF & OFF**

Redundant positions. Cuts all power from battery to the indicator and the sensor.

### **VELOCITY**

Three display averaging switch positions; from the minimum display update time to the medium to the maximum. The LCD displays and holds the stream velocity for the previous update time until the next averaging period is completed. Update times vary with the selection of FEET or METERS and also vary with the value of the calibration numbers held by the indicator. *Approximate* update times are as follows:

	FEET	METERS
<i>MIN</i>	10 SEC	1.5 SEC
<i>(Med)</i>	20 SEC	6.0 SEC
<i>MAX</i>	90 SEC	30.0 SEC

**START/STOP**

Used mainly when calibrating. Begins and ends **COUNT** function. Display will hold data until **RESET** is pressed.

**RESET**

Resets the display to zero. Will operate in any rotary switch position (except OFF). Used to begin timing functions at "time zero" (i.e. the first reading after the rotary switch has been shifted to a new position may not be accurate. Use of the **RESET** switch will eliminate "first averaging period" timing errors.

**CALIBRATE**

LCD will show the figure that the indicator holds as the "Calibration Number". The **FEET-METERS** switch in the battery compartment is used to change the displayed number from feet to meters. See CALIBRATION INSTRUCTIONS.

**COUNT**

Indicator counts and displays the number of sensor output pulses generated. Used when calibrating the *Model 2100*.

**FEET/METERS**

Toggle switch located inside the battery compartment. Changes the indicator readout between meters per second and feet per second.

**CALIBRATION ADJUST**

Removing the plastic, fillister-head screws at the bottom end of the indicator provides access to the Calibration Adjustment Screws. With the rotary switch in the **CALIBRATE** position the displayed figure can be altered by turning the adjustment screws. Clockwise rotation increases the calibration number. Use only a jeweler's screwdriver when making adjustments to prevent damage to the calibration adjustment screws. The plastic screws must be replaced after adjustments to preserve the water-resistance of the Indicator.

***SWOFFER INSTRUMENTS, INC.***  
***1048 INDUSTRY DRIVE***  
***SEATTLE, WA 98188 USA***  
***FAX (206) 575-1329***

# MODEL 2100-1514 and 2100-1518 CURRENT METER

## SUSPENSION WAND OPERATING AND MAINTENANCE INSTRUCTIONS

### GENERAL DESCRIPTION

The above part numbered devices consist basically of a 1" diameter aluminum tube 12 feet in length (metric version, 2100-1518, is 4 meters in length). The tube is marked in feet and tenths or in meters with 5cm graduations. The graduations begin at the bottom end of the tube. A sliding/locking device (**2100-151-Slider**) positions the Model 2100 Sensor anywhere along the tube and locks the sensor firmly in place while taking measurements. The tube breaks down by means of threaded fittings into four equal-length sections. The Sensor/Cable assembly (**2100-A22**) slips easily in and out of the SLIDER for transporting and storing the sensor wand. The sensor wand fits into a PVC tube supplied for transportation and storage.

### INSTRUCTIONS FOR USE

1. Place **SLIDER** onto a section of the tube orienting the sensor cable slot toward the top of the rod.
2. Thread the tube sections together as required for the desired depth measurements. (NOTE: Plastic "thread protectors" are installed when the wand is shipped and must be removed before wand assembly can take place. Keep the thread protectors for later use when the wand is taken apart for transport and storage.
3. Thread the **TOP CAP** onto the top section of the assembled wand. It will fit any section. The **TOP CAP** contains the directional pointer in a stored position (it also has spare 6-32 set screws and an allen wrench for use with the set screws). Grasp the knurl on the stored pointer and unscrew it from the **TOP CAP** then thread it into the horizontal "pointing position" in one of the two threaded holes provided.
4. The **SLIDER** is locked into position on the rod by use of the knurled nut located at the back of the slider. Do not tighten the nut excessively as it is not necessary for keeping the slider in position. The 10-32 screw located in the center of the locking nut may be used to attach a flow direction "streamer" if desired. Orient the slider in the same direction as the Top Cap pointer if the sensor will be in depths where you cannot see the propeller.
5. Insert the Model 2100 Sensor (2100-A22) in the Slider and lock it into place with the set screw. **BE SURE THAT THE SENSOR BODY IS PROPERLY ORIENTED SO THAT THE SET SCREW FITS ONLY INTO THE RECESS PROVIDED FOR IT.** Tightening the set screw on the sensor body in a place other than in the recess may damage the sensor or the cable.
6. After the Rotor (2100-A21) has been installed on the sensor body, loosen the **SLIDER** lock nut and point the propeller in the same direction as the pointer at the top of the wand. Move the slider to the desired measuring depth and tighten the lock nut.
7. Attach the **FOOT** to the bottom section of the wand by means of the ¼-28 stainless steel bolt. The **FOOT** has a hole in it (off center) which is designed for attaching a steadying lanyard when high flow rates make handling difficult.

### TAKING READINGS

1. Connect the 2100 Indicator to the Sensor by use of the twist-lock connector. Rotate selector switch to the **COUNT** position and spin propeller. Confirm that the display counts up sensor pulses (four per revolution) and that the propeller rotates very freely.
2. Rotate the Indicator Selector Switch to the velocity averaging position desired (Min, -, Max).



3. Place the sensor wand in the stream orienting the propeller into the flow.
4. The Model 2100 Indicator will display the stream velocity. (For more complete Indicator operating instructions see the accompanying **Model 2100 Indicator Operating Instructions.**)

## MAINTENANCE OF THE SENSOR WANDS

1. Never leave the tube sections threaded together after use. Normal corrosion of the aluminum material could "freeze" the joints and make disassembly difficult or impossible later. For best results keep the threads and the shaft below the threads **VERY CLEAN** and well lubricated with a medium weight oil or grease. Silicone grease or petroleum jelly will work.
2. Always make sure the threads as well as the bore of the mating section of the tube are **completely free of all dirt and other particles** before re-mating the sections. The fit is necessarily close at the joints so great care must be used when assembling the sections to prevent threaded parts from seizing. **NEVER FORCE PARTS TOGETHER !!**
3. Always replace the Thread Protectors after disassembly of the wand.
4. *Remove the Sensor from the Slider when transporting the wand to avoid damage to the Sensor and Rotor Assembly.*
5. Remove the Complete Rotor Assembly from the Sensor when transporting to prevent damage to the propeller and the Fiber-Optics Rotor.

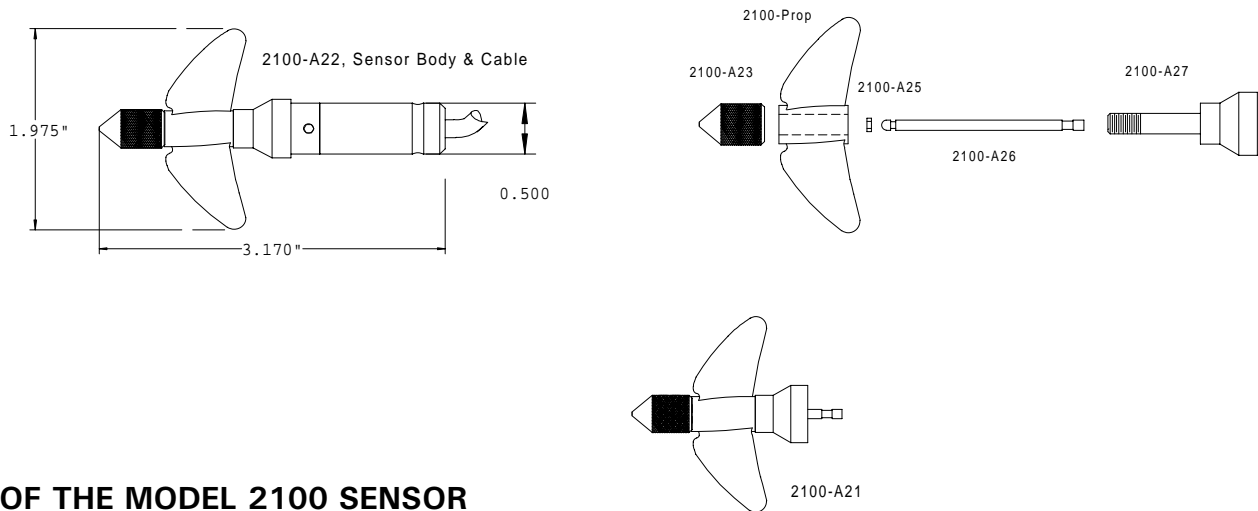

## CARE OF THE MODEL 2100 SENSOR

**The Sensor of the *Model 2100* Current Meter is the single most important part of the instrument and great care must be observed for its continued accurate output.**

Keep the Sensor/Propeller assembly above the stream bed when taking readings and avoid rocks and other hazards when moving from one measuring site to another. This will prevent damage to the Rotor, Rotor Shaft, Propeller and the Sensor Body.

***Never transport or store the sensor wand with the propeller rotor installed. Use the 1/16" hex screwdriver to loosen the setscrew and remove the entire rotor assembly when not using the Model 2100.*** Do not tighten the set screw any tighter than necessary to keep the rotor in place on the sensor. If too tight, the set screw can damage the surface of the rotor shaft causing it in turn to damage the inside of the fiberoptic rotor when it is removed for normal maintenance and cleaning.

Always replace the battery in the Model 2100 Indicator with a fresh one.

1. During rough use check the propeller frequently for frayed leading edges and for cracks. Chipped or cracked props should be replaced. Frayed leading edges can be brought back to acceptable levels of operation by reshaping them with 150 grit (or finer) sandpaper. Propellers which show signs of being bent or misshapen should be discarded.
2. Rotational friction is by far the biggest cause of erroneous data especially at velocities below 2 feet per second. Check the freedom of rotation frequently especially in turbid water or after rough handling. In some measuring situations it may be necessary to completely disassemble the rotor and clean the parts with clear water after each immersion. Use spare rotor assemblies and interchange them often. ***Never leave the rotor assembly attached to the sensor after taking readings.***
3. Water is the lubricant for the *Model 2100* rotor. "Canned air" and spray type degreasers should be used to regularly clean the "bore" of the Rotor (**2100-A27**) and the polished surface of the Rotor Shaft (**2100-A26**). Avoid oil & grease if possible.
4. The Rotor Assembly (**2100-A21**) should spin very freely when held in the vertical position (propeller pointing up) and simply blow lightly on the propeller. If it does not, clean the bore of the Rotor and the surface of the Rotor Shaft thoroughly.  
One method to determine an acceptable level of low-velocity performance by a particular Rotor Assembly is to perform a "Spin Test" :  
Install the Rotor on the sensor, connect the sensor to the Indicator, and place the Indicator in the **COUNT** mode. With the propeller pointing up blow very hard straight down on the propeller. *At the instant you stop blowing* hit the **RESET** button on the indicator and allow the rotor to coast to a stop. A rotor which will perform to the low velocity limits of its design produces counts on the indicator of at least 300.
5. If the Rotor begins to "buzz" when spun by hand it means that the bore diameter of the Rotor (**2100-A27**) and the outside diameter of the Shaft (**2100-A26**) are too far apart. In this case it is advised to replace the Rotor with a new one. If the shaft shows visible signs of wear replace it also. Severe buzzing indicates that the rotor is bouncing off the shaft as it rotates around it. This slows the rotor significantly especially at velocities above 3 FPS and will cause readings to be slower than actual. **Note:** Some slight buzzing may be heard in the later versions of the rotor when it is spun "dry". This buzzing should cause no significant loss of efficiency.
6. Periodically examine the Thrust-Bearing Nut (**2100-A23**) and check inside on the bottom (the bearing surface). If a pronounced "cup" begins to form (wear from the ball-shaped end of the Rotor Shaft) the **2100-A23** should be replaced. This is especially necessary when using the *Model 2100* in low-flow situations, 2 FPS or lower.
7. The Photo-Optics in the sensor body must be kept clean. Use soap and water and a soft tooth brush to keep the "eyes" clean if necessary. *Be careful and do not scratch the Photo-optics as this could cause unwanted light scattering and therefore erroneous readings.* Likewise the Fiber optics "eyes" in the base of the Rotor (**2100-A27**) should also be kept clean.

Treat the *Model 2100* Rotor Assembly and Sensor with care and it will continue to produce accurate data with minimum maintenance.

**SWOFFER INSTRUMENTS, INC.**  
1048 INDUSTRY DRIVE  
SEATTLE, WA 98188 U.S.A.  
FAX (206) 575-1329  
e-mail swoffer@swoffer.com  
(206) 575-0160

