

Metal Vane

ANEMOMETER

Model : YK-80AM

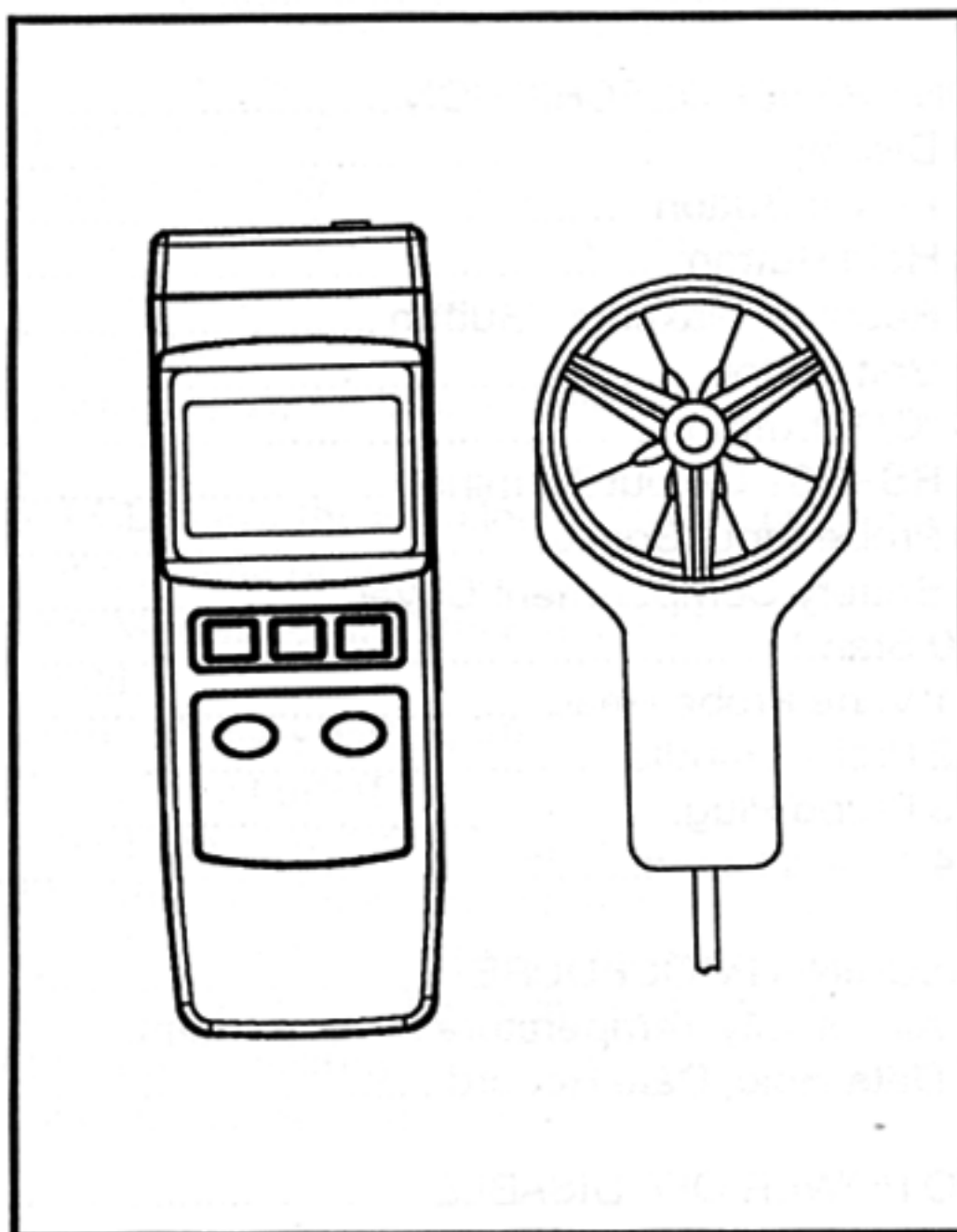

TABLE OF CONTENTS

1. FEATURES.....	1
2. SPECIFICATIONS.....	2
2-1 General Specifications.....	2
2-2 Electrical Specifications.....	3
A. Air velocity.....	3
B. Temperature.....	3
3. FRONT PANEL DESCRIPTION.....	4
3-1 Display.....	4
3-2 Power Button.....	4
3-3 Hold Button.....	4
3-4 Record (Max/Min) Button.....	4
3-5 Unit button.....	4
3-6 °C/°F button.....	4
3-7 RS-232 Output Terminal.....	4
3-8 Probe Input Socket.....	4
3-9 Battery Compartment/Cover.....	4
3-10 Stand.....	4
3-11 Vane Probe Head.....	4
3-12 Probe Handle.....	4
3-13 Probe Plug.....	4
3-14 Tripod fix nut.....	4
4. MEASURING PROCEDURE.....	5
4-1 Air velocity/Temperature measurement.....	5
4-2 Data Hold, Date Record.....	5
5. AUTO POWER OFF DISABLE.....	7
6. RS232 PC SERIAL INTERFACE.....	7
7. BATTERY REPLACEMENT.....	9

1. FEATURES

- * Metal vane probe, heavy duty & wide air velocity and temperature measurement.
- * Max air velocity measurement up to 40 m/s.
- * Microprocessor circuit assures maximum possible accuracy, provides special functions and features.
- * The portable anemometer provides fast, accurate readings, with digital readability and the convenience of a remote sensor separately.
- * Multi display units for air velocity measurement : m/s, km/h, ft/min, knots, mile/h.
- * Dual temperature display unit : °C and °F.
- * Low-friction ball vane wheels is accurate in both high & low velocity.
- * Thermistor sensor for Temp. measurement, fast response time.
- * Large LCD, show the air velocity and the temperature value at the same time.
- * Records Maximum and Minimum reading with recall.
- * Data hold.
- * Auto shut off saves battery life.
- * RS 232 PC serial interface.
- * Operates from 006P DC 9V battery.
- * Used the durable, long-lasting components, including a strong, light weight ABS-plastic housing case.
- * Wide applications: use this anemometer to check air conditioning & heating systems, measure air velocities, wind speeds, temperature...etc.

2. SPECIFICATIONS

2-1 General Specifications

Display	* 51 mm x 32 mm supper large LCD display. * Dual function meter's display.
Measurement	m/s (meters per second), km/h (kilometers per hour), ft/min (feet/per minute), knots (nautical miles per hour), mph (mile/h, miles per hour), Temp. – °C, °F., Data hold.
Sensor Structure	<i>Air velocity sensor :</i> Metal diecasting structure. Conventional twisted vane arms and low-friction ball-bearing design.
	<i>Temperature sensor :</i> Precision thermistor.
Circuit	Custom one-chip microprocessor LSI circuit.
Memory Recall	Records Maximum and Minimum readings with recall.
Power off	Manual off by push button or Auto shut off after 10 minutes (Not activated during memory record function).
Data Output	RS 232 PC serial interface.
Over load indication	Indicated by "– – – –".
Operating Temperature	<i>Meter :</i> 0 °C to 50 °C (32 °F to 122 °F).
	<i>Vane Probe :</i> 0 °C to 60 °C (32 °F to 140 °F).

Operating Humidity	Max. 80% RH.
Power Supply	Heavy duty type DC 9V battery, 006P, MN1604(PP3) or equivalent.
Power Current	Approx. DC 8.3 mA.
Weight	220 g/0.48 LB.
Size	<i>Main instrument:</i> 200 x 68 x 30 mm (7.9 x 2.7 x 1.2 inch). <i>Sensor Head:</i> Round, 72 mm Dia.
Accessories	Instruction manual..... 1 PC. Metal Vane probe..... 1 PC. Carrying case..... 1 PC.

2-2 Electrical Specifications

A. Air velocity

Measurement	Range	Resolution	Accuracy
m/s	0.8 – 40.0 m/s	0.1 m/s	±(2 % + 1d)
km/h	2.8 – 144.0 km/h	0.1 km/h	
mph	1.8 – 89.4 mph	0.1 mph	
knots	1.6 – 78.1 knots	0.1 knots	
ft/min	160 – 4930 ft/min	1 ft/min	±(2 % + 20ft/min.)

Note:

m/s – meters per second km/h – kilometers per hour
ft/min – feet/per minute knots – nautical miles per hour
mph – miles per hour (international knot)

B. Temperature

Measuring Range	0 °C to 60 °C/32 °F to 140 °F
Resolution	0.1 °C/0.1 °F
Accuracy	0.8 °C/1.5 °F

Remark :

Above specification are tested under the environment RF Field Strength less than 3 V/M & frequency less than the 30 MHz only.

3. FRONT PANEL DESCRIPTION

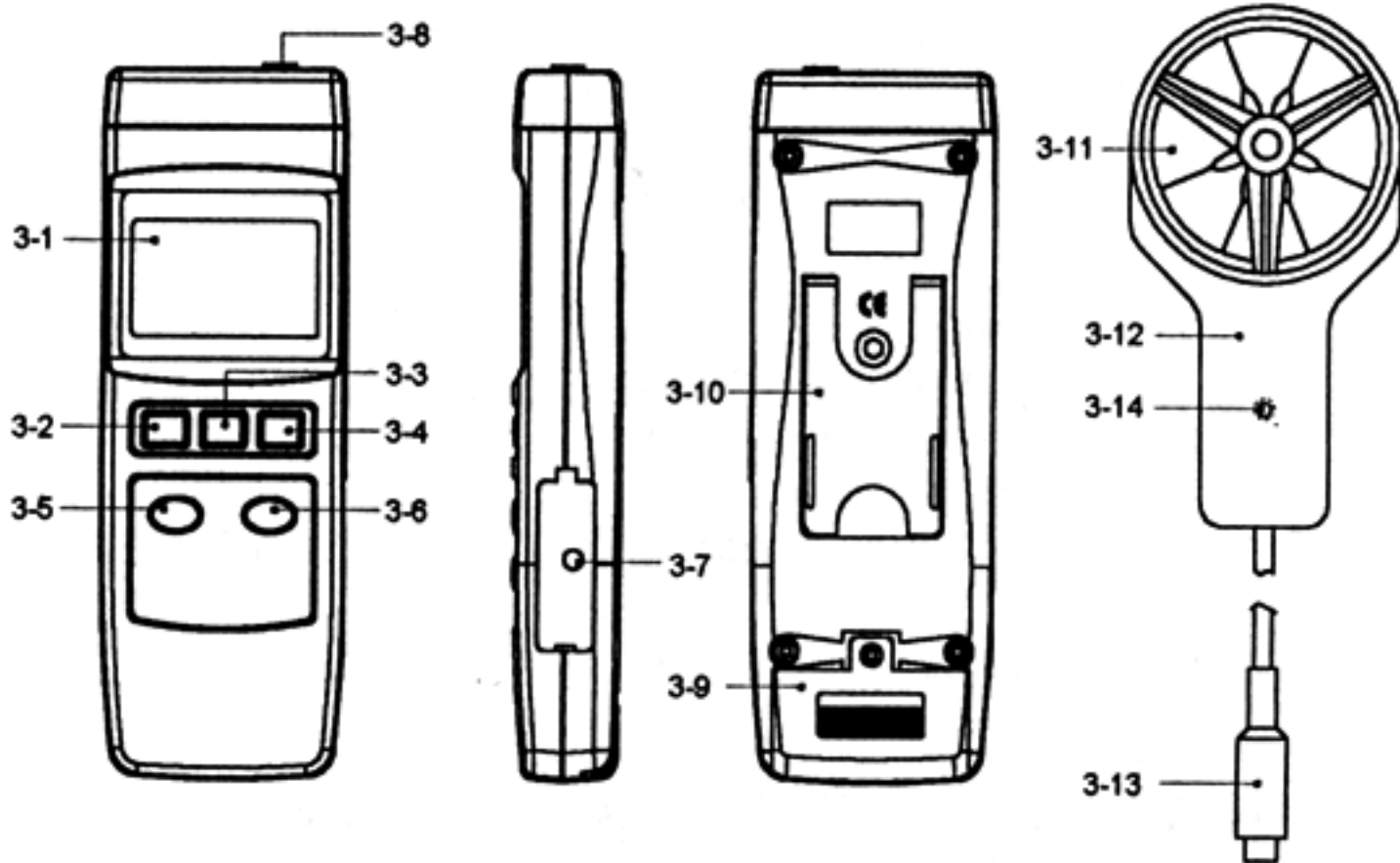



Fig. 1

- | | |
|-------------------------------|-------------------------------|
| 3-1 Display | 3-8 Probe Input Socket |
| 3-2 Power Button | 3-9 Battery Compartment/Cover |
| 3-3 Hold Button | 3-10 Stand |
| 3-4 Record (Max/Min) Button | 3-11 Vane Probe Head |
| 3-5 Unit button | 3-12 Probe Handle |
| 3-6 °C/°F button | 3-13 Probe Plug |
| 3-7 RS-232 Output Terminal | 3-14 Tripod fix nut |

4. MEASURING PROCEDURE

4-1 Air velocity/Temperature measurement

- 1) Install the " Probe Plug " (3-13, Fig. 1) into the " Input Socket " (3-8, Fig. 1).
- 2) Power ON the meter by pressing the " Power Button " (3-2, fig. 1).
- 3) a. Select the desired air velocity unit (m/s, km/h, mph, knots, ft/min) by pusing the " unit Button " (3-5, fig. 1).
b. Select the desired temperature units by pusing the " °C/°F Button " (3-6, fig. 1).
- 4) Use the hand (or tripod installation) to hold the " Probe Handle " (3-12, Fig. 1), face the " Vane Probe Head " (3-11, Fig. 1) to the measured wind. In the same time the air velocity and the temp. value will show on the LCD display.

* *The Vane probe that stick a label "  " is the right face that should toward the measured wind.*

4-2 Data Hold, Date Record

- 1) Data Hold
 - a. During the measurement, pushing the " Data Hold Button " (3-3, Fig. 1) will hold the measured value & the LCD will indicate " HOLD " symbol.
 - b. Push the " Data Hold Button " again to release the data hold function.
- 2) Data Record (Max., Min. reading)
 - a. The data record function records the maximum and minimum readings. Press the " REC. Button " (3-4, Fig. 1) to start the Data Record function and there will be a " REC " symbol on the display.

b. With the " REC " symbol on the display :

- * Press the " REC Button " (3-4, Fig. 1) once, the " REC Max " symbol along with the maximum value will appear on the display.

Note :

If intend to delete the maximum value, just press " Hold Button " (3-3, Fig. 1) for a while, and then the display will show the " REC " symbol only & execute the memory function continuously.

- * Press the " REC. Button " (3-4, Fig. 1) again, the " REC Min " symbol along with the minimum value will appear on the display.

Note :

If intend to delete the minimum value, just press " Hold Button " (3-3, Fig. 1) for a while, and then the display will show the " REC " symbol only & execute the memory function continuously.

- c. To exit the memory record function, just press the " REC " button for 2 seconds at least. The display will revert to the current reading.

5. AUTO POWER OFF DISABLE

The instrument has " Auto Power Off " function in order to prolong battery life. The meter will shut off automatically if none of the buttons are pressed in approx. 10 min.

To disable this function, Select the memory record function during the measurement by pressing the " REC. Button " (3-4, Fig. 1).

6. RS232 PC SERIAL INTERFACE

The instrument has RS232 PC serial interface via a 3.5 mm terminal (3–7, Fig. 1).

The data output is a 16 digit stream which can be utilized for user's specific application.

A RS232 lead with the following connection will be required to link the instrument with the PC serial port.

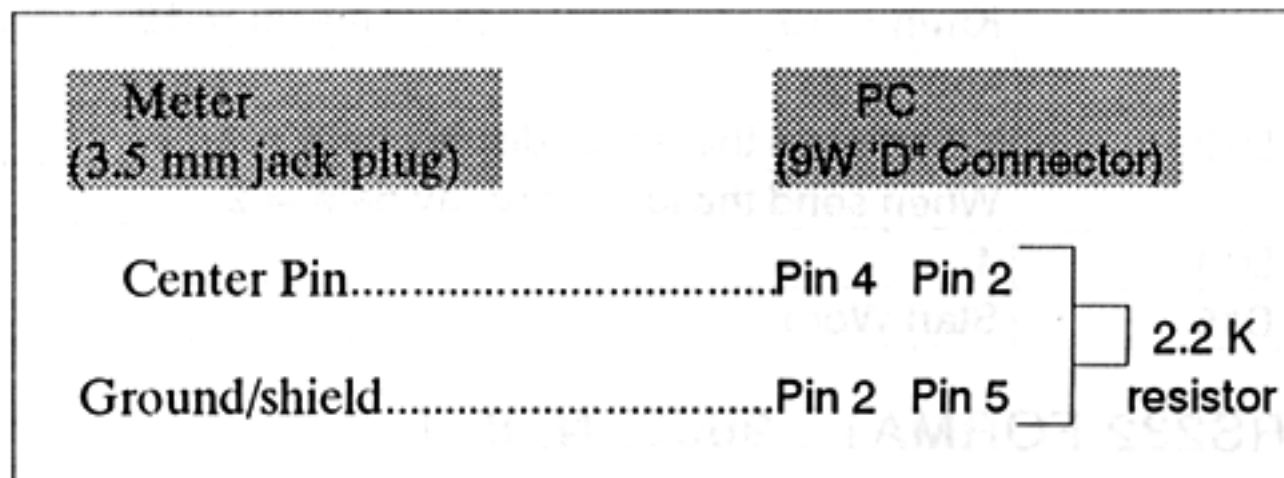

The 16 digits data stream will be displayed in the following format :

D15 D14 D13 D12 D11 D10 D9 D8 D7 D6 D5 D4 D3 D2 D1 D0

Each digit indicates the following status :

D0	End Word		
D1 & D8	Display reading, D1 = LSD, D8 = MSD <i>For example :</i> <i>If the display reading is 1234, then D8 to D1 is : 00001234</i>		
D9	Decimal Point(DP), position from right to the left 0 = No DP, 1 = 1 DP, 2 = 2 DP, 3 = 3 DP		
D10	Polarity 0 = Positive 1 = Negative		
D11 & D12	Annunciator for Display		
	°C = 01	°F = 02	m/s = 08
	Km/h = 10	ft/min = 11	mile/h = 12
	knot = 09		
D13	When send the upper display data = 1		
	When send the lower display data = 2		
D14	4		
D15	Start Word		

RS232 FORMAT : 9600, N, 8, 1

7. BATTERY REPLACEMENT

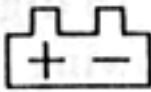
- 1) When the left corner of LCD display show "  ", it is necessary to replace the battery. However, in-spec. measurement may still be made for several hours after low battery indicator appears.
- 2) Slide the " Battery Cover " (3-9, Fig. 1) away from the instrument and remove the battery.
- 3) Replace with 9V battery (Alkaline or Heavy duty type) and reinstate the cover.
- 4) Make sure the battery cover is secured after changing the battery.