

Turbidity Sensor *OUS 31 / OUS 31-W*

**Process and immersion sensor for
drinking water and service water
based on the 90° scattered light method**

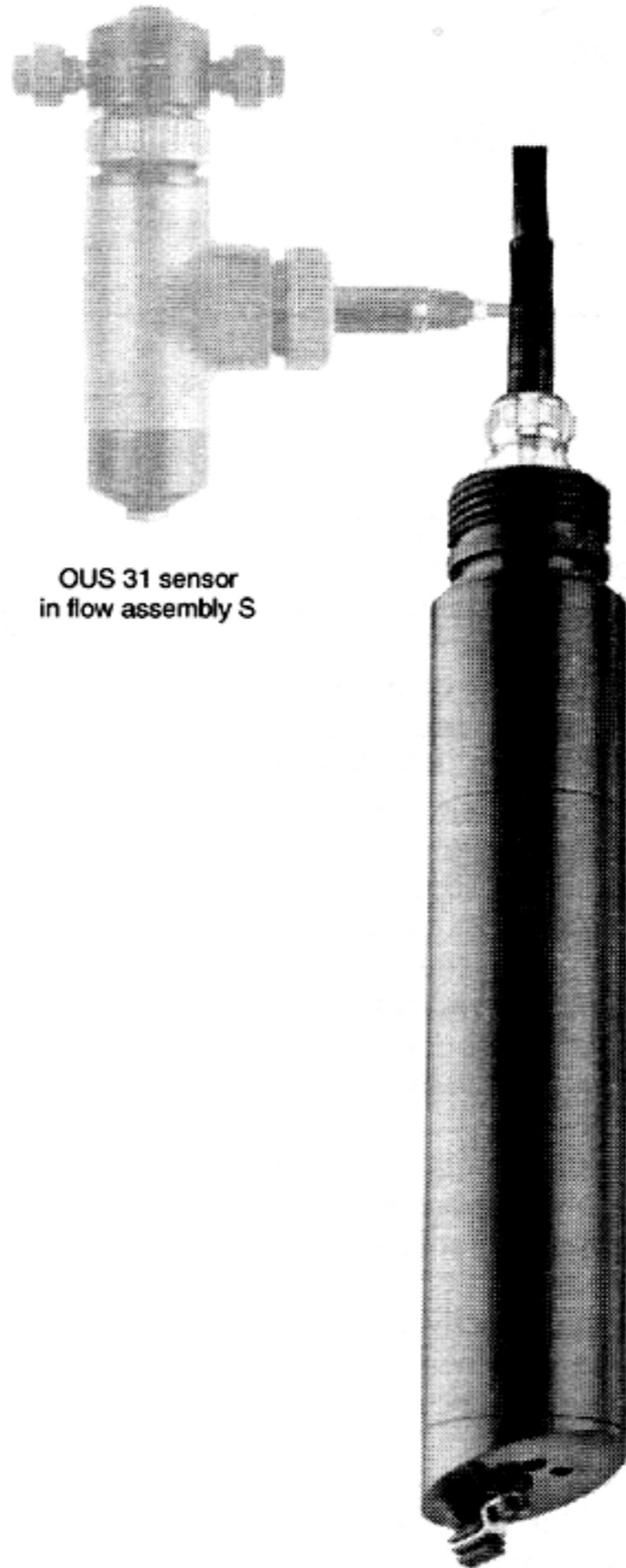

OUS 31 sensor
in flow assembly S

OUS 31-W sensor

Areas of application

Turbidity measurement is indispensable as a parameter for determining water quality and as a regulating variable for operation in the following areas:

- All phases of drinking water processing
- Coagulation and flocculation
- Filter rupture monitoring
- Filter backwash
- Control of clear rinsing cycles
- Monitoring of phase separation processes
- Boiler feed water
- Monitoring of cooling water
- Monitoring of surface waters
- Outlet control of sewage treatment plants
- Monitoring of industrial service water discharge
- Recycling of industrial service water

Benefits at a glance

- Available as a drinking water sensor for every installation with wall distance greater than 10 cm
- Commissioning without formazine factory calibration ("plug and play")
- Measurement according to DIN / ISO
- Flow assembly option available for gas bubble removal
- Measurement under pressure to avoid degassing
- For direct installation in water pipes, the backscatter signal can be adapted to suit the installation
- Wiper unit can be retrofitted
- Self-monitoring and plausibility check
- Integrated temperature measurement
- Inclined flat sensor surface uses medium flow to increase self-cleaning effect and repels water bubbles
- Sapphire measuring window
- Permissible distance between sensor and transmitter up to 200 m

Measuring system

A measuring system consists of:

- OUS 31 turbidity sensor
- OUM 223 transmitter (panel-mounted / field version)

Examples of complete measuring systems

left:
OUS 31 in
flow assembly

right:
OUS 31 in
immersion assembly

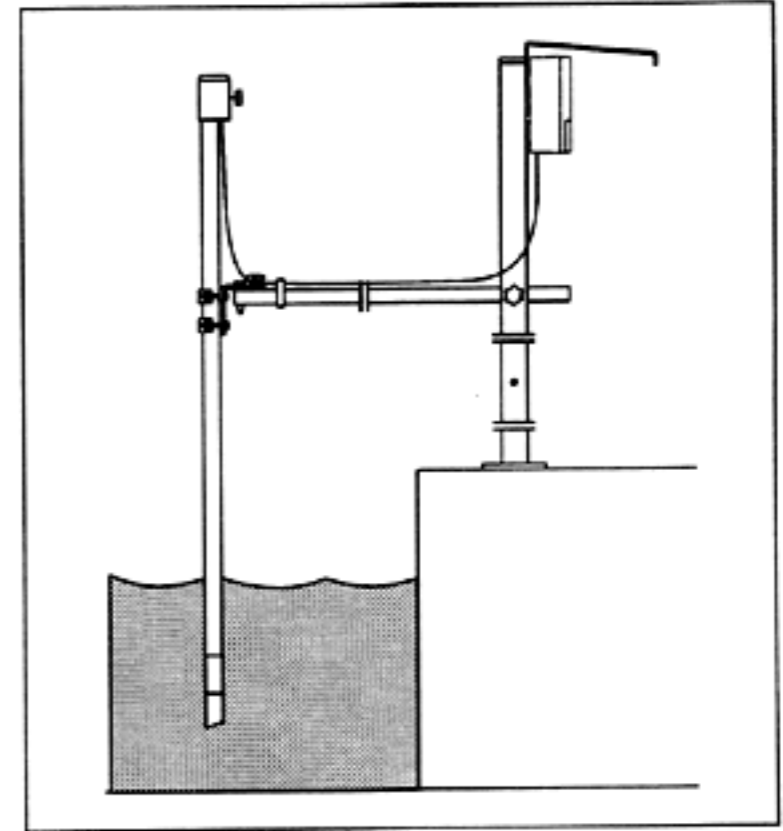
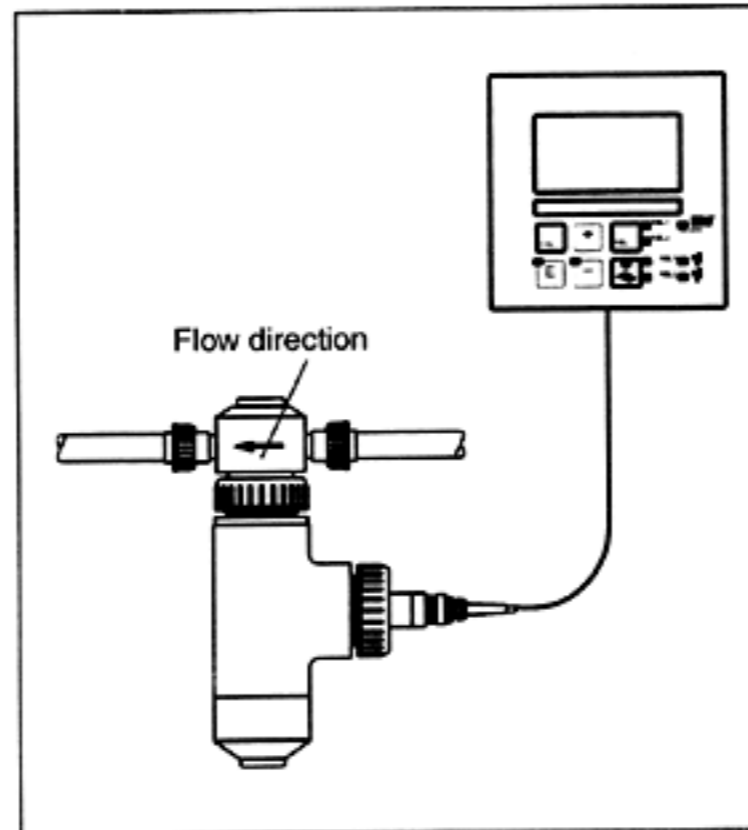

Functional principle

The 90° scattered light method with a measuring frequency in the near-infrared range of light (880 nm) according to ISO 7027 / EN 27027 guarantees a measurement of the turbidity value under standardised, comparable conditions.

The excitation radiation of an infrared transmitter strikes the medium at a defined angle of beam. The different refractive indices of the entrance window and the measuring medium (water) are taken into account. Particles in the medium generate a scattered radiation which strikes the scattered light receiver at a defined angle. The measurement in the medium is constantly adjusted with the values of a reference receiver.

Digital filter functions with an excellent interference signal suppression and sensor self-monitoring ensure additional measurement reliability.

In addition to the turbidity signal, a temperature measurement signal is detected and transmitted.

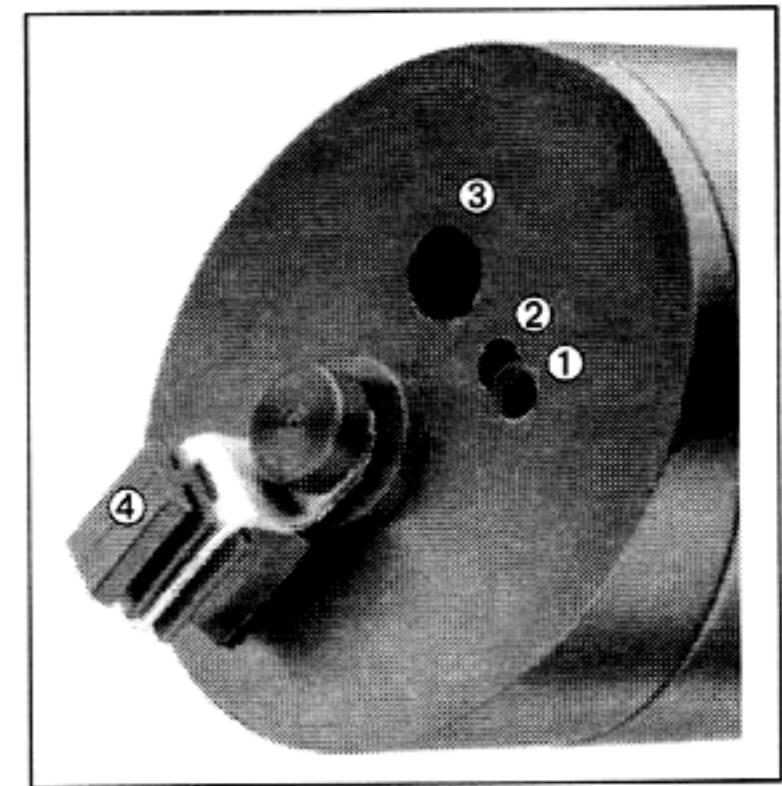

- ① LED
- ② photodiode
- ③ photodiode
- ④ wiper (optional)

Calibration

Every sensor in the "FNU field of application" is carefully factory-calibrated using standard procedures. Other OUS-tomer- and substance-specific calibrations can also be stored. Depending on the different precise requirements in service or drinking water, special assemblies with the integrated calibration values are provided.

For service water measurements, standard specifications are usually sufficient. However, installing the sensor in a pipe or very close to a wall can cause backscatter resulting in a higher signal. To compensate for this, an installation adjustment must be performed.

Notes on installation and application

Dependence of the measurement on the wall or floor distance

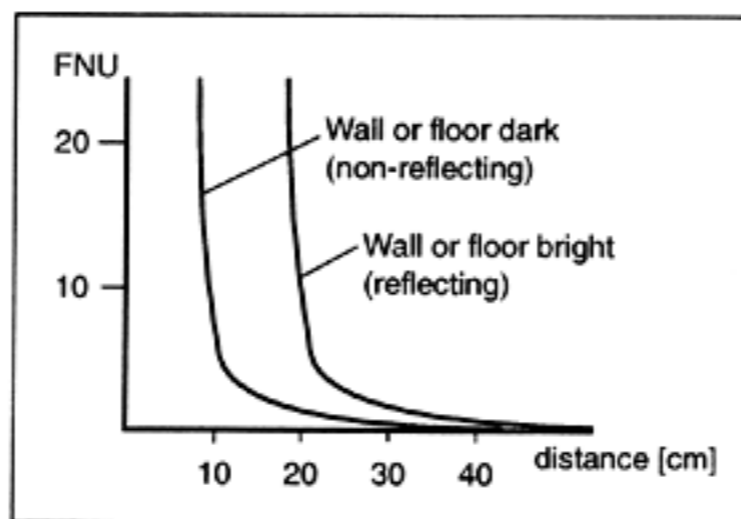

Wall distance

The effective wall or floor distance can be optimised by aligning with the flat sensor side. The opposite figure shows the influence of this distance on the measurement with bright or dark shading of wall or floor. As a rule, the OUS 31 sensor should be immersed at least 4 cm into the medium to be measured.

Self-cleaning by flow against the inclined sensor surface

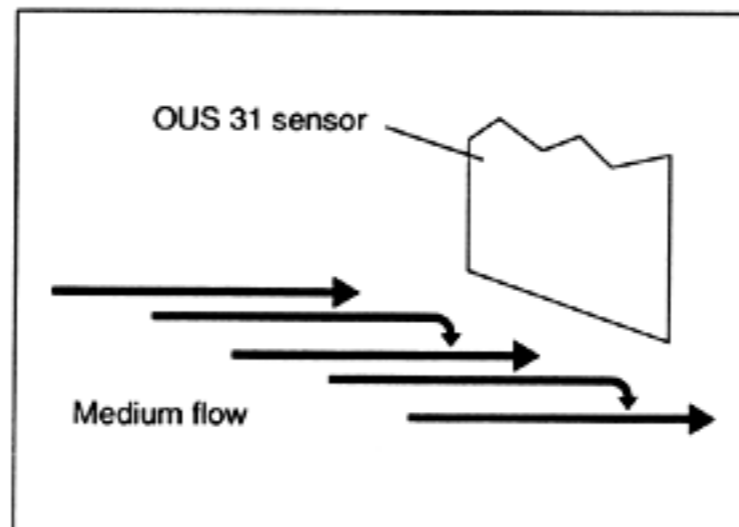

Self-cleaning

Optimum self-cleaning and sufficient wall distance (e.g. in narrow channels) are achieved by turning the inclined sensor surface into the flow direction. Some time after initial operation, the sensor should be checked for dirt. To clean it, wipe with a soft cloth. The most favourable sensor position should be maintained. Should self-cleaning not be sufficient, then we recommend the wiper sensor OUS 31-W or the spray cleaner OUR 4 – especially for media which tend to deposit sludge films or crusts.

Installation in immersion assemblies

Assembly holder OYH 101

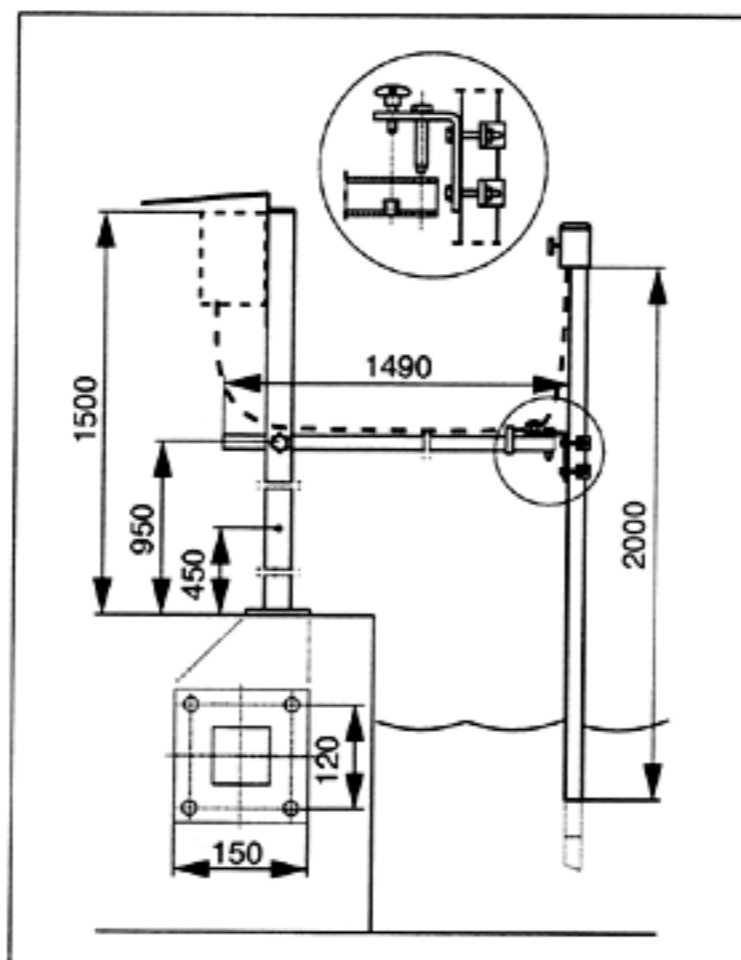

Note

When installing OUS 31 in an immersion assembly, such as OYA 611 with a pendulum frame, please note that sufficient wall distance must be maintained during the measuring process. The assembly should be installed where a minimum wall distance of 15 cm is guaranteed even with varying medium levels or changing flow conditions. Installation in a suspension assembly with chain must therefore be avoided.

Mounting

- Remove cover from holding tube.
- Pull connection cable through holding tube without twisting it; screw in sensor and turn to the stop.

Note:

First undo twists in cable by reverse twisting.

- Put on cover.
- Secure sensor cable to transverse pipe and connect it to the instrument, or if used, to the junction box.

OUS 31 sensor installed in OYA 611 assembly with pendulum frame

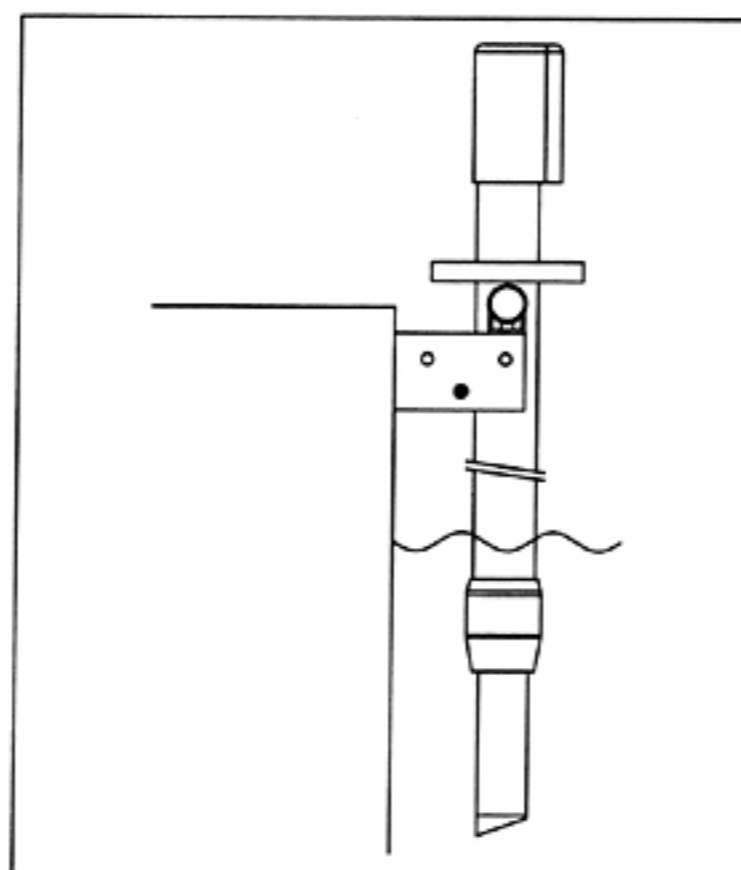

Pipe installation

Orientation and positions of OUS 31 with OUA 120-A/B adapter or OUA 461 retractable assembly

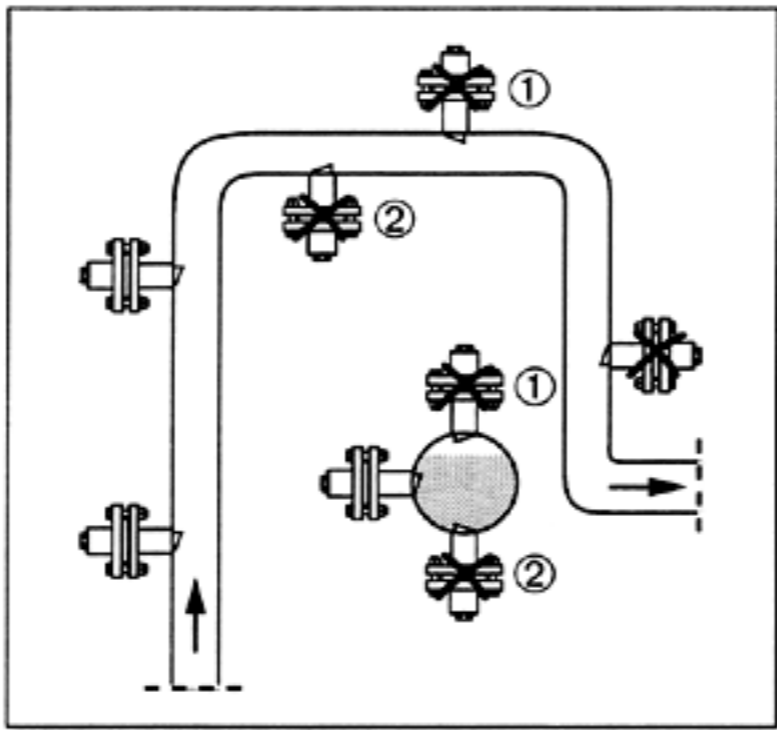

Notes

- The pipe diameter must be at least DN 100 when shiny materials (e.g. stainless steel) are used.
- Install the sensor in places with uniform flow conditions. Do not install it in places where air may collect, where foam bubbles are likely to form (①) or where suspended solids may settle (②).
- Install the sensor surface against the medium flow.

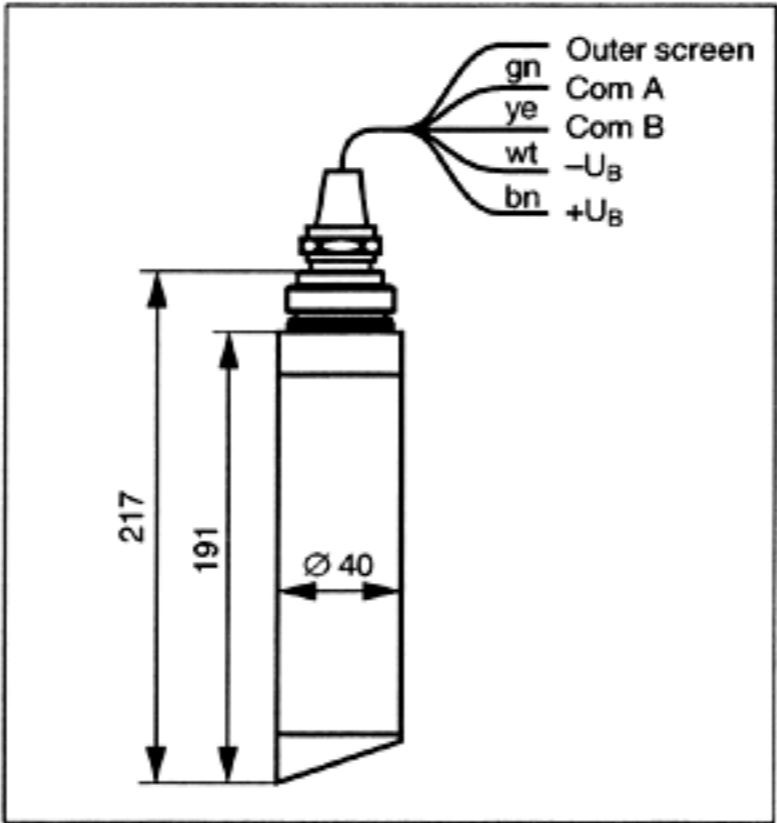

OUS 31 sensor

Mounting

- Lead connection cable through sleeve and hexagon coupling without twisting it.
- Insert sensor body into the sleeve so that the O-ring adjoins under the G 1" screw thread in the sleeve. Note marking pin and marking hole on the sleeve.
- Install OUS 31 into the adapter in such a way that the acute-angled edge of the sensor lies opposite to the marking hole and points away from it. The marking hole renders the sensor orientation clearly identifiable.

left:
OUA 120-B adapter with welding neck DN 50 / ANSI 2" (accessory) and lap joint flange DN 50 / ANSI 2" (to be provided by OUSustomer)

right:
Process connection adapter for pipe diameter greater than 80 mm

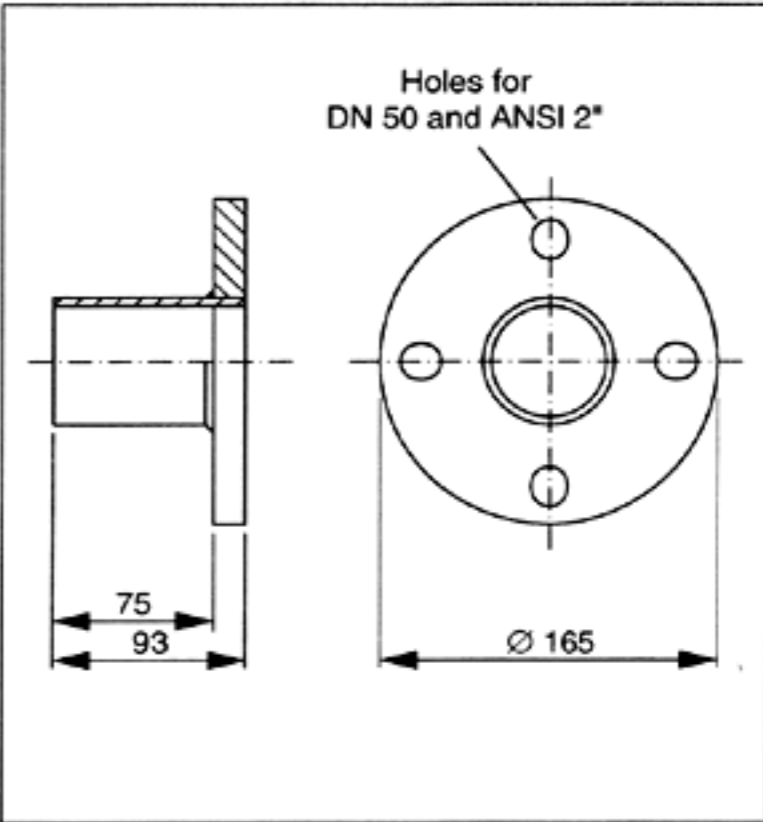
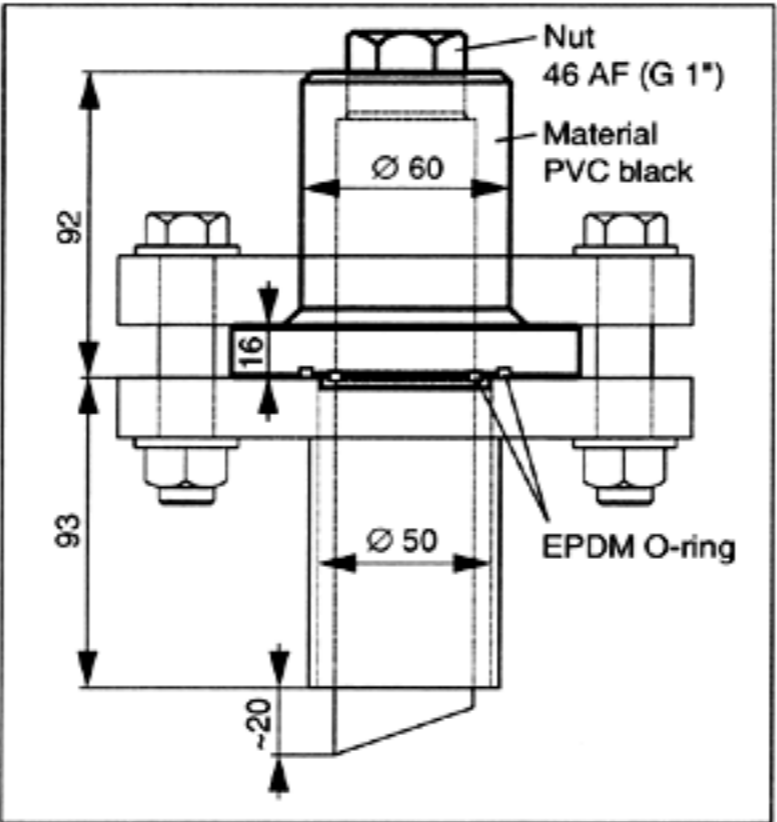

Welding neck DN 50 / ANSI 2"	
Material	Order no.
Stainless steel 1.4571 (SS 316Ti)	50080249
Polyvinyl chloride PVC	50080250
Polypropylene PP	50080251

Pipe installation (continued)

Dimensions of
OUA 461 assembly
1 Process connection
DIN Flange DN 50
or ANSI 2"
2 Process connection
adapter
(accessory, see p. 4)

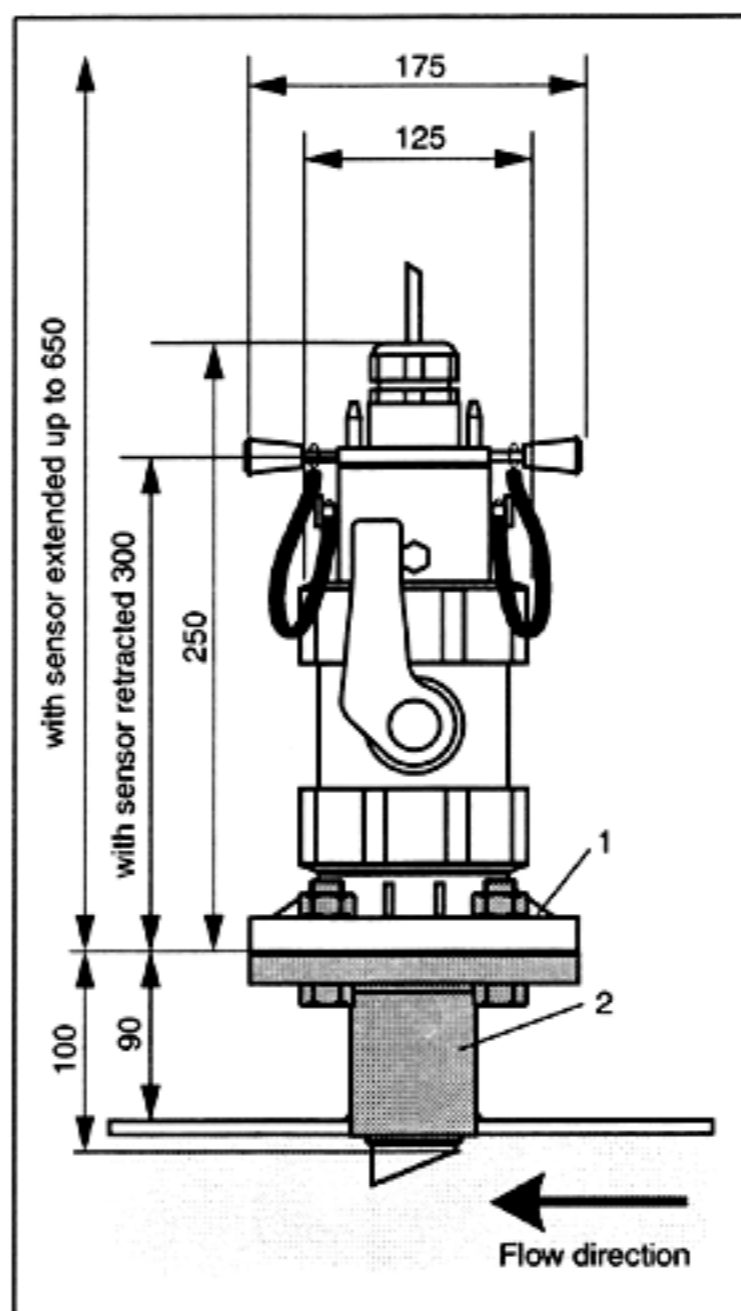

Installation in flow assemblies

Notes on installation

- The medium should, if possible, flow into the assembly from below. If the flow assembly must be installed in a horizontal instead of a vertical position, then install the sensor in the 3 o'clock or 9 o'clock position. This helps avoid air pockets.
- Installing the sensor parallel to the medium flow is necessary:
 - for turbidities < 5 FNU to minimise wall reflection effects.
 - Also carry out installation adjustment! – in conjunction with the spray head OUR 3.
- Installing the sensor against the medium flow is used to increase self-cleaning effects:
 - in heavily soiled media with turbidities > 15 FNU, where wall reflections can in any case be neglected due to the high absorption rate.

Sensor orientation parallel to the medium flow

The sensor is inserted into the union nut. Loosely tighten the hexagon coupling on the G 1" thread of the sensor. When the sensor is inserted with the sleeve on, the fitting hole on the upper edge of the assembly accommodates the locking pin. Position the sensor by turning it in such a way that the sharp edge formed by inclined sensor surface and sensor cylinder lies opposite the marking pin and points away from it. The spray-head connection in the T-section of the CUA 250 is now located over the sensor surface.

Sensor orientation against the medium flow

Position the sensor by turning it until the sharp edge formed by inclined sensor surface and sensor cylinder lies turned by 90° opposite the marking pin and points in the flow direction of the medium. Hand-tighten the hexagon nut.

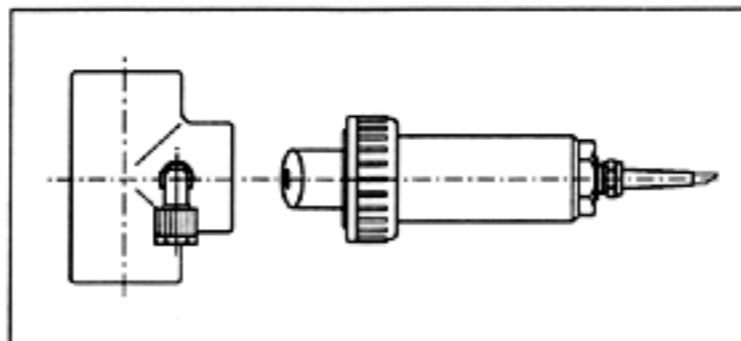

Installed parallel to
the medium flow

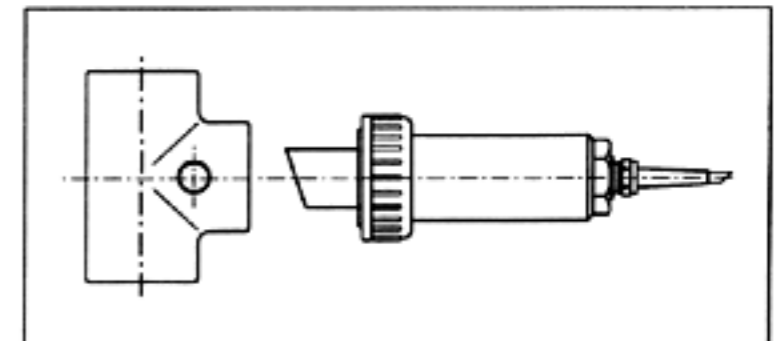

Installed against
the medium flow

Installation in flow assemblies (continued)

OUA 250-A, OUA 250-B

- Lead connection cable through union nut, sleeve and hexagon coupling without twisting it.
- Insert sensor body into the sleeve so that the O-ring adjoins under the G 1" screw thread in the sleeve.
Note locking pin and marking hole on the sleeve.

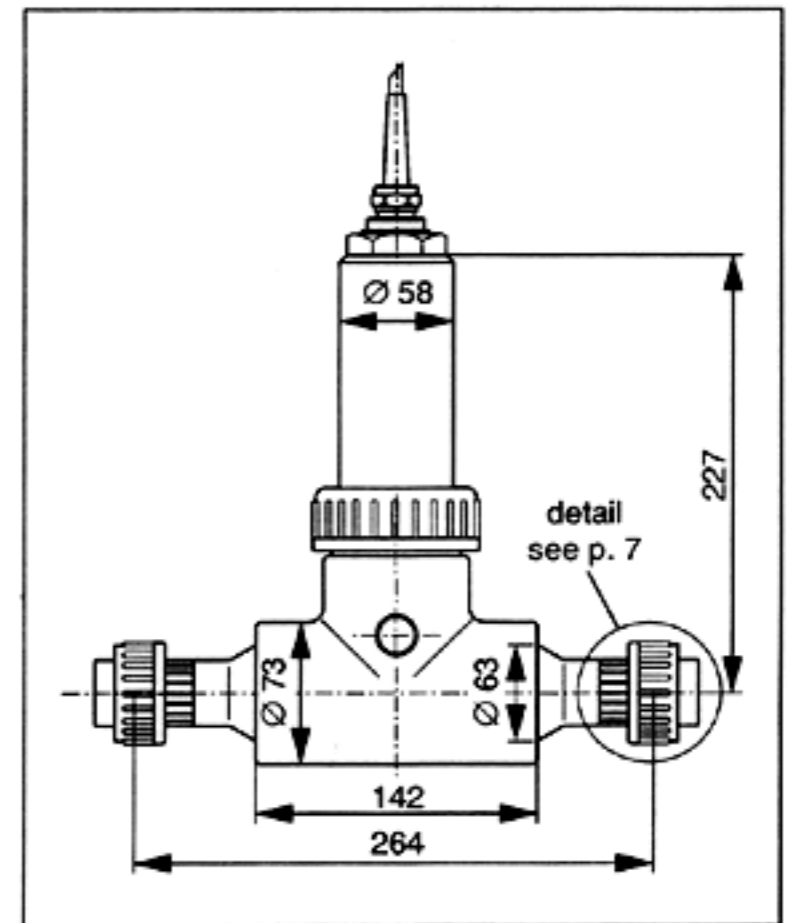

Dimensions
OUA 250-A/-B

Turbidity sensor with wiper cleaning

The OUS 31/41-W sensors are both equipped with a screen wiper. The cleaning times and intervals are entered into the OUM 223 transmitter. For optimum cleaning, wiper timing is adjustable.

Checking the rest position

- Pull the sensor from the assembly.
- Moisten the sensor surface.
- Set type of cleaning and cleaning times on the transmitter and start the wiping cycle.
- Check the wiper movement (cycle) on the sensor. The wiper must reach the rest position (see figure).



Caution:

Do not move the wiper arm by hand!



Note:

If the wiper comes to rest over the measuring windows, then measuring errors will result.

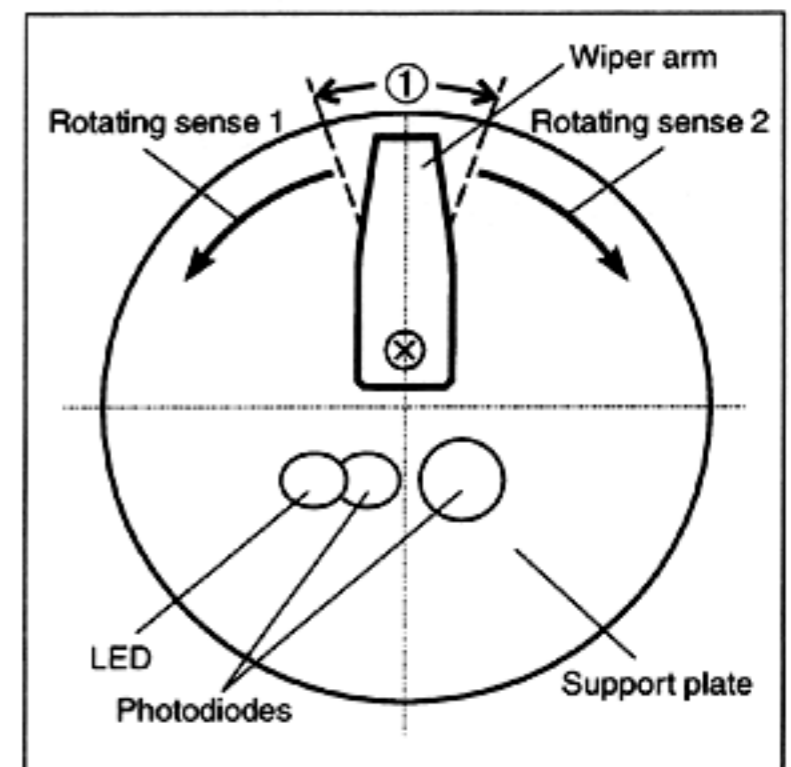

① Rest position of the wiper arm
Tolerance range: $\pm 20^\circ$

Installation in drinking water assemblies with special calibration

Due to the factory calibration (in the FNU measuring range), the measuring line can be put into operation at once. No initial calibration is necessary.

Conventional turbidity measurements are carried out in an unpressurised sample. When the pressure is relieved from the sample, ultrafine gas bubbles are produced which distort the true turbidity value. The assemblies provided for the OUS 31 permit pressurised measurement without modification providing several options for eliminating interfering gas bubbles:

- A bypass measurement is performed in the pressurised state, or pressure is not released until after measurement.
- If measurement in the unpressurised state is required, the gas bubbles can be removed by mechanical wiper cleaning. Wiper movement and timing can be programmed to obtain optimum results.
- The flow assembly with an integrated gas bubble trap reliably eliminates any incoming gas bubbles. Most of the bubbles flow directly to the assembly outlet in the upper half of the separated inlet. The other half of the incoming medium sample flows to a ring-shaped channel via the centre pipe where the remaining gas bubbles rise and exit the measuring chamber through holes in the outlet located in the centre of the assembly. Bubble-free water is pushed down into the measuring chamber. This also ensures high flow rates, resulting in short response times. Under normal conditions, this setup also helps avoid deposition.

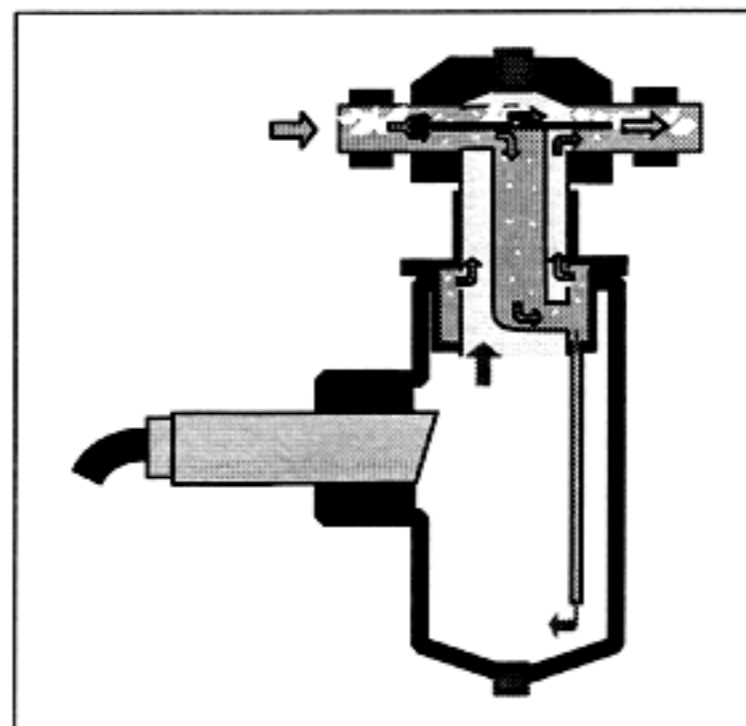

Integrated gas bubble elimination

Flow assembly E for media free of gas bubbles

- Arrange the inlet and outlet pipes vertically, with flow direction from bottom to top.
- Glue inlet and outlet pipes with a nominal diameter of DN 20 (25 mm outside diameter) into the PVC adhesive couplings.
- If required, mount wall support.

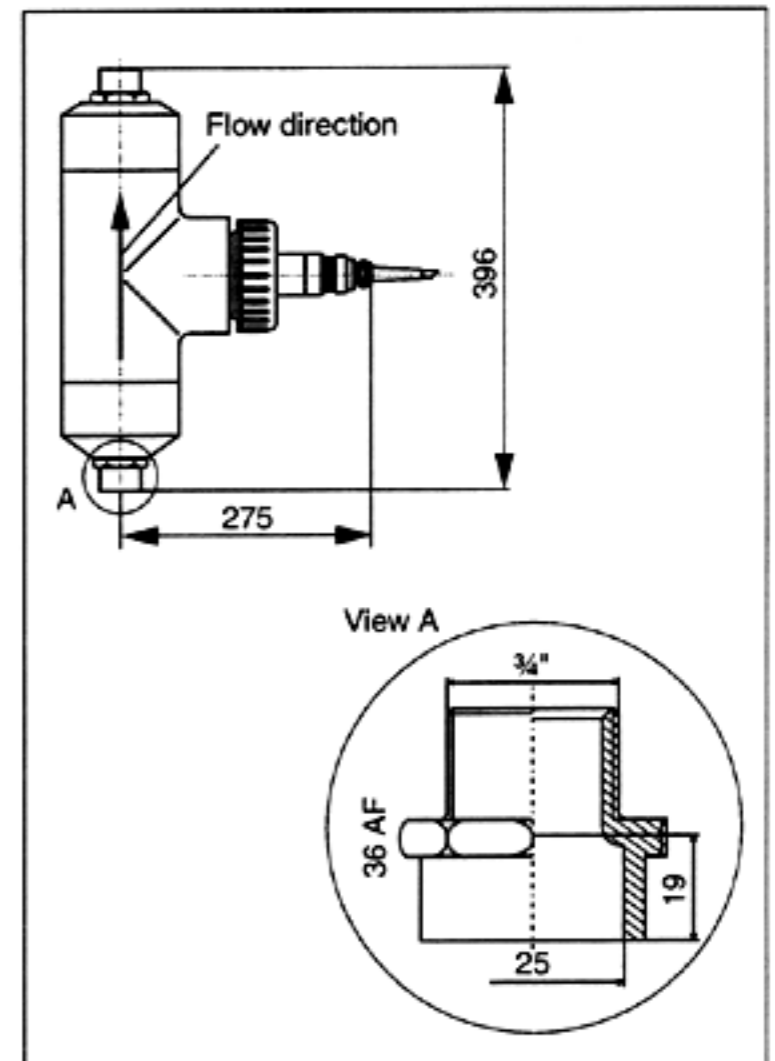

Flow assembly E

Flow assembly S with integrated gas bubble elimination

- Arrange inlet and outlet pipes horizontally, with flow direction according to arrow.
- Glue inlet and outlet pipes with a nominal diameter of DN 20 (25 mm outside diameter) into the PVC adhesive couplings.
- If required, mount wall support.
- Minimum flow rate 50 l/h.

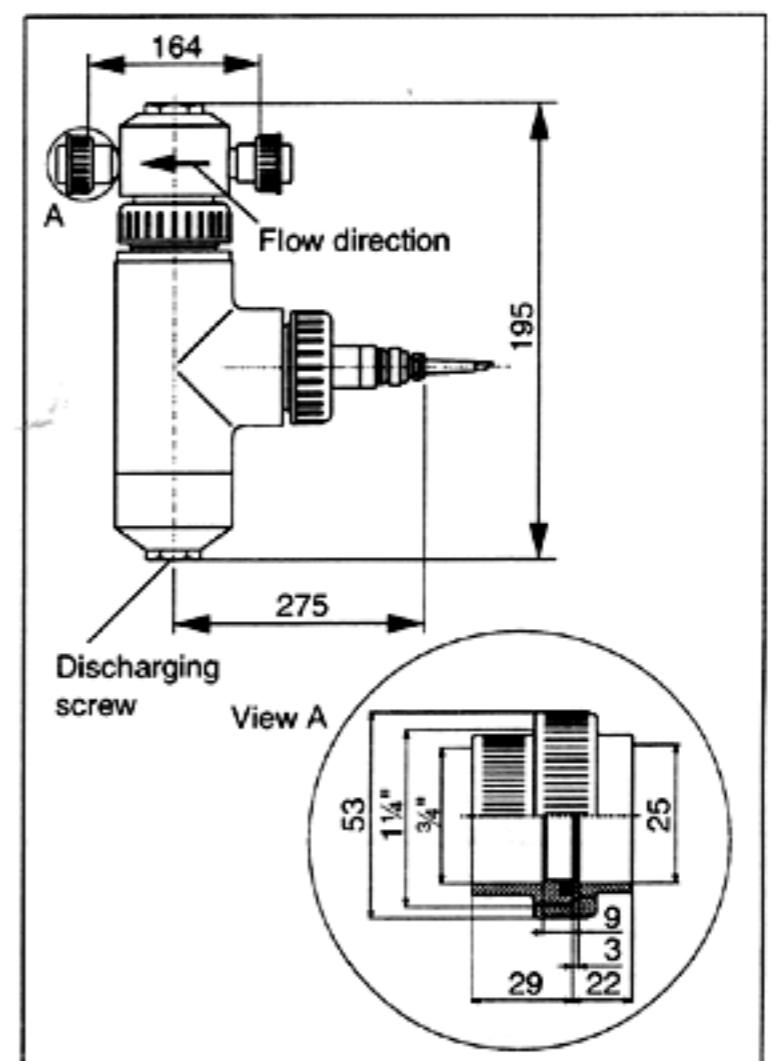

Flow assembly S

Technical data

Measuring principle	nephelometric 90° NIR scattered light according to EN 27027
Measuring ranges	0.000 ... 9999 FNU, 0.00 ... 3000 ppm, 0.0 ... 3.0 g/l, 0.0 ... 200.0%
Wavelength	880 nm
Optical reference compensation	by reference photodiodes
Factory calibration	formazine standard and SiO ₂
Temperature / pressure	25 °C / 6 bar ... 50 °C / 1 bar
Connecting cable	4-core with terminal bushes
Max. cable length	200 m
Temperature sensor	NTC
Nominal operating range	-5 ... +50 °C
Storage temperature range	-20 ... +60 °C
Ingress protection	IP 68

Materials

Sensor support plate, shaft, cable	PVC
Optical windows	sapphire
Flow assemblies	PVC

How to order

Turbidity sensor OUS 31	
<p>Sensor A Sensor in standard version W Sensor with integrated wiper</p>	
<p>Cable length 2 Connecting cable 7 m 4 Connecting cable 15 m 9 Connecting cable according to OUSustomer specifications</p>	
<p>Assembly A Without assembly E Assembly for media free of gas bubbles S Assembly with integrated gas bubble elimination</p>	
<p>↓ ↓ ↓</p> <p>OUS 31- [] [] []</p>	<p>complete order code</p>

