

Vantage Series 4000 Strap On Sensor Installation- Zee Shot <14 inch

The following is an instruction on installing the strap on sensor for the Vantage Series 4000. There are two styles of strap on sensors. One is referred to as Small Strap On sensor (used on pipe sizes 1”-8”) the other is the Large Strap On sensor (used on pipe sizes 4”-120”). The Zee Shot sensor rails will accommodate both the Small and Large sensors so the mounting configurations will be the same for either sensor. It is important to note, however, that the electronics unit will need to be programmed for the specific sensor used.

Where do I place my sensors in relation to upstream and downstream conditions?

The ultrasonic transit time flow meter accuracies are based upon well developed velocity profiles. Upstream disturbances such as pumps or tees and elbows will effect the velocity profile. Below is a recommended straight runs to assure meter accuracies.

| Device | Upstream from meter(in pipe diameters) | Downstream from meter(in pipe diameters) |
|-----------------------|--|--|
| Tees & Elbows | 10-15 | 2-3 |
| Reducers | 10 | 2-3 |
| Increasers | 20 | 2-3 |
| Valves (fully opened) | 10-15 | 2-3 |
| Valves (modulating) | 20-25 | 2-3 |
| Pumps | 20-25 | 2-3 |

In vertical runs, the flow should always be flowing up and never down.

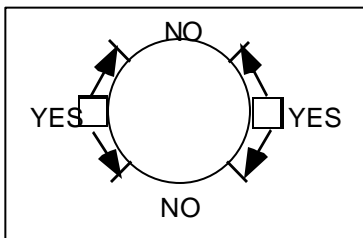

The sensor/sensor holders should always be placed on the side of the pipe as Shown on the left and never on the top or the bottom of the pipe.

Note:
Cast or Ductile Pipe

Sand pipe to a smooth surface under sensor face

1

Note:
Asbestos Cement Pipe

Place coat of shellac on pipe surface under sensor face

2

Zee Shot <14 Inch

(Top View)

3

Place Long Speedrail #1 On Pipe

SPEEDRAIL #1

4

Attach chains to hook

5

Rotate Speedrail to center of pipe

LEVEL

6

Use level on side of Speedrail to locate center pipe position



Finger tighten chains with wingnuts



Place bead of silicone grease on face of each sensor



Place Edge of Sensor #1 at Zero on Ruler

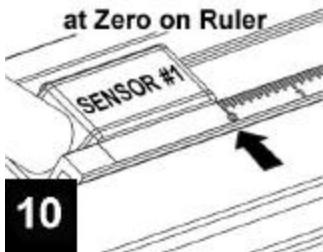

Slide clamp over center of Sensor

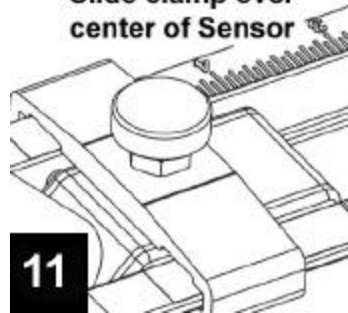

Secure sensor with thumbscrew (fingertight only)

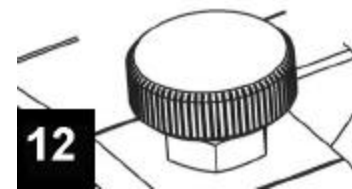

SPEEDRAIL #2

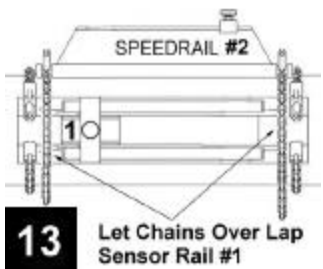

Attach chains to hook



Rotate Speedrail to center of pipe

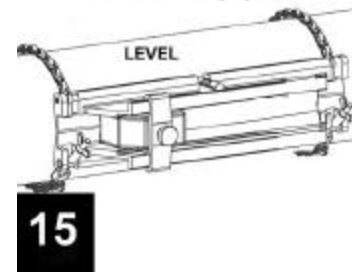

Use level on side of Speedrail to locate center pipe position



Finger tighten chains with wingnuts



Place bead of silicone grease on face of each sensor



Sensor Separation

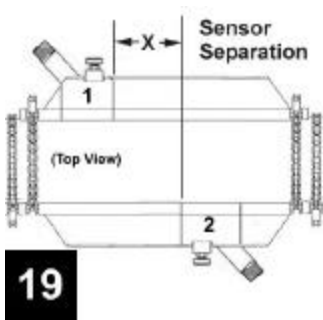

Slide clamp over center of Sensor

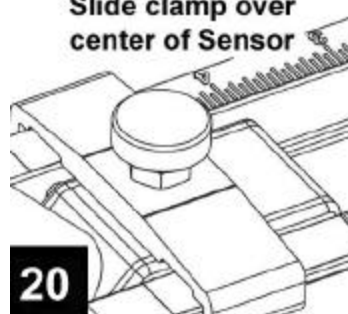

Secure sensor with thumbscrew (fingertight only)

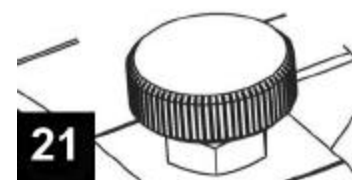

Attach conduit to
each sensor

22

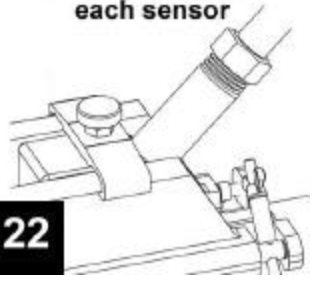

Zee Shot <14 Inch

(Top View)

