

VANTAGE SERIES 4000



ULTRASONIC TRANSIT-TIME FLOWMETERS

VANTAGE[®] 4000

*Engineered for Accuracy
and Simple Installation*



Eastech Badger Introduces the New Vantage® 4000 Transit-Time Flowmeter

Model 4400	Model 4600
<ul style="list-style-type: none"> ▶ One 4-20 mA Output ▶ One SPDT Relay ▶ RS232 Serial Port (Modbus RTU Protocol) 	<ul style="list-style-type: none"> ▶ Two 4-20 mA Outputs ▶ Three SPDT Relays ▶ RS232 Serial Port (Modbus RTU Protocol) ▶ RS485 Serial Port (Modbus RTU Protocol) ▶ Internal Datalogger 

A Palm® PDA is provided at no charge with each purchase order for the Vantage 4000 Series.

Factory Pre-programmed

The engineers at Eastech Badger realized that for a new product to be successful, it must be simple to install and quickly made operational. In order to accomplish this goal,

PROGRAMMING VALIDATION	
PIPE SIZE:	16 IN.
PIPE MATERIAL:	DUCTILE
FLOW MEDIA:	WATER
MAX PRESSURE:	100 PSI
FLOW DIRECTION:	UNI-DIR

every Vantage 4000 is shipped to the field factory pre-programmed to the conditions set forth by the customer. Pre-programming specifications are

electronically confirmed on the display of the transmitter. If changes to the meter's factory pre-programming is required, re-programming can simply be accomplished on the meter keypad or through the **Auto-Programming** feature. This feature allows plant personnel to re-program the Vantage 4000 by simply downloading the revised flow data from a PC or laptop to the Palm® PDA supplied with the meter. The Palm will re-program the unit to the new specifications.

Accuracy & Reliability

The Vantage® 4000 employs the latest DSP microprocessor technology. An exclusive signal processing technique combines correlation and FFT detection methods in order to ensure the highest degree of accuracy and reliability possible.

- Rangeability: 40 to 0.1 ft/sec
- Turndown: 400:1
- Repeatability: 0.25%
- Accuracy: ±1% of actual flow



Transmitter



- ▶ Water & Wastewater
- ▶ Sewage Treatment
- ▶ Acids & Toxic Liquids
- ▶ Petroleum Products
- ▶ HVAC & Irrigation

Eastech Badger was the first company to utilize a phase shift detection system in the design of transit-time flowmeters. This technique greatly improves time difference detectability, which in turn, enhances accuracy and operating stability while substantially reducing the effects of noise.

Accuracy & Reliability

- Rangeability: 40 to 0.1 ft/sec
- Turndown: 400:1
- Repeatability: 0.25%
- Accuracy: ±1% of actual flow

The electronic design of the Vantage 4000 utilizes the latest microprocessor technology and operates in conjunction with a DSP floating point coprocessor. An exclusive signal processing technique combines correlation and FFT detection methods to ensure the highest degree of accuracy and reliability.



Flash memory is employed for logging of flow data. Up to 8 channels can be logged—including flow, velocity and totals for one or multiple sensors. The storage capacity for a single channel logging at 5 minute intervals is 113 days. In addition, graphs may be visually displayed in pre-programmed time intervals. Daily summary allows viewing of the previous eight days. This includes times, dates, averages, minimums, maximums and totals. Plant operating personnel also have the ability to simply download logger data through the use of a standard Palm® or laptop.

Programming

For fast and simple installation, each Vantage Series 4000 is pre-programmed at the factory for customer specific flow measurement applications.

If re-programming is required in the field, the **Auto-Programming** feature allows for the corrected flow data to simply be downloaded from a PC to the factory supplied Palm and then imported to the meter. Additionally, a self-prompting backlit display, with a menu-driven guide available in English, Spanish and German, allows for 15 minute programming of standard applications and 30 minute programming of in-depth data logging applications and auxiliary outputs.

Programming of the meter is accomplished through the 16 button keypad. The LCD display is a backlit 128 x 64 graphic module. A simple to use drill-down menu structure allows for quick programming and set-up of the meter. Most common pipe sizes and schedules are stored in memory for ease in programming a specific application. Non-volatile memory ensures that programming constants are not lost during disruption of power.

Model 4400	Model 4600
<ul style="list-style-type: none"> ▶ One 4-20 mA Output ▶ One SPDT Relay ▶ RS232 Serial Port (Modbus RTU Protocol) 	<ul style="list-style-type: none"> ▶ Two 4-20 mA Outputs ▶ Three SPDT Relays ▶ RS232 Serial Port (Modbus RTU Protocol) ▶ RS485 Serial Port (Modbus RTU Protocol) ▶ Internal Datalogger
	

Data Logging

The Vantage 4000 has a 256K Byte logger with storage intervals. The logger can be programmed for various time intervals. Up to 8 channels can be logged—including flow, velocity and totals for one or multiple sensors. The storage capacity for a single channel @ 5 minute intervals is 113 days. IEEE floating point storage is used.

Daily Averages

Flash memory is employed for logging of flow data. Data is retrieved by viewing the local display or downloaded via the serial port. Daily summaries allow viewing of the previous eight days. Included are times, dates, averages, minimums, maximums and totals.

Logger Graph

A graph may be visually displayed on the 4000. The graph will display the stored logger data in pre-programmed time intervals.

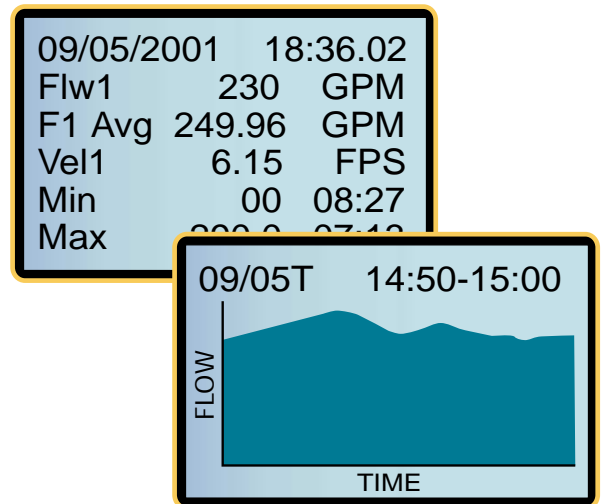

Data Retrieval

The Vantage 4000 is designed for reliable and accurate retrieval of data—either on-site or remotely. The unit is equipped, as standard, with an integrated data logger capable of storing large amounts of information for later analysis. Because of its multiple output capability, this information may simply be retrieved through the use of one of the following methods.

Palm / Laptop

The Eastech Badger data collection system allows plant operating personnel the ability to simply download logger data through the use of a standard Palm PDA or laptop. This information can then be transferred to a PC. Free operating software may be downloaded from the Eastech Badger website.

Modem

A modem can be installed within the enclosure of the 4000 for phone line or wireless transfer of data to a central location. Since the Vantage has two totally independent communications ports (RS-232 and RS-485), a single modem can provide data for multiple meters communicating serially through a field network such as Modbus.

Multiple Outputs

Two 4-20 mA	Isolated, 800 ohms maximum.
Three SPDT Relays	Available for alarm conditions.
RS232	With Modbus protocol. Flow control is CTS/RTS or none. DB-9 connection.
RS485	With Modbus protocol, isolated. The RS-232 & RS-485 can be set with different slave I.D.s.

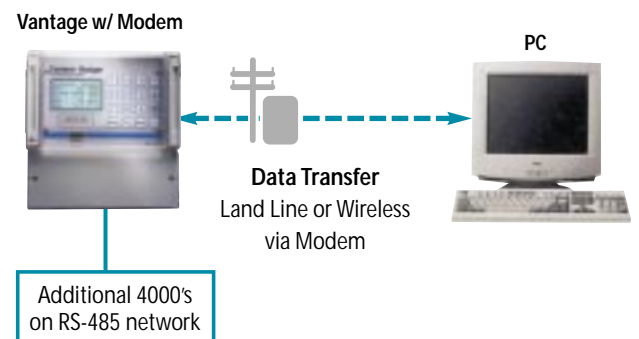
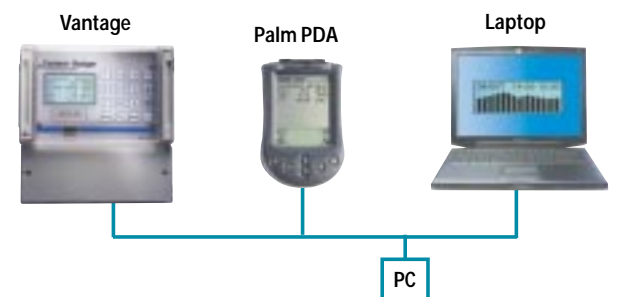

Acoustic Sensors



Eastech Badger offers a wide range of sensor options covering a multitude of applications. Simple “walk through” installation instructions are graphically displayed on the Palm® for local reference in the field

Externally Mounted Sensor

Externally mounted sensors are the preferred design when acoustic signals are capable of being transmitted through pipe or conduit. The sensors are fully potted, incorporating an FM approved explosionproof design for use in Class I & II, Division 1 hazardous areas or Division 2 nonincendive areas. Both sensors and mounting hardware are designed to resist corrosion, function when buried or submerged and operate over a wide temperature range of -30° to 150°F (-30° to 300°F optional). External sensors are suitable for placement on all metallic and plastic piping, with the exception of pit cast iron and layered fiberglass pipe.

Application: 1" and larger. Plastic, Metallic, Asbestos Cement and Ductile/Cast Pipe.

The externally mounted sensor is the preferred design when acoustic signals are capable of being transmitted through pipe or conduit.

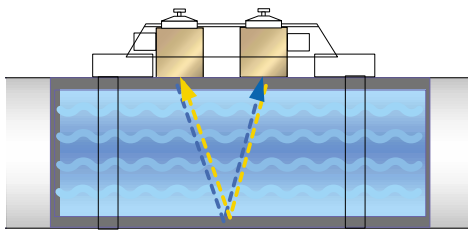

Externally mounted non-wetted sensors (V-Shot)

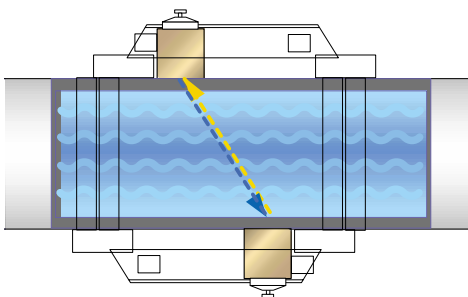

Externally mounted non-wetted sensors (Z-Shot)

SpeedRail™ Mounting



Since externally mounted sensors are the preferred design for transmitting signals through pipe or conduit, a new one piece **SpeedRail™** sensor mounting system was developed. Mounting of both sensors is quickly and accurately accomplished in two simple steps. Lock the self-aligning mounting rail to the pipe or conduit and load in the sensors.

Once the sensors are connected to the transmitter, the Vantage 4000 is ready to measure flow.

Instream Sensor

In open conduits over 12 inches in width or in large concrete pipes where the outside of the pipe is not accessible, the instream sensor is recommended for accurate fluid velocity measurement. The design of the sensor facilitates simple installation. Sensor configuration allows flush mounting against the sidewall. For accuracy and ease of installation, a unique internal hoop design is available with premounted instream sensors. This mounting arrangement makes installation fast and precise. Sensors are constructed of PVC and are fully potted. (SEE BULLETIN NO. EB401)

Application: Large diameter pipe and pipe or conduit not accessible from the outside.

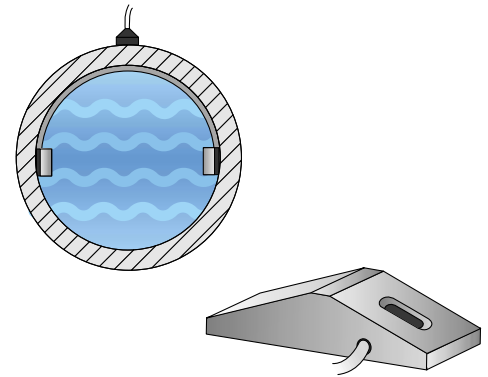

Windowed Sensor

Fabricated spool pieces are available in a windowed sensor design with a wide choice of end connections and materials of construction. Spool pieces are supplied with both sensors mounted and calibrated to the electronics. Windowed sensors transmit and receive ultrasonic pulses through an acoustic window which is in contact with the flow stream. The design allows sensor removal without de-watering of the line. The sensors and windows are constructed of Ultem® thermoplastic material and carry a temperature rating of 150°F and a pressure rating of 150 psi. (SEE BULLETIN NO. EB402)

Application: 3" to 48" with stainless or carbon steel construction and ANSI, AWWA and plain end connections.

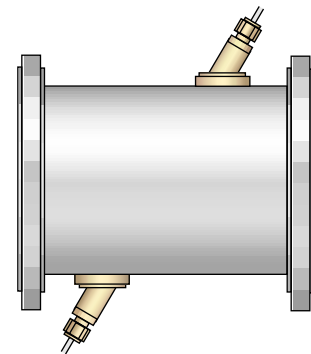

Wetted Sensor

"Hot Shot" sensors are utilized on piping or conduits that inhibit the transmission of acoustic energy. A standard concrete saddle tap is employed for penetration of the pipe wall. "Hot Shot" sensors are available for 6" and larger pipe. The sensor design allows for flush mounting within the conduit, thereby eliminating turbulence or the build-up of solids around the measuring point. Sensors are provided with an integral valve in order to allow sensor removal without shutting the process down. Constructed of PVC and fully potted, the sensors carry a pressure rating of 150 psi. (SEE BULLETIN NO. EB403)

Application: Concrete, Asbestos, Cement, Fiberglass Wrapped, Wood Stave, heavily corroded steel pipe and pipes with considerable calcium build-up.

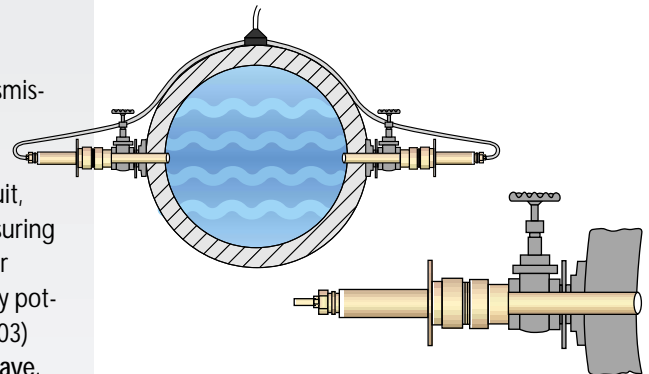

Multi-Path/Dual Pipe

For applications that do not have a sufficient straight upstream run so as to ensure a well developed velocity profile (thereby affecting the accuracy of single path sensor configurations), up to three sets of sensors can be configured in a Multi-Path arrangement.

The Vantage 4600 may be programmed for dual pipe operation. Two sets of sensors are individually mounted on separate piping runs. The 4600 measures the flow in each pipe, displaying the flow rate and totals. The totalizer can be configured to display individual totals, the sum total or the difference between the two flow rates. Two 4-20 mA output signals are provided. (SEE BULLETIN NO. EB404 & EB405)

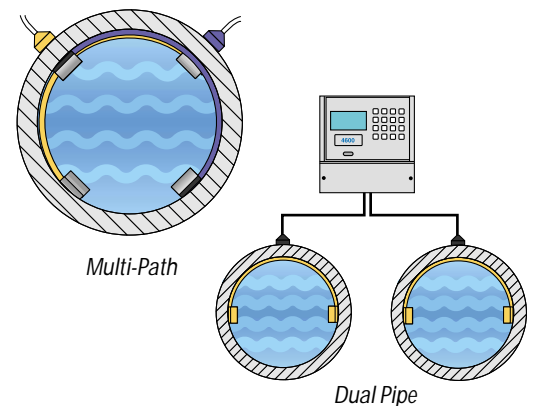

SPECIFICATIONS

PERFORMANCE (forward and reverse flow)

Linearity	± 0.5%
Repeatability	0.25%
Accuracy	±1% of actual flow
Rangeability	40 to 0.1 ft./sec.
Turndown	400 : 1
Power Supply	High immunity: Approvals CE, UL, CSA
Input Range	85 to 265 VAC
Input Freq. Range	47 to 440 Hz

SENSORS



Pipe Diameter	1" to 120" (above 120", consult factory)	
Temperature Rating	-30° to 150° F Optional to 300° F (Strap-on only)	
Sensor	Pressure Rating	Max. Cable Distance
Strap-on (1" - 120")	Not applicable	1000 ft.
Instream (12" - 120")	150 PSI	1000 ft.
Wetted (12" - 120")	150 PSI	1000 ft.
Windowed (3" - 48")	250 PSI	250 ft.
Materials of Construction		
Sensors:	Anod. Alum./Ultem®/PVC	
Strap-on hardware	Anod. Alum. (304 SS optional)	
Hot-shot Valve Body	Brass	
Sensor Cable	Triax Beldon 9222 (50 ft. std.)	

Hazardous Area Installations

All sensors (except windowed spool sensors) have been Factory Mutual approved for use in Class I & II, Division I, Groups A - G, hazardous areas, except in acetic atmospheres.

TRANSMITTER



3 Year Warranty

ENCLOSURE	
Standard	Nema, 4, 4X polycarbonate (9.25" x 8.87" x 5.38")
Optional	Nonincendive Class I & II, Grps. A - D, Div. 2 Explosionproof, Aluminum Class I, Grps. C & D, Class II, Grps. E, F, G, Div. 1 & 2
Accessories	Heater and thermostat, Door Lock/Modem
TEMPERATURE	
Standard	-4° to 158°F (-20 to 70°C)
With Heater	-40° to 158°F (-40 to 70°C)
OUTPUTS	
4-20 mA	Analog isolated into 800 ohms max, monitored to detect open circuits. RFI and gas discharge surge protection and two fuses.
Relay Alarms	SPDT relays (pluggable) 0.25A @ 120 VAC or 0.50A @ 24 VDC
RS-232 Serial Port	1200-38400 Baud, Modbus RTU protocol
RS-485 Serial Port	Optically isolated, Modbus RTU protocol
DC Power Out	12 VDC, 100mA maximum
DISPLAY	
Backlit LCD	128 x 64 Graphic Module
POWER	
Wattage	12
Voltage	80/240 VAC, 50/60 Hz / 12-28VDC @ 250 mA.
DATA LOGGING	
Non-volatile flash memory, storage of up to 32768 records.	

ORDERING GUIDE (Please specify pipe size, pipe material, flow media and flow direction)

Enclosure	Sensors	Extra Cable	Options	Data Retrieval
4400 Nema 4, 4x; General Purpose • One 4-20mA output • One SPDT Relay • RS-232 serial port 	External Strap-On (1" - 42" Dia. Pipe) AS1 External Strap-On (48" - 120" Dia. Pipe) AS2 External Strap-On (High Temp.: 300°F) AS3 Instream (12" - 120" Dia. Pipe) AS4 Wetted "Hot Shot" (12" - 120" Dia. Pipe) AS5 Windowed (3" - 48" Dia. Pipe) AS6 Dual Pipe/Multi-Path contact factory.	<p>Note: Each sensor is equipped with 50 feet of cable as standard.</p> <p style="text-align: center;">100 ft. B</p> <p style="text-align: center;">Above 100 ft. Please specify exact cable length. _____ ft.</p>	Factory Calibrated A (No Charge) Heater & Thermostat B Keylock C Splice Kit D Extra Relays (Model 4400) 2 Relays E 3 Relays F	Modem (phone line) M
4400N Same as 4400 except FM rated: Nonincendive: Cl. I & II, Grp. A-D, Div. 2				
4600 Nema 4, 4x; General Purpose • Two 4-20mA outputs • Three SPDT Relays • RS-232 serial port • RS-485 serial port 				
4600N Same as 4600 except FM rated: Nonincendive: Cl. I & II, Grp. A-D, Div. 2 For Div. 1 Explosionproof areas contact factory.				

*With each purchase order for Vantage 4000's, a Palm PDA is included at no charge.