



Badger Meter Europa

MoniSonic 4600/4700

Ultrasonic transit time flow meters

Description

The flow meters of the MoniSonic 4600/4700 series are transit time ultrasonic flow meters designed for accurate and reliable flow measurement of ultrasonic conductive fluids in pressure pipes from DN 13 to DN 6000. Measuring temperatures range from -40°C to +200°C. The flow meter can be programmed upon the front keypad.

The strap-on sensors can be installed on either horizontal or vertical pressure pipes. Condition for an accurate flow measurement is a well developed velocity profile which can be achieved by a full pipe with sufficient straight inlet and outlet pipe length (10xD / 5xD). The measuring accuracy is $\leq \pm 1,5\%$ of actual flow. The sonic velocity of the medium is measured permanently and corrected accordingly.



Thanks to high performance processors (32bit MPU), an extremely high measuring dynamic has been achieved. 256 measurements/sec. secure a complete flow velocity recording.

The flow meters have a two line, backlighted LCD display. Actual flow, totalizer and status are displayed. Selectable languages are German, English and French for model 4600, English for 2-path meter model 4700.

Measuring principle

The meters are operating according to the ultrasonic transit time method. Ultrasonic waves are transmitted and received diagonally across the flow stream. The flow velocity is calculated from the difference (Δt) of the transit times. Compared to a Doppler measurement, the transit time method is working more accurate and reliable.

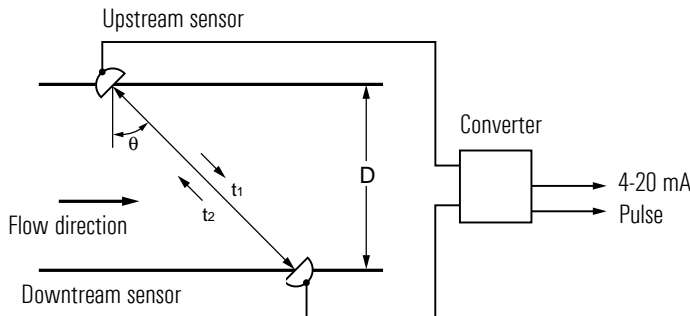

Applications

- Water & waste water
- Heating and cooling water

- Waste water treatment
- Hydrocarbons

- Acids & toxic liquids, detergents

MoniSonic 4600 / 4700-engl.doc 09/06

Technical data

Type	MoniSonic 4600	MoniSonic 4700
Measuring principle	Transit time 1-path	Transit time 1- or 2-path
Housing material	Aluminium	
Mounting	Wall- or pipe mounting	Wall mounting
Dimensions HxWxD	312 x 244 x 95 mm	420 x 240 x 134 mm
Protection class	IP 65	
Operating temperature range	-10°C to +60°C	-10°C to +50°C
Outputs	4-20 mA, max. load 1k Ω 2 x open collector, 30 VDC / 0,1 A RS232 (optional)	3 x 4-20 mA, max. load 1k Ω 6 x open collector, 30 VDC / 0,1 A BCD output (optional) RS232 or RS485 (distance 15 m up to 100 m)
Inputs	-----	
Display functions	actual Q and V, total for- and backward, alarms	
Display language	German, English, French	English
Supply voltage	100 to 240 VAC, 50/60 Hz or 20 to 30 VDC	100 to 120 VAC, 50/60 Hz or 200 to 240 VAC, 50/60 Hz
Programming	Via front keypad	
Data logger	-----	

Measurement accuracy

V	DN	MoniSonic 4600	MoniSonic 4700
0 – 2 m/s	13 – 50	0,03 m/s	-----
	50 – 300	0,02 m/s	
	300 – 6000	0,01 m/s	
2 – 32 m/s	13 – 50	$\pm 0,75$ to 1,5% of actual Q	-----
	50 – 300	$\pm 0,5$ to 1% according to act. Q	
	300 – 6000	$\pm 0,5$ to 1% according to act. Q	

Strap-on sensors

DN	Typ	MoniSonic 4600	MoniSonic 4700
13 – 100	FLD22	max. 100°C	-----
50 – 400	FLW12	max. 80°C, Ex-proof optional	
50 – 400	FLW32	-----	max. 200°C
50 – 400	FLD32	max. 200°C	-----
200 – 1200	FLW41	max. 80°C, Ex-proof optional	
200 – 6000	FLW51	max. 80°C, Ex-proof optional	

	MoniSonic 4600	MoniSonic 4700
Sensor material	Plastic, stainless steel, Aluminium	
Cable length	5 to 150 m	
Temperature range	-40°C to +200°C	
Protection class	IP67 / FLD22 and FLD32 IP52	IP67 (FLW3 IP52)

Dimensions

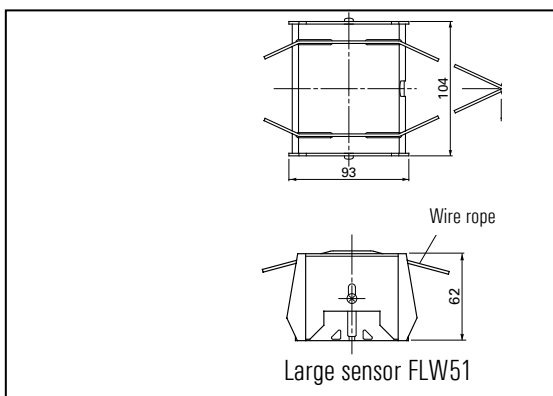
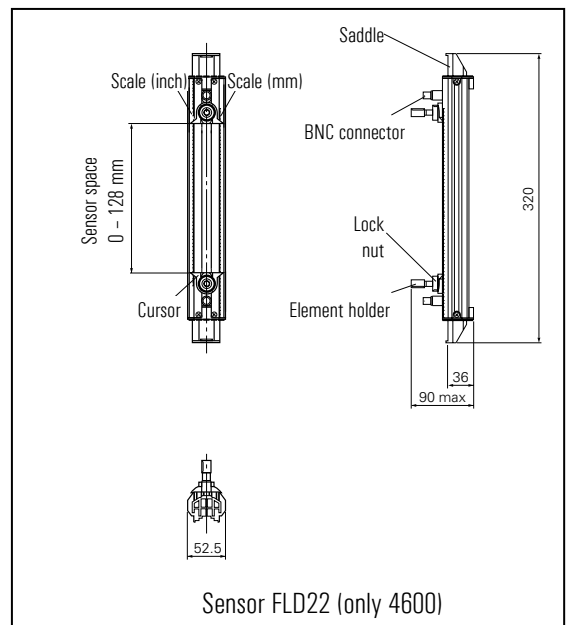
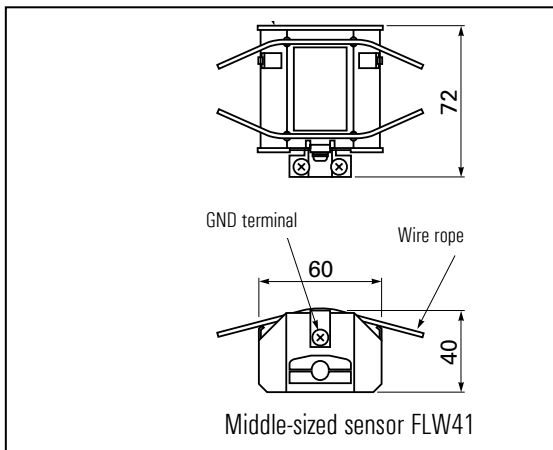
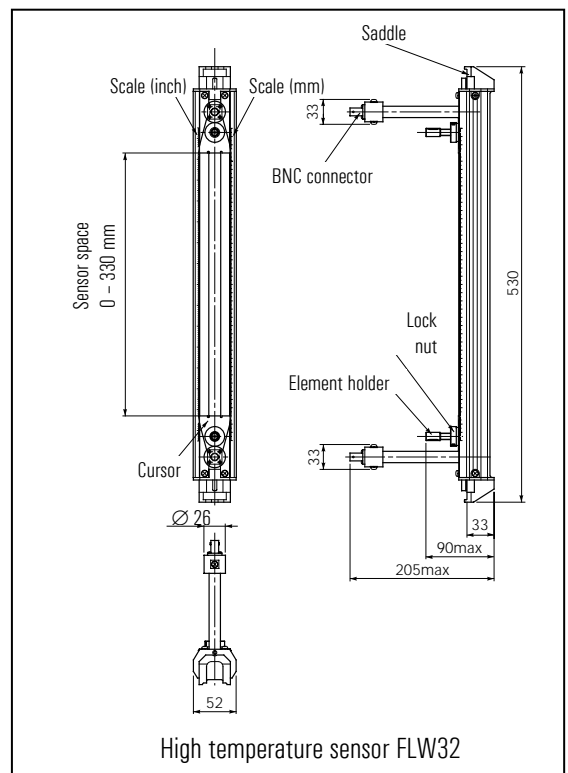
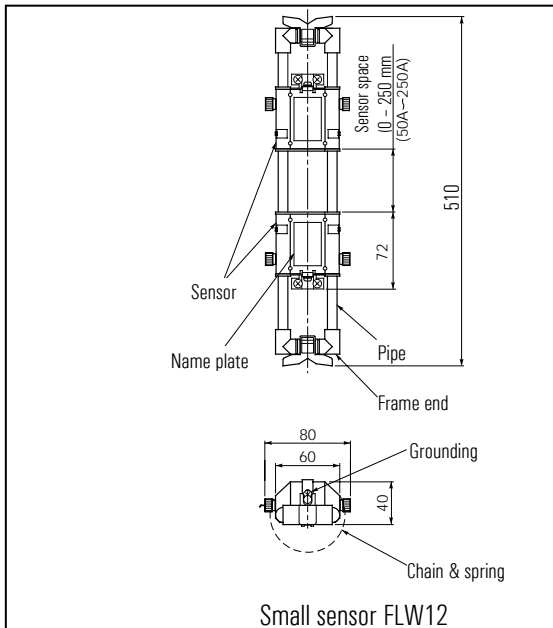
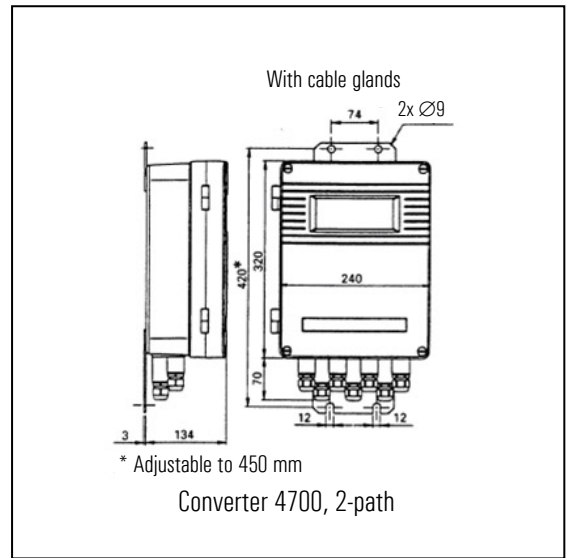
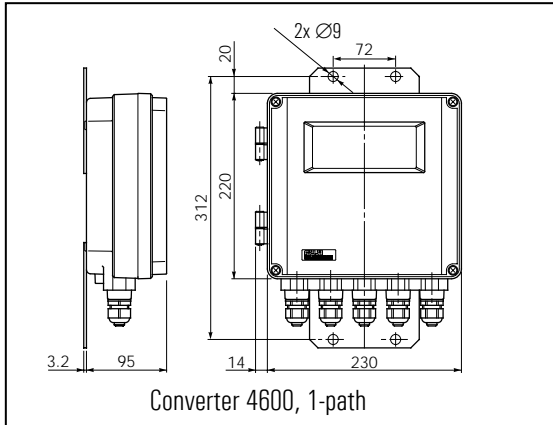

Sensor mounting

The following methods are available:

- 1.) Prefer the V-method, because the installation is the easiest.
- 2.) Z-method is used if the medium is loaded with a high portion of dirt or air/gas.
- 3.) The 2-path method (only for model 4700) is used if you expect changes in the flow profile during the measurement (for example too short straight inlet).
- 4.) 2-path method for measuring on 2 different pipes.

Single path system (V method)

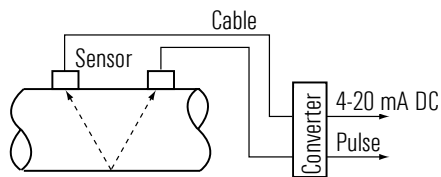

2-path system (V method)

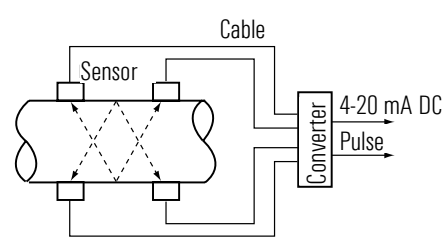

1-path system (Z method)

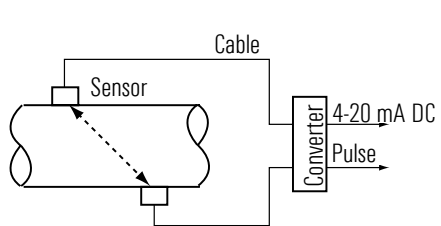

2-path system (Z method)

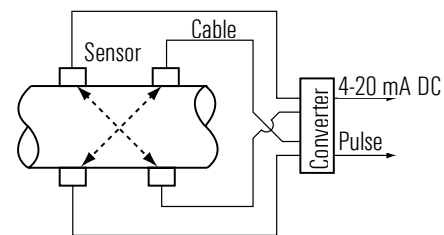

2-path system MoniSonic 4700 (different sensor types and methods)

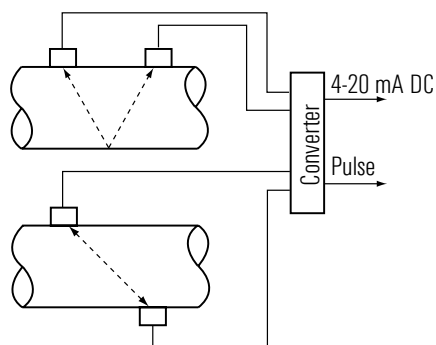

The complete measuring system consists of a converter (4600 or 4700), 1 or 2 pairs of ultrasonic sensors, sensor brackets and connection cables from the converter to the sensors.

Suitable ultrasonic penetrable pipe materials are carbon steel, stainless steel, cast iron, PVC, fiber reinforced plastics, asbestos, copper, brass, aluminium, acrylic, etc. Pipe liners can be made of rubber, cement, epoxy or bitumastic .

The analog and digital outputs are free scaleable. Possible assignment of the digital outputs can be a remote totalizer, flow direction, exceeding of measuring range, storage error and receiving signal error.